

DYSFUNCTION OF FUNCTIONAL DRINKING:
VOICES OF JAPANESE ALCOHOLICS' WIVES

By

KEIKO KATO

A dissertation submitted in partial fulfillment of
The requirements for the degree of

DOCTOR OF PHILOSOPHY IN ANTHROPOLOGY

WASHINGTON STATE UNIVERSITY
Department of Anthropology

December 2004

©Copyright by KEIKO KATO, 2004
All Rights Reserved

To the Faculty of Washington State University:

The members of the Committee appointed to examine the dissertation of KEIKO KATO find it satisfactory and recommend that it be accepted.

Chair

ACKNOWLEDGEMENTS

The completion of this thesis would have been impossible without the help of many people. First of all, I would like to thank the members of my doctoral committee who assisted me throughout my graduate program. I would especially like to thank my committee chair, Linda Stone. Her immense help was crucial to enabling me to put the necktie–alcoholism phenomenon into perspective. Her thoughts on gender and feminism are also an invaluable asset I gained during my graduate years; they are now well reflected in my dissertation, especially in the interviews. I would like to thank Raymond A. Jussaume, Jr. who pointed out the importance of this research topic and suggested focusing on the “dysfunctional” part of some Japanese unique customs that are generally perceived as “functional.” His suggestion to use a materialist approach to understand this phenomenon was also helpful. I am grateful to John H. Bodley, an inspiring anthropologist, who suggested the wonderful title “Dysfunction of Functional Drinking” to me. He was also very helpful for improving the draft of this dissertation. I also want to thank my friends at Washington State University who offered me crucial help especially during the last two months of my stay in Pullman: Fumiyasu Arakawa, Annette Bedner, LeAnn Couch, Nicholas Cerruti, Andrew Duff, Kathy-Lee Galvin, David Johnson, Diane King, Mary Lutz, Nancy McKee, Courtney Mehann, Elizabeth Siler, and Jim Williamson. I am indebted to all the anonymous interviewees who participated and opened up their personal lives in my research. Without these people, this study would not have been possible. I would like to thank the “Thomas S. Foley Institute for Public Policy and Public Service” for their support through a Graduate Fellowship and the Department of Anthropology who supported me through an International Scholarship. I am very grateful to my parents, especially my father, who taught me

the importance of education and constantly encouraged me not to give up, especially when I was going through difficulties. Last but not least, I am forever indebted to my husband, Michael Feise, for reviewing my writing, giving me many useful suggestions and tremendous emotional support.

**DYSFUNCTION OF FUNCTIONAL DRINKING:
VOICES OF JAPANESE ALCOHOLICS' WIVES**

ABSTRACT

by Keiko Kato, Ph.D.
Washington State University
December 2004

Chair: Linda S. Stone

In Japan, there are at least 2.4 million heavy drinkers [mostly male], only 1% (23,800) of whom receive proper medical treatment for alcohol dependence syndrome. Although many of these drinkers suffer from alcohol related symptoms, such as liver disorder, diabetes, and high blood pressure, they are often not labeled as “alcoholics [*aruchu*]” due to their respectable demeanor (clean, have decent/respectable job, hard working) and the Japanese permissive drinking culture where alcohol serves the functions of stress relief and strengthening human relations. In addition to these cultural aspects, the obstacle to early intervention for these alcoholics is the societal consensus that these people are “harmless” or “non-problematic.” Is this consensus, however, really correct? This study investigates the worldview of the wives surrounding alcoholics in Japan. By focusing on wives of alcoholics, and on their life histories, especially during the period from their wedding until their husbands’ alcohol problem was diagnosed, the study explores the hidden lives of these people which are currently considered to be free of problems by society. The study provides increased understanding of the causes of the husbands’ drinking and ideas for improving the current situation from their wives’ perspective. By using a feminist materialist framework, it also analyzes the reasons for the necktie-alcoholism phenomenon being unrecognized on a societal level. There are various cultural dimensions—the

androcentric/profit-oriented Japanese drinking culture and other cultural factors whose relation to drinking is not apparent at first glance (e.g. kinship and gender related cultural practices)—intertwined that contribute to the phenomenon where men drink excessively and wives tolerate such husbands. This study enumerates these cultural elements and discusses their problematic aspects. Based on the understandings that these dysfunctions are generated by the profit-oriented-system, the study posits that the real cause of necktie-alcoholism lies in the system. Based on the findings, it also concludes that the current Japanese criteria of problem drinker (alcoholic) are too lenient for male drinkers and overlook the problems caused from this permissiveness which can harm “the others,” such as the drinkers’ wives.

TABLE OF CONTENTS

ACKNOWLEDGEMENTS	III
ABSTRACT.....	V
CHAPTER 1: INTRODUCTION.....	1
Research Question	6
Methods	7
Recruiting the interviewees	7
Interview procedure.....	8
1. <i>Perspective on the husband’s drinking</i>	8
2. <i>How wives coped with the problem</i>	9
3. <i>Means of improvement</i>	10
Review of the interview report by the interviewee	11
Reviewing the Method	11
CHAPTER 2. THEORETICAL ORIENTATION	13
Feminist Anthropology.....	13
Materialist Approach: Economic Interest and Unequal Practices	14
Agony of Alcoholics: Kinship, Gender and Mode of Production	17
Analyzing the Drinking Culture from a Materialist Perspective.....	20
Women’s Lives and Necktie-Alcoholism	22
“Japanese Permissive Drinking Culture”; An Androcentric and Capitalist-Centered Ideology	23
The Study’s Contribution	26
Biases in the Study	27

CHAPTER 3. THE INTERVIEWS30

<i>Case 1. Hard working wife and the mother-in-law and sister-in-law problems</i>	31
<i>Case 2. (The reason of my abstinence is that) I don't want to make my wife cry anymore.</i>	52
<i>Case 3. A husband who "hates" medical institutions</i>	68
<i>Case 4. This is my fate. It is predestined from my previous life</i>	89
<i>Case 5. Triangular relations between husband, son and me (wife)</i>	109
<i>Case 6. Life has gone through the bottom several times</i>	129
<i>Case 7. The problem of kankeisei [relationship]; inferiority stemmed from the feeling 'I am being fed.'</i> 158	
<i>Case 8. I want to live at least one year longer than my ex-husband</i>	185
<i>Case 9. Since I became aware of his alcohol dependence problem, my life became a lot easier.</i>	200
<i>Case 10. Husband's amae and gender within the household</i>	219
<i>Case 11. When he died, all the bad memories disappeared completely. Right now, I only remember good things.</i> <i>It is rather hard for me to remember bad things about him</i>	252
<i>Case 12. Family Environment Peculiar to the hardworking and successful husband</i>	272
<i>Case 13. Many successful abstainers' wives also participate in Danshukai (Japanese self-help group) meeting.</i>	290
<i>Case 14. Wives have to take action from their side, too. It's their life. They are supposed to be responsible for their own lives. Suffering from anxiety caused by the possible doomed future alone is not good at all.</i>	313
<i>Case 15. Even if he is such a bad husband, I still want to live with him again.</i>	333
<i>Case 16. Today is the third week since he entered hospital</i>	353
<i>Case 17. I asked the doctor to tell my husband that his disease is very serious.</i>	385
<i>Case 18. I do not think that there is especially a [drinking] problem in my husband. But that might just be because I am good at adjusting to him. You see...I am ki-ga-yowai [≈unconfident and timid] person.</i>	403
<i>Case 19. My current husband is a quiet person. Since he becomes talkative when he drinks, I drank together with him to communicate with one another. (Wife: abstaining, husband: drinking)</i>	418
<i>Case 20. Only Tokiko - forever</i>	433

CHAPTER 4. DATA ANALYSIS	464
Grounded Theory Analysis.....	464
<i>Coding Themes</i>	<i>466</i>
<i>Code selection and feminist anthropology.....</i>	<i>467</i>
<i>Strength of ethnographical approach</i>	<i>469</i>
<i>Strength of ethnographical approach: Kinship and Gender Related Cultural Practices</i>	<i>473</i>
<i>Conceptual models through coded themes</i>	<i>474</i>
<i>Causes of Necktie-Alcoholism Phenomenon from Feminist Materialist Perspective</i>	<i>475</i>
<i>The Model—Appendix 3</i>	<i>476</i>
<i>Modified Model—Table 2.....</i>	<i>477</i>
Dysfunction of Functional Cultures: Cultural Factors that Contribute to the Phenomenon of Wives Tolerating Husband’s Excessive Drinking.....	489
1) <i>Inshubunka [Japanese Drinking Culture].....</i>	<i>489</i>
2) <i>Kinship and Gender.....</i>	<i>500</i>
3) <i>Other.....</i>	<i>509</i>
Dysfunctions of Functional Cultures: Cultural Factors that Contribute to Men’s Excessive Drinking.....	509
1) <i>Inshubunka (Japanese Drinking Culture)</i>	<i>509</i>
2) <i>Kinship and Gender.....</i>	<i>510</i>
Factors Characteristic of Alcoholic Families Worsen the Situation	518
Inadequate Public Support which Worsens the Situation.....	523
Types of Problems.....	527
Analysis Conclusion.....	533
CHAPTER 5. CONCLUSION.....	534
REFERENCES.....	539
APPENDIX 1: KURIHAMA ALCOHOLISM SCREENING TEST	546

APPENDIX 2: QUESTIONNAIRE	547
APPENDIX 3: DYSFUNCTIONAL OF FUNCTIONAL DRINKING (MATRIX)...	550
APPENDIX 4.....	552
GLOSSARY.....	554

LIST OF TABLES

Table 1: Five Periods of Enduring for Wives	471
Table 2: Causes of Necktie-Alcoholism Phenomenon	478
Table 3: Wives' Wishes for Solving the Problem	524

CHAPTER 1: INTRODUCTION

This dissertation points out the existence of hidden alcoholics (necktie-alcoholics) in Japan and questions the criteria of “problem drinkers” in this permissive drinking culture. This is done by focusing on the perspectives of the wives of alcoholics. Here, the phrase “(overly) permissive drinking culture” is used in a general sense, but it also marks a category relevant to Japan, as confirmed by Shimizu (1990) who examined the Japanese drinking culture using Pittman’s (1967) international-typology of drinking cultures. Some commonly observed scenes in Japan reflect the permissive drinking culture: a middle-aged white-collar worker sleeping at the train station because his drinking led him to miss the last train to go home; drunks harassing other pedestrians near the drinking district; drunks vomiting, urinating, and singing loudly in residential areas in the middle of the night; white collar workers drinking as an extension of their work. Although it is not commonly known, an aspect of this permissive drinking culture is the existence of many Japanese (mostly men) who do not realize that their alcohol related disorder(s) (e.g. physical and psychological disorders such as liver disorder, diabetes, high blood pressure, depression) are actually related to their alcohol consumption and are symptoms of alcohol dependence syndrome.¹

In Japan, there are 2.4 million heavy drinkers, only one percent (23,800) of whom receives proper treatment for alcohol dependence syndrome² (Endo 1992; Maruyama 2002: 111).

¹ For an overview of Japanese alcohol related sociological problems (in English), see Hayashida 1998, Omoto 1994, Higuchi and Kono 1994)

² The terminology used in this paper follows Japanese medicine’s definitions which follows the World Health Organization (WHO)’s International Classification of Diseases -10 (ICD-10). “Alcohol dependence” is a type of dependence (a cluster of physiological, behavioral, and cognitive phenomena in which the use of a substance takes on a much higher priority for a given individual than other behaviors that once had higher value) caused by excessive consumption of alcoholic beverages. It is a medical concept that generates from observing the psychological and physiological state of an individual. “Alcohol abuse,” on the other hand, refers to the use of

Many of those who receive treatment are in the late stages of alcohol dependence from which it is extremely difficult to recover. For a few decades, specialists involved in Japanese alcohol related problems have been emphasizing the importance of early diagnosis of alcohol dependence especially by general practitioners (Higuchi and Kono 1994; Higuchi 1995; Ino and Endo 1994). The tragedy of Japanese internal medicine, however, is that these patients, who mostly consult internal medicine doctors, still do not receive proper treatment from these doctors for their alcohol dependence problems. For decades, not understanding the nature of alcoholism, general practitioners have been labeling heavily drinking patients with socially non-stigmatized diseases (e.g. liver disorder, diabetes mellitus, high blood pressure, gout, sleeping disorder) without paying much attention to the core problem that causes these symptoms (Endo 1992; Takagi et al. 1989; Takagi 1987, Higuchi and Kono 1994). Rather, these patients are dismissed, based on the doctors' belief that they are reasonable adults who will follow their doctor's advice. As the use of the word "necktie-alcoholics [*nekutai-aruchu*]" to address these patients indicates (J. Kato 1994), this problem occurs since many general practitioners are blinded by the patients' respectable demeanor and social status that do not agree with the stereotype of alcoholics (e.g. dirty, unemployed, violent, etc). Not only doctors but also people in general perceive these necktie-alcoholics as normal people: they are drinking within the realm of the Japanese drinking culture.

alcohol in a way that deviates from the social norm. The criteria of alcohol abuse vary depending on the society and the individual's value system. "Alcohol dependence syndrome" is a disease where the symptoms of progressive alcohol dependence are considered to require treatment by clinicians. For this both the conditions of (1) alcohol dependence and (2) alcohol abuse must be met. "Alcoholism" was once a medical term, however it became so ambiguously used, for instance as a stigma for abnormal drinkers, that the WHO renounced its use in the medical sense. This study follows this recommendation and uses "alcoholism/alcoholic" as a social label to stigmatize deviant drinkers (for further information see Saito and Shimada 1990).

In Japan, studies have long been reporting the prevalence of males who suffer from alcohol related disorders among the patients of general practitioners and in the workforce. J. Kato (1989), who investigated 4,271 adult patients in his clinic using the Kurihama Alcoholism Screening Test (KAST) and medical means for diagnosing alcohol dependence, reported that 12.5 % of the over 18 years old males (30.6% of males in the age group of 50-59) had alcohol dependence syndrome. By using alcoholism screening tests such as KAST and CAGE³, a significant portion of the male patients of general practitioners are reported to be alcoholics: 19% in Murakami's study (1988); 12-13% in Han and Kitamura's study (2001). Kawakami et al. (1992, 1993) investigated 1,098 adult male employees of a computer factory; using KAST, they classified 15% of these males as having alcohol related problems. By estimating the γ GTP level (gamma-glutamyl transferase: indicator of liver damage due to alcohol consumption), many male company workers were also reported to have alcohol related liver disorders: 34.2% of workers in Shima's studies (1991) and 21.9% of workers in a trading company in Hanarewa and Komoike's studies (1983).

When interpreting such findings, one must also keep in mind that the medical criteria (alcohol dependence syndrome) are strongly influenced by cultural ideas about problem drinkers (alcoholics), which vary from society to society. In Japan, because of its overly permissive drinking culture, the criteria for alcoholism used in the medical field are lenient compared to those used in the U.S.. Mitamura (1978, 1981) applied the American Michigan Alcoholism Screening Test (MAST) to 177 Japanese non-alcoholic males (a group from which people with alcohol dependence syndrome—by the Japanese definition—were intentionally excluded). They

³ A brief alcoholism screening test whose name is constructed from the first letters of the key words used in the questions: “cut down,” “annoyed,” “guilty” and “eye-opener.” (Mayfield et. al 1974).

found that people scored 4.3 points on average (Mitamura 1978). This suggests that many Japanese normal drinkers qualify as “suspected alcoholics” (4 points) or “indicated alcoholic” (5 points or more) according to the U.S. alcoholism screening test. Mitamura suggested that MAST would be applicable to the Japanese population *if* the cut off line that distinguishes non-alcoholics and alcoholics is raised to 10-11 points for “questionable alcoholics” and more than 12 points for “probable alcoholics.” In Shima’s study (1978), which investigated the numbers of alcoholics among Japanese executives (N=100) and general workers (N=100), 54% of executives and 45% of general workers fell in the category “alcoholics” according to the American Alcohol Addiction Test (ALCADD). By raising the cut-off line from 20 to 25 points, the study concluded that 17% of executives and 27% of general workers in Japan were alcoholics. The criteria of alcoholics in the Japanese Kurihama Alcoholism Screening Test (KAST) (Saito and Ikegami 1978), which is commonly used to detect alcohol dependence syndrome in Japan, were designed to detect exactly these leniently defined Japanese alcoholics which results in 2.2-2.4 million (10% of population) “heavy drinkers” in the nation (Nukata 1979, Saito and Ikegami 1978; Shakai-byouri-kenkyu-han 1977). The numbers given by the studies in the previous paragraph were based on these lenient Japanese criteria using KAST. There is thus a strong likelihood that much higher rates of alcoholics would result if stricter criteria of alcoholism were applied (K. Kato 2003).

Contrary to the general belief that these necktie-alcoholics are reasonable people who will abstain or reduce their drinking if necessary, the reality is that there are very few who actually do this. One of the symptoms of alcohol dependence is denial of one’s own alcohol problem. Doctors’ lenient diagnoses—“liver disorder,” “high-blood pressure,” “diabetes”—without strictly making the patients realize the seriousness of their actual disease is misleading;

in the best case it lets the patients attempt self-guided abstinence or moderate drinking which usually fails. Without proper guidance through treatment, these people are prone to continue drinking and worsen the situation. This is the case since alcohol dependence is a hard-to-cure disease; even people who recognize their problem and thus want to abstain mostly fail.

Under the influence of the permissive drinking culture and in concert with other Japanese cultural factors, there is a great possibility that people surrounding these alcoholics are being abused. In fact, in Japan, there is a tragic aspect to this situation (alcoholics interfering with their family's lives), tolerated and treated as if it were almost non-existent in society. But it is non-existent only because most victims do not report it. As supported by the data of this study, this happens because Japanese public services are of little use to family members of alcoholics. Moreover there are various cultural factors which discourage them from speaking up: the ethic of avoiding shame, a tolerant domestic violence culture, gender related issues, people's ignorance about alcoholism, etc. These factors not only worsen the situation on an individual's level, but also worsen it on a societal level since they lead the society to maintain the permissive drinking culture even though alcoholics' family members suffer.

This study investigates the worldview and life situations of women surrounding alcoholics. By focusing on wives of necktie-alcoholics, and on their life histories, especially during the period from their wedding until their husbands' alcohol problems were diagnosed, the study explores the hidden lives of these women—lives which are currently ignored or considered non-problematic by Japanese society. In cooperation with members of self-help groups, 30 in-depth interviews with wives of alcoholics were conducted. What kind of life did they live until their husband's alcohol problems were recognized⁴? This study provides increased understanding

⁴ I use the word “recognized” instead of “treated/cured” since some of these alcoholics are still in denial and not willing to undergo treatment for alcohol dependence syndrome.

of the cause of husbands' drinking as well as ideas for improving the current situation from their wives' perspectives. From a feminist anthropological perspective, this research also analyzes these wives' worldview (value system) and practices which are contributing to the current situation where many of them suffer but endure the problems. Finally, it also criticizes the relevancy of the criteria of alcoholism based on the current Japanese drinking culture, which ignores the views of those affected by necktie-alcoholism, especially the wives, the most common target of alcoholics' abuse.

Research Question

The current societal consensus regards necktie-alcoholics as “harmless,” as shown by the expression “*shizuka na aruchu* (quiet alcoholics)” used to characterize these people (Nada 1981). However, is this consensus really correct? Are necktie-alcoholics really problem-free? To answer this question, it is useful to explore the perspectives of alcoholics' wives, who are most likely to be affected by their husbands' drinking. This research was originally developed from a previous study which investigated the worldview of Japanese necktie-alcoholics (Kato 2000). Contrary to these white-collar alcoholics, who were unlikely to indicate negative influence of their drinking on others, wives of these alcoholics whom I encountered related stories of their long suffering under their abusive husbands, especially before their husbands' alcohol dependence syndrome was treated. Many questions emerged: “Did this happen only to women whom I happened to meet?”; “What characterizes the lives of the wives, whose husbands' alcohol related disorder is detected but often dismissed by general practitioners?; Are they also suffering as claimed by the wives I encountered?”; and “Are current methods of intervention for alcoholism appropriate? If not, what are the means to improve the situation?” In order to answer

these questions, basically three topics are explored in this study: (1) how did the wives perspectives towards their husbands' drinking change over time?; (2) how did wives cope with their husband's drinking problems (if they perceived problems)?; and (3) what kind of changes or public services did wives seek or desire while they were in the midst of their problems? The detailed questions of each of these topics, how those questions were addressed (procedure of the interview), and the significances of these questions are discussed below in the Methods section.

Methods

During the years 2003 and 2004, in-depth interviews with 30 excessive drinkers' wives⁵ were conducted in a city in the Tohoku region of Japan.

Recruiting the Interviewees

This study recruited women through a variety of methods: I set out fliers and posters⁶; met with women at a domestic violence self-help group; and announced my research at self help group meetings (these are independent, private, voluntary organizations in Japan that assist people with alcohol related problems and their family members). In addition, some women had just heard of my research and came to me independently asking to be interviewed. Most commonly, interviewees were contacted through the connections of self-help group members in which I participated regularly. In addition to asking wives to participate in this study, I also asked the participants at self-help groups (not necessarily interviewees themselves) to tell potentially interested acquaintances about this study. Each time, a letter describing the purpose

⁵ All thirty interviewees had no previous encounter with the interviewer.

⁶ These described my research project and asked for women interested in being interviewed to contact me.

of the research, topics of questions covered, promise of confidentiality, expected length of the interview, contact information etc. was provided. When a wife accepted to participate in an interview, an appointment was made at her convenience and an interview was conducted. The location of each interview was chosen by the interviewee. Most preferred the guest room in a building prepared for this occasion while some preferred their houses.

Interview Procedure

In principle, I asked the questions and led the conversation based on my prepared questionnaire for the interview [See Appendix 2: Questionnaire on page 547]; but if the interviewee preferred to relate her story, then her story had priority over the prepared questions. In fact, in most cases, the interviewee led the conversation and I only gave support to expand the stories. Because of this, not all questions were covered in all interviews and questions that were not listed were sometimes asked. This made the subsequent comparison and quantitative analysis difficult, which is one of the weak points of this research method. This flexible qualitative method, however, worked well to make the interviewees feel comfortable and let them open up and relate their personal lives which was the major purpose of the research—understanding the worldviews of alcoholics' wives. The following sections explain the interview procedure and give the detailed questions of the covered topics and their significance.

1. Perspective on the husband's drinking

Regardless of whether or not wives had problems with their heavily drinking husbands, the first part of the interview asked the interviewee how she viewed her husband's drinking. How did she used to view her husband's drinking compared to other men's way of drinking? Was her view influenced by her family background where family members drank or did not drink? Did

her perspective change over time? How did it change? When was the first time she encountered her husband's drinking problem? When did she start to think that her husband is an alcoholic? What experience made her think so? It was possible that the wife perceived no alcohol related problem in her husband's behavior, just as suggested by the *shizuka na aruchu* [quiet alcoholic] hypothesis. This result could be due to a genuine absence of problems, but it could also be due to a woman's denial of her problems as an alcoholic's wife, the Japanese ethic of avoiding shame, and/or defectiveness of the research method (e.g. my lack of skill in conducting interviews). When any of these were suspected, the interviews explored these possibilities as much as possible.

If the wife perceived that her husband had a drinking problem, the interview proceeded further and asked for other aspects of her husband's drinking. What did she think was the cause of her husbands' drinking? After the open-ended question about the cause of the husband's drinking, I also asked about the following possible causes based on the literature on Japanese alcoholism: a husband grew up in a problematic environment such as having alcoholics in the family; educational background; harsh work environment; responsibility for being the first son; bad relationship between wife and mother-in-law, etc.

2. How wives coped with the problem

The second stage of the interview explored the nature of the problems confronted by the wife and her attitude towards them. Sometimes alcohol related problems (e.g. fights between husband and wife) were connected with the permissive drinking cultures, such as, for men, the prevalent opportunities to drink. Sometimes they were tied to gender related cultural problems, for example, a patrilocal, patrilineal, and/or patriarchal kinship system that cause(s) mother-in-law problems, a burden on the first son, and/or the wife's sense of inferiority that prevented her

from speaking out about her personal problems. Sometimes alcohol problems were not culture-related, but rather are better explained through concepts and ideas from the field of alcohol studies, such as the common patterns observed among wives of alcoholics, or among children of alcoholics, etc. With the help of a feminist perspective and an understanding of Japanese culture and alcohol studies, the interviews explored the problematic situations and the wives' attitudes towards their problems. Since many questions were created instantly as the interview proceeded, it was always possible that I asked leading questions, dismissed important information expressed by wives, and did not cover other important aspects. This is another deficiency in the method of this study. This style of interview, however, is one of the most important ways in which cultural anthropology can contribute to the study of alcohol problems—by uncovering the variety of beliefs and (culture-bound) lifestyles which have a strong impact on alcoholics and their wives' concerns.

3. Means of improvement

Understanding the needs of wives who suffer from their husband's drinking provides clues for improving ways to counter alcohol related problems in Japan. By asking women to freely express their wishes, this study explored wives' problems with the current cultural and social system. For example, the study asked women what services they desired from public institutions (e.g. health service, shelter, doctors, social workers, counselors, and self-help groups) and from people close to them (e.g. parents, husband, children, friends, and relatives). The problems may not only lie in the public service system that is improvable, but also in the way people believe and behave (see for example "the Japanese vertical social structure" theorized by Nakane 1970) which is very difficult to change. In fact, many data presented in this dissertation are collections of wives' views on many conventional Japanese customs. The study therefore not

only suggests changes to the Japanese alcohol related culture but moreover significant changes to many aspects of Japanese culture, especially those related to the traditional *ie* [household] system and gender.

Review of the Interview Report by the Interviewee

After an interview was conducted it was summarized, and the summary edited to maintain the interviewee's anonymity. The report was subsequently revised by the interviewees. Although most were reluctant to read over their interview, many were cooperative once they started reading the report. They elaborated on points that were not clear or were misinterpreted in the report. Any changes for improved anonymity and accuracy suggested by the interviewees were incorporated.

Reviewing the Method

The method of using my connection to self-help group members worked well to recruit suitable interviewees as well as to make them comfortable and open up, which were the two major challenges in this research. This method overcame these obstacles by taking advantage of two factors. The first factor is the knowledge of the self-help group members about the nature of alcoholics and their wives who often refuse treatment until the last minute. Because they were aware of this pattern and its dangerous consequences, they were able to introduce to me women whom they thought may suffer from the alcohol problems of their husbands. Some of these women and their husbands did not receive proper treatment for their alcohol problems and were therefore of particular interest to this study.

The second factor is the already established strong relationship between the interviewees and the introducers. This helped to establish trust between the interviewee and myself which was crucial for successful interviews. This factor was well expressed in one of the interviewees' honest words:

“I wasn't sure if I should accept this request. I probably wouldn't do it if it hadn't been Mrs. Suzuki's (pseudonym) request. How much I revealed, however, depended on you. Even though this was Mrs. Suzuki's request, I wouldn't reveal anything if you weren't the right person.”

Most women showed some nervousness at the beginning, but as they learned that the interview was not so difficult, they started to open up. Some women brought evidence (e.g. letters, diaries, essays, notes written about their husband's medical history, magazine articles etc.) which furthered my understanding of their lives. The total interview time per person varied from 1 to 6 hours, with an average of 2 hours 28 minutes. In general, I felt that most, but not all, interviewees were supportive of this research and thus willing to take the risk of revealing their stories in order to improve the current situation. Several women cried while talking. They commonly said they never before had any opportunity to speak about their suppressed feelings and therefore appreciated the opportunity to release their stress. Although this may be *tatemaie* [keeping the harmony], it still provides evidence of their tough situation where opportunities to speak about their problems are very limited.

CHAPTER 2. THEORETICAL ORIENTATION

Feminist Anthropology

Feminist anthropology is a subfield of anthropology that focuses on understanding gender cross-culturally and that advocates gender equality. It was developed in the U.S. through the feminist movement, beginning in the 1960s. The field gained momentum with the publication of the book *Women, Culture and Society*, by Michelle Zimbalist Rosaldo and Louise Lamphere in 1974. The book addressed the pervasive “male bias” in the discipline of anthropology as well as the importance of obtaining a cross-cultural understanding of gender. This book sought to combat the influential idea that female subordination to male is rooted in human nature, an idea that had been used to explain Western gender constructions and practices that assigned women as the secondary gender. While the book took the position that female subordination was cross-culturally universal, biological sex differences were rejected as the reasons for this cross-cultural phenomenon. A few anthropologists (for example Eleanor Leacock and Nancy Bonvillain) later claimed that some hunter-gatherer societies were gender equal and that gender inequality came about through contact with Western colonialism and the related changes made in the hunter-gather economic mode of production. Other researchers pointed out that "female subordination" cannot be defined cross-culturally in a way that is free of cultural biases (Stone 2000). In many cases what outsiders might regard as subjugation (e.g. veiling of women) can be internally or emically regarded as proper and supportive of women's own interests by the women themselves.

Feminist anthropology has grown and expanded considerably since the 1970s. Gender inequality is now approached through a broader framework that includes inequalities of race, class and ethnicity. These days more attention is given to the diversity of perspectives on gender

within a society and to the specific historical contexts in which gender has been constructed. Gender is also seen as less of a static cultural construction and more as a process, a negotiation and renegotiation, in everyday life (Lamphere, Ragone and Zavella 1997). Feminist anthropology, now studied by not only female but also male scholars, involves a variety of topics such as cross-cultural understandings of sex differences, power and systems of oppression, the history of various types of gender inequalities, and the impact and implications of modern reproductive technology on human lives.

What distinguishes feminist anthropology from other disciplines may be that, in addition to the interest in various issues of inequality, it often also takes a political stance. It is important to note that feminist anthropology is thus biased and sometimes political by frequently leaning towards the side of the oppressed ones, namely women. It is, however, also important to note that most social research is also biased in some respect, and not addressing one's bias can sometimes come at great cost. For this reason I address my own bias and political stance in this study. [See Biases of the Studies on page 27.]

Materialist Approach: Economic Interest and Unequal Practices

Among the various approaches existing within feminist anthropology, I use materialism to frame my research. This approach posits that the material conditions of social life (techno-environmental factors and the economic mode of production) determine the way people think and behave (Harris 1974). Materialists have presumed that “a society's economic base, or infrastructure, determined its superstructure—the legal, political, social, and cultural institutions that developed to ensure the continuation of the economic status quo. They also [see] these institutions as corresponding, in turn, to particular forms of social consciousness, determining the

very way people thought about the world and themselves.” (Marcia-Lee 2000: 48) People, who are positively or negatively affected by dominant cultural beliefs and values, may not be aware of how their perception and behavior promotes the continuation of the socioeconomic status quo. However, when the oppressed people realize how much the dominant sociocultural perceptions work advantageously only for the elite class (or capitalist class), they often can no longer simply accept their discontent and continue their suffering. In Marxist terms, when oppressed people realize how they have been objective allies in their own oppression, they abandon their former “false consciousness” and become advocates for radical change.

There are countless materialist (or Marxist) feminist anthropological accounts of how certain culturally specific practices benefit and/or exploit certain groups and how dominant ideologies are used as an effective means to justify these practices and manipulate those who are negatively affected by it (Harris 1974 and 1985, Stone and James 2001, Allison 2001). With some practices it is very obvious to see the advantages they bring to certain groups. For example, in Japan, highly educated men often obtain tenure track positions with various benefits immediately after graduation, while others, especially women, can only secure temporary clerical positions. Women are expected to quit work upon marriage or the birth of the first child and resume working as temporary workers when the children are grown up. In Japan, there are various ideological justifications to support this practice and many people actually believe in these justifications, such as “It is best for the child if the mother accompanies it while growing up”, “Women’s happiness is in marriage which is about finding a husband and raising children,” “Home-made food is the source of the healthy mind of good-hearted child,” “Women are like a Christmas cake; they are most valuable until 24 and lose value after 25.” These ideologies are influential and are advantageous for Japanese companies who hire women for clerical jobs and

replace older female workers with younger women before these older female workers become costly for the company due to the regulated increase in salary which is proportional to the length of service.

In other cases, the way in which particular socio-economic arrangements privilege some groups and disadvantage others is more complex. For example, Goody (1976) showed how the development of plow agriculture brought about class stratification in Eurasia (as contrasted with the lack of class stratification in the African system of hoe agriculture). In Eurasia those at the top of the stratification were advantaged and were able to maintain this position over the generations by instituting the practice of class endogamy (or sometimes, limited hypergamy). Class endogamies marriages, which prevented wealth from seeping out and down to the lower social strata, was further promoted by the institution of dowry marriages, where family property bestowed on women at marriage was “matched” with what a groom would inherit. This whole system in turn promoted restrictions on female sexuality and a high value on female virginity at marriage. According to Goody, to keep wealth inside the upper classes, marriages had to be strictly controlled by families and to do this, the sexual behavior of women had to be strictly controlled as well.

Goody (1983) also showed how the Catholic Church contributed to enforce some of these practices through instituting marriage rules (e.g. a ban on cousin marriage, prohibiting priests to marry, the idea that (rich) widows should not remarry but should be under the care of the church) while obtaining tremendous profit from these rules (Goody 1983, Stone 2000). It is not the purpose of this dissertation to show how each gender discriminative practice relevant to this study came into being, but to show how the existing discriminative practices in Japan contribute to wives tolerating their abusive alcoholic husbands and/or contribute to alcoholics resorting to

drinking, and how these practices are working to ensure the continuation of the economic status quo.

Agony of Alcoholics: Kinship, Gender and Mode of Production

As shown in this dissertation, many personal problems of the interviewed women and their husbands are related to or rooted in the Japanese traditional *ie* [household] system—the kinship system. These problems include the stressful life associated with the role of the first son (heir) who has to take over family responsibilities; the expectations towards the heir's wife (e.g. she should take care of her parents-in-law); the expectations towards men in general (e.g. they should financially support their family, should not pursue their *amae*); and the expectations towards women in general (e.g. they should be gentle, obedient, support their husbands). In this dissertation, I argue that most of the kinship and gender related cultural practices listed in the analysis section and the real cause of necktie alcoholism ultimately lie in the profit-oriented Capitalist system.

The economic mode-of-production and the kinship-and-gender system are strongly associated with one another. In her book *Kinship and Gender*, Linda Stone (2000) discusses how gender roles are intertwined with the kinship system+ of a society. Based on the universal behavior of humans—reproduction—and the premise that “successful reproduction is a vital concern for any society,” Stone perceives gender as an extension of the kinship system⁷ which involves various rules applied to the members of the group for its survival and continuation. She

⁷ Kinship system: “The ways in which a society defines and uses relations of kinship. [...] Along with ideas about reproduction, this system encompasses the rights and obligations recognized between kin, or groups of kin, the categories into which kin are linguistically classified, and the rules, or norms, that specify modes of descent, patterns of residence, and forms of marriage.” (Stone 2000: 7)

also contends that the kinship system is subject to change due to the interplay of economic and cultural forces which in turn affect gender.⁸

In the context of industrialized societies, feminist materialism posits that capitalism benefits from a male workforce under pressure. Men should feel obligation and pressure to support their wives and children. That will force them to stay in line. Women are useful to capitalism as domestic supporters and maintainers of the workers (providing cooking, house, cleaning etc.), reproducers of the working class, and as sources of very cheap labor. In other words, the male public/female domestic ideology is advantageous for the capitalist class for it efficiently extracts male labor (Lindsey 1997).

I posit that Japanese people are caught in a system where the economic mode of production shifted from agriculture to industry. This induced a situation where people tried to continue to follow certain responsibilities imposed by an agriculture-based society, but at the same time tried to adapt to new responsibilities imposed by an industry-based economy. People, especially the first sons and their wives, had already been experiencing certain stresses and strains with the traditional kinship system; however they came to experience new problems due to the relatively rapid change of the society from agriculture to industry.

Many scholars are inclined to perceive the post-war Japanese family as transformed (from “*ie*” 9extended family; importance placed on the continuity of the household) to the “nuclear family” which is often associated with changes such as the “emancipation of women,” the “modern [nuclear] family,” or the “fall of the status of the elders” (Ochiai 1997). This is, however, not quite true. Ochiai challenges the validity of the general consensus that the *ie* system was destroyed and replaced by the nuclear family system in post-war Japan. She bases her

⁸ In chapter 7, Stone (2000) discusses the history of the Euro-American kinship and gender where various economic shifts contributed to its current form.

argument on the fact that although the absolute number of nuclear families increased, the number of co-resident parents (extended family) did not decline in post-war Japan. This shows that one of the critical traits of the traditional system—the “stem-family norm” (where continuation of the family is enacted through the inheritance by one man, often the oldest son)—has not diminished in contemporary Japan. This also suggests that the problems associated with the stem-family norm, such as a hostile relationship between the wife and her mother-in-law, the role of responsibility of the first son, the role of the daughter-in-law, the conflict over inheritance between eldest and the younger siblings⁹, etc. still remain in Japanese society. The change in mode of production also brought about a dilemma where many heirs want to pursue a career in the industrial sector yet follow the traditional role as the heir of the family at the same time. It also re-enforced the dichotomy between the domestic sphere (female) and the public sphere (male) where the capitalist elites benefit, as shown above.

The connection between mode of production and kinship/gender in Japan is important to understand the psychological problems of Japanese people, especially the first son [successor], the wife of the first son, or the children of the first son, since the “stem-family norm” affects their lives significantly and can cause grave problems for them. The understanding of gender in relation to kinship, and the forces that affect the kinship system in Japan may therefore provide clues for understanding where the real problem in necktie alcoholism lies, which in turn can contribute to the improvement of the situation.

⁹ Although the legal principle is “equal inheritance”, everyone is expected to “voluntarily” give up their portion of the inheritance in favor of the successor (first son). This created a new problem among some contemporary Japanese families where younger siblings claim their legitimate portion of the property while the successor disapproves, which often leads to severe conflict among the siblings.

Analyzing the Drinking Culture from a Materialist Perspective

One can also view various aspects of the Japanese drinking culture through a materialist approach. It is easy to see, for example, how positively the media portrays the image of alcohol in commercials or in television shows which are sponsored by alcohol companies. In the year 1999, there was a beer product called “*Beer-water*”¹⁰ which was an alcoholic beverage [beer], but the design of the beer can was very similar to that of popular Japanese sports-drinks. The commercial for this product showed young attractive females and males enjoying themselves at the beach and portrayed the product as a non-alcoholic-like and sports-drink-like product. It is obvious to whom such a product is targeted and it is clear how this commercial can affect the way consumers view *beer-water*. It is also instructive to look at what kinds of facts, based on alcohol-company-funded scientific studies, are used to perpetuate the pro-drinking culture. For example some such studies support the notion that “Moderate drinking is better for one’s health than not drinking at all” and “Red wine is good for one’s shape-up diet.” (I know a woman who is careful about her eating habits, but does not hesitate to drink red wine despite the fact that alcohol is actually high in calories.)

This dissertation, however, focuses on a different yet very important aspect of the Japanese permissive drinking culture, where drinking is used as a means to tame workers to become efficient in the public sphere. Japanese alcohol companies have certainly benefited from this practice and have made countless commercials where capable white-collar workers drink at bars while grumbling about their work, or enjoy the *banshaku* (drinking with evening meal) while viewing some beautiful scenery. As Shimizu, a sociologist, contended in his alcoholic social system theory (1990), drinking is the means to lubricate the functioning of the society by

¹⁰ A product of Asahi Brewery, Ltd.

strengthening social ties and releasing stress for many male workers. Without alcohol, he argues, “Japanese society would not be able to function as a system” and emotions such as rage, stress, and the violence that are now suppressed by the drinking practice would break out (Shimizu 1990: 8?). Here, suppressed emotions underlie the generally stressful life of Japanese male workers. Countless Japanese white collar workers’ constrained and stressful lifestyles have been documented since the country attained its global economical strength. Kimiko Kimoto’s (sociologist) award-winning book *Kazoku gender kigyoshakai: gender approach no mosaku* [Family, gender and enterprise] (1995), for example, shows how efficient the Toyota employment system is by rewarding the workers little yet just enough to make them work hard. Robert Hsu’s (1999) The MIT Encyclopedia of Japanese Economy has a short description of “working hours and stress.” This describes the constrained lifestyles of Japanese male workers where some die due to *karoushi* [death from overwork]. It shows how difficult it is to obtain reliable statistics that reflect the pressures male workers experience in Japan because these workers practice unofficial business (e.g. drinking with colleagues after work). It also shows how long working hours were legally reduced in Japan, due to the Western criticism: “Japanese overwork and under-consume, thereby contributing to Japan’s export surplus” [!] (p-489).

These examples help us understand the cultural context where Japanese men are work-oriented and do not have much means for genuinely releasing stress, such as through a hobby or by interacting with family members. My suggestion is that the Japanese permissive- drinking persists because drinking has the function of engaging male workers even more in the public sphere by: (1) strengthening ties between work-mates and (2) releasing stress caused by the capitalist system with minimal cost to the system. Drinking can work for releasing stress because alcohol—as a drug—provides the “anti-structural” experience, which is crucial for all human

beings (Turner 1992), immediately and without failure (Kato 2000). Intentional or not, the permissive drinking culture is advantageous for many Japanese institutions in the public sphere and it is an advantage for the state which, according to Marx and Engel's argument, is "the political mechanism that protects the interests of the elite class" (Mascia-Lee 2000: 51). Based on the idea that the economical structure of the society determines the very way people believe and behave, it is possible to argue that the ideologies that support the permissive drinking culture (See examples on page 489-499) work advantageously for the industrial sector of Japan. And these drinking practices, as a side effect, re-enforce the pre-existing dichotomy of the public sphere and the domestic sphere where men are uninvolved in the domestic sphere because they are off drinking with colleagues. In this system many men harm themselves by drinking too much and, of special concern in this dissertation, their wives also suffer from their husbands' alcohol related problems.

Women's Lives and Necktie-Alcoholism

In the necktie-alcoholism context, women's lives are exploited in two ways. First, they are exploited through the Japanese dichotomy of the public sphere (for males) and the domestic sphere (for females) (Rosaldo and Lamphere 1974), which has benefited capitalism by putting males under pressure in the workforce while females support this "selflessly." In this manner male labor can be efficiently extracted. As my data shows, this leads men to drink because, for example, they can not perform well in the public sphere; their wives are not the ideal dependable wives; they have to serve the role of an heir; and most important "they are not allowed to whine as a man. This public/domestic dichotomy also leads women, confined to the domestic sphere and so dependant on men, to support such husbands. The second mode of exploitation is through

the permissive drinking culture which has benefited capitalism as described earlier. It has worked well by emphasizing the benefits the drinking culture brings to the public sphere and de-emphasizing the costs it incurs in the domestic sphere in Japanese society. This is the reason why men drink with pride and women virtuously tolerate such husbands in Japan.

“Japanese Permissive Drinking Culture”; An Androcentric and Capitalist-Centered Ideology

It is important to analyze the implications of the Japanese permissive drinking culture which involves the necktie-alcoholism problem, from a feminist-materialist perspective. This section first argues that the permissive Japanese drinking culture is androcentric by showing how the ideology of the permissive drinking culture is constructed in Japan. Then it discusses how this drinking culture is moreover a capitalist ideology by showing how this ideology is advantageous for capitalism.

First we examine the androcentric Japanese permissive drinking culture using a straightforward feminist approach (pointing out male bias in a phenomenon). This is appropriate since necktie-alcoholism is a phenomenon where the problems become invisible when seen from the dominant cultural framework— “*Nihon-no-inshu-bunka* (Japanese drinking culture)”—which does not reflect all Japanese people’s drinking culture but rather Japanese male drinkers’ drinking culture. The first tragedy for women affected by the permissive Japanese drinking culture is that the professional specialists in Japan, who interpret alcohol related behaviours and recommend changes (e.g. publish books or determine public policy), are not aware of the gender bias in their interpretations. Here, I will call their ideas the androcentric “Japanese drinking culture.” The androcentric “Japanese drinking culture” emphasizes the functionality of drinking

(e.g. drinking facilitates human relationships, drinking releases stress) which is important for many men and therefore can be used to justify their drinking. This drinking culture, at the same time, has the tendency to de-emphasize the damage caused by this drinking (often to “the others”) or sometimes even consider these damages as a part of the functional drinking system.

This male biased “Japanese functional drinking culture” was created through a similar process to the one which led the functionalists (mostly males) in anthropology to interpret cultures as functional. Evans Prichard (1951), for example, attributed the harmonious functioning and maintenance of Nuer society to the subordinate role of women who must not challenge their husbands. Although the interpreters and the creators of “Japanese drinking culture” were not cultural anthropologists but rather Japanese intellectuals, many of them made the same mistake as functional anthropologists of that time: they interpreted Japanese drinking culture without being aware of their own bias and its influence on their interpretations. Feminist anthropologists in the 1970s argued that the functionalists’ male-biased interpretations were due to the male anthropologists’ interpretations of men’s culture in the field (Mascia-Lee 2000, Bonvillain 2001). A parallel argument can be made for the reasons for “Japanese drinking culture” being male-biased: Japanese intellectuals are mostly males who themselves live and practice the drinking culture they describe and interpret their own male drinking culture as “the Japanese functional drinking culture.”

Androcentric culture in Japan is not limited to “Japanese drinking culture”; it is a general tendency observed in many aspects of Japanese culture. Yoshio Sugimoto, a social anthropologist, in his article *Making sense of Nihonjinron* (1999) argued that many publications in the genre of *Nihonjinron* [Books written about Japan or Japaneseness], which are supposed to represent Japanese culture, are “extracted from the cultural features of the male elite sector of

Japanese society at the exclusion of those of the numerical majority that occupy the lower strata of the society”(92). This happens because of what Sugimoto calls the “intellectual incest” or “mutual confirmation game” among writers, editors and readers of *Nihonjinron* who share a similar socioeconomic background (e.g. relatively high education, high income and prestigious jobs) and rarely step outside the intellectual milieu that shapes their world view. This suggests that the androcentric “Japanese drinking culture” is part of the larger androcentric “Japanese culture.”¹¹

The second tragedy for women affected by the permissive Japanese drinking culture is that these intellectual or *Nihonjinron* people, who perpetuate their ideas of Japanese society, are also not aware of their role in the society as the perpetuators of the ideology advantageous to the capitalist system. As Sugimoto pointed out, *Nihonjinron* writers have relatively high education, high income and have prestigious jobs. These people have the privilege to visit other countries as part of their business and express ideas that may help Japanese understand Japanese culture. It is important to note that these people are trying to achieve so fully in the public sphere that their identities correspond well with the interests of the capitalist system. This happens because capitalism rewards and provides pleasure for workers who play the capitalism game (e.g. work hard) and people who often do well adjust themselves in ways that are advantageous to the system.

To accurately understand the Japanese drinking culture, one must therefore understand the exclusive and profit-oriented nature of the current Japanese drinking culture and not ignore the perspective of “the others (non male-white-collar workers),” and moreover become aware of those who are exploited by the profit-oriented system. It is important to view the problem from a

¹¹ As was the case in footnote 1, androcentric Japanese culture will be written as “Japanese culture” (with quotes) which is distinguished from the general Japanese culture which includes

feminist perspective, because drinking is a behavior that not only affects the drinker himself but also others, especially wives, sometimes more than the drinker himself. Ignoring the perspectives of the others means ignoring the negative side of drinking (alcohol related problems) which is an important aspect of any drinking culture. Just as Marshall and Marshall (1990) examined the drinking culture of the Truk from a female perspective which differed significantly from that of males, it is necessary to investigate Japanese drinking culture from the perspective of non-drinkers' (non male-white-collar workers). Viewing the problem from a feminist-materialist perspective is also important, since male alcoholics are not only the legitimate group who should be blamed for this problem but also the capitalist system which created this phenomenon. I must emphasize that the problem is not only a problem of alcoholics and people surrounding them; it is also a problem for many other Japanese who work hard and drink to feel pleasure as part of their daily practice, which is an indicator of how exploited many Japanese people's lives are.

The Study's Contribution

This dissertation focuses on women—the wives of necktie-alcoholics. There have been innumerable materialist accounts of how and in what concrete ways capitalist systems negatively impact women. Few, if any, of these accounts, however, have revealed how this oppression is actually experienced by women themselves. This dissertation, by contrast, takes us inside the worlds of these women. It gives voice to these women, showing us how they perceive their own situation, how they see the Japanese drinking culture, and how they have struggled to cope with necktie-alcoholism in Japan. As a result, this dissertation unveils a new feminist view of Japanese culture in general and the problem of Japanese necktie-alcoholism in particular. The

“the others”: Japanese culture (without quotes).

major contribution of this dissertation to materialist/feminist anthropology is that it provides and inside (emic) view of a systematic oppression of women.

Biases in the Study

As described earlier in this chapter, it is important to address ones own bias in the methodology and the political stance of a study. For various reasons, this study has inherent biases.

Firstly, the case studies contain a certain bias. Because the purpose of this study was to uncover the potentially hidden victims behind the permissive drinking culture, my questions during the interviews were directed towards exploring the problems instead of the functional aspects of drinking. In addition, certain types of problems were addressed more than others. Since my interest lies in problems surrounding women in general, I caught cues of such problems and then expanded the conversations in certain directions, which may have led to some representation of the interviewees' lives. If my interests had been in psychology or in business, for example, I would probably have caught different cues from the interviewees' narratives and expanded the interviews in different ways. However, my understanding of many issues related to gender—such as the definition and problems regarding domestic violence (Sorifu 2000, Yoshihama 1999, Kozu 1999), women's status in the work place ("A Letter from Japanese women" Circle ed. 1994), criticisms regarding the nature of male and female (Stone 2000), problems with Japanese masculinity (Saito 1989, 1995, 1995, 2003), and problems of financially dependant women (Stone and McKee 1998) to name a few—also contributed to the effective

communication between myself and the interviewees. This made me sensitive to issues that otherwise would have gone unnoticed¹².

Secondly, among the thirty interviews conducted, only twenty interviews are presented here. I selected the 20 interviews over the other 10 largely based on my intention to show a variety of problems and yet bring important awareness to the problems and to maintain an acceptable size of this dissertation. All interviews had relevant points to be addressed and I regret I am not to be able to include them all. However, I intentionally excluded one case [Case 24] from this dissertation based on the fact that the conversation hardly addressed the alcohol related problems of the interviewee's husband. Despite the fact that this interviewee was the wife of an alcohol and drug addict, I was incapable of directing the interview to learn about her private life. There were four reports I would have preferred to include, they were about (1) a wife who may be considered a model of womanhood in Japan; (2) a typical dysfunctional family (e.g. the wife and husband grew up in dysfunctional families and formed a new dysfunctional family); (3) one wife's in-depth ideas on what she thinks about her husband; and (4) one woman who just had her husband hospitalized. These reports are not included because they are incomplete and need further investigation.

Thirdly, while I tried to be as objective as possible to depict the lives of alcoholics' wives, there are some occasions where I felt for the interviewees, became emotional and reacted emotionally [e.g. Case 6]. There were also occasions where I had to react as a reasonable person who supported the interviewees when they related their anger and sorrow at the time of the interview. I am aware that my behavior can influence the behavior of the interviewees and can therefore be considered problematic for a "scientific" method. However, I also want to mention

¹²E.g., what is the ultimate reason for not getting divorced from an abusive husband: financial problems, for the sake of the children, to avoid shame, not being able to get a decent full-time

that my emotional reaction contributed to the women revealing their personal stories which may have been impossible if I had followed the detached scientific method.

Finally, it is important to address the political stance of this study since, whether my intention was political or not, it could be used to change public policy. My personal stance was originally not political but rather purely an academic interest to uncover the mystical necktie-alcoholism phenomenon where it appears problematic in one way yet non-problematic in another way. But during the research, I became aware of certain groups of people being exploited in this society. My research challenges the dominant Japanese drinking culture and tries to create awareness of the problems which are currently treated as non-existent in Japanese society. This study also challenges various “scientific” studies which have contributed to the construction of the permissive drinking culture without the authors being aware of their own bias in the interpretation of their data (e.g. Shima and Mitamura’s studies which confirmed the current criteria of Japanese alcoholism without being aware of their bias. See page 27.) This study also advocates gender equality and wishes to illuminate various, currently hidden, costs to women because of the male-oriented/profit-oriented-capitalist permissive Japanese drinking culture.

job, lack of education, women expected to be subordinate.

CHAPTER 3. THE INTERVIEWS

In the following, I present my data in the form of 20 case studies of the wives of alcoholics. Here the material is presented in a way that stays close to the actual interviews. I present my questions to the interviewed women along with their answers in full. This is done to maximize the voices of these women and to provide, as far as possible, an understanding of the context in which their statements occurred. I often also present my own thoughts and reactions to their words. In these case studies, my informants' statements are enclosed in quotation marks. My own question or statements are preceded by a dash (-----).

Case 1. Hard working wife and the mother-in-law and sister-in-law problems

Name				Age		Occupation								
Ruriko Kodama				58		Part time worker at a supermarket								
Family						Husband's Occupation								
Nuclear <input type="checkbox"/> Extended <input checked="" type="checkbox"/>			# of members		5-6		Clerk at an electric appliance company (a victim of the company's restructuring, currently unemployed)							
Family members														
Taro		Husband		58		Strong sense of denial, Police involved accident,								
Ruriko		Wife		58										
Kazue		First daughter												
Tsugie		Second daughter												
Mitsuo		First son												
Total Interview Time						Wife Attending Self-help Group?				Husband Attending Self-help Group?				
First: 1 hour 50 minutes Second: 2 hour 30 minutes						<input checked="" type="checkbox"/> Yes <input type="checkbox"/> No				Yes <input type="checkbox"/> No <input checked="" type="checkbox"/>				
Wife's KAST concerning her husband's alcohol related behavior (See Appendix 1 on Page 546)														
1	2	3	4	5	6	7	8	9	10	11	12	13	14	Total
<input checked="" type="checkbox"/> 3.7	<input checked="" type="checkbox"/> 3.2	<input checked="" type="checkbox"/> 2.3	<input checked="" type="checkbox"/> 2.2	<input checked="" type="checkbox"/> 2.1	<input checked="" type="checkbox"/> 1.7	1.5	<input checked="" type="checkbox"/> 1.2	<input checked="" type="checkbox"/> 0.8	0.7	<input checked="" type="checkbox"/> 0.7	<input checked="" type="checkbox"/> 0.6	<input checked="" type="checkbox"/> 0.5	<input checked="" type="checkbox"/> 0.5	19
-1.1	-1.1	-0.8	-0.7	-0.7	-0.4	<input checked="" type="checkbox"/> -0.5	-0.2	-0.2	<input type="checkbox"/> 0	-0.1	-0.1	0	0	
?	?	?	?	?	?	?	?	?	?	?	?	?	?	
Analysis (See Analysis on Page 489)														
<input checked="" type="checkbox"/> A1	<input checked="" type="checkbox"/> A2	A3	A4	<input checked="" type="checkbox"/> A5	<input checked="" type="checkbox"/> A6	<input checked="" type="checkbox"/> A7	<input checked="" type="checkbox"/> B1	<input checked="" type="checkbox"/> B2	<input checked="" type="checkbox"/> B3	<input checked="" type="checkbox"/> B4	<input checked="" type="checkbox"/> B5	<input checked="" type="checkbox"/> B6	G1	
<input checked="" type="checkbox"/> C1	<input checked="" type="checkbox"/> C2	C3	C4	<input checked="" type="checkbox"/> C5	<input checked="" type="checkbox"/> C6	<input checked="" type="checkbox"/> C7	D1	<input checked="" type="checkbox"/> D2	<input checked="" type="checkbox"/> D3	D4	<input checked="" type="checkbox"/> D5	D6	<input checked="" type="checkbox"/> D7	D8
E1	<input checked="" type="checkbox"/> E2	E3	<input checked="" type="checkbox"/> E4				<input checked="" type="checkbox"/> F1	<input checked="" type="checkbox"/> H1		<input checked="" type="checkbox"/> H2	<input checked="" type="checkbox"/> H3	<input checked="" type="checkbox"/> H4	<input checked="" type="checkbox"/> H5	H6
Types of Problems (See Analysis on Page 489)														
<input checked="" type="checkbox"/> Verbal Abuse			<input checked="" type="checkbox"/> Physical Abuse			<input checked="" type="checkbox"/> Financial		<input checked="" type="checkbox"/> Psychological			<input checked="" type="checkbox"/> Shirinugui		Child-Related	
Note														

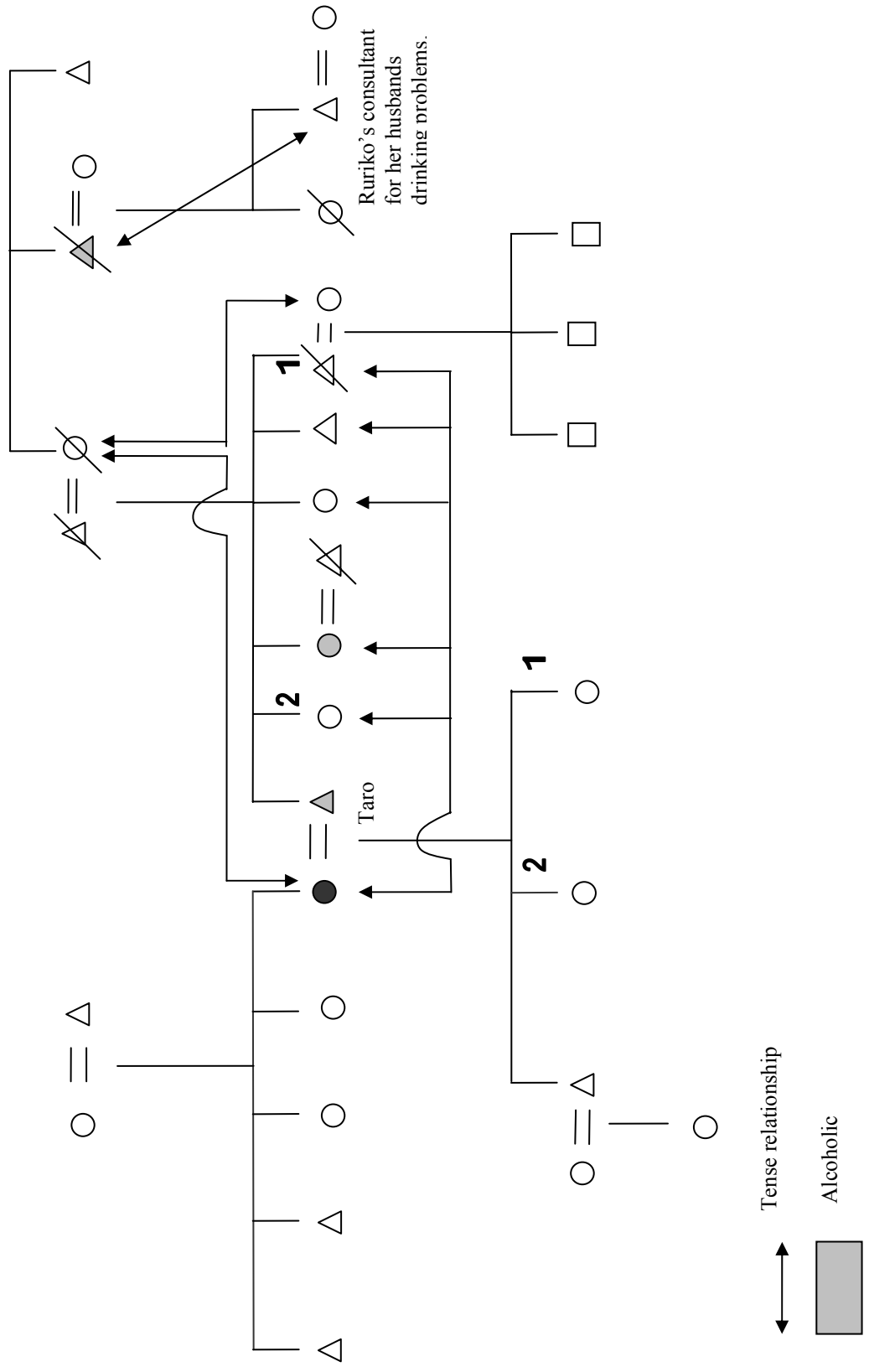

Ruriko Kodama

My impression of Ruriko Kodama was that of a hard-working and reliable person. She related her story energetically although it is as severe as that of other wives. However, because of her joking tone, our conversation was far from having a dark atmosphere. I was in a situation several times where I involuntarily laughed but the moment I did, I questioned to myself “Am I supposed to laugh here???”

Ruriko: “My husband [Taro] has a leaking problem. He drinks but can’t go to the bathroom because he is drunk so he leaks at the spot! Thinking about it now, he already had this problem when we got married. When the children were still little, we used to sleep together on a collection of futon mattresses placed next to each other in one room. When he peed in the bed, his futon became wet and cold, so he moved into his daughter’s futon. When this happened, in the middle of the night, my daughter screamed, ‘Father! You are wet! Don’t come to my place! Get out!’ Also, there was a time when he was doing *tanshinfunin* [business bachelor, see glossary on p-554] where no one took care of his toilet accidents. Because of this, whenever he came back home to meet us, he always brought the towels soaked with his urine as a souvenir. [I laughed involuntarily which changed into a wry smile afterwards.]”

Ruriko’s story was a continuation of such talk. Is it because she has been to a self-help group and therefore is used to talking amusingly in front of people? It is because she can’t talk about such a depressing story without making it into a joke? Or, it is possible that she is considerate about me who might portray her as a merely depressed victim which she doesn’t want? Even now, I don’t know why I was so entertained by her talk. Perhaps she herself was not aware that she was relating her serious story in such a joking tone either.

Caring children

Ruriko's participation in the self-help group started when her children, who could no longer bear their father's drinking problem, consulted the staff of the neighborhood's self-help group which was advertising itself on the web. After some consultations with the self-help group staff, the children advised Ruriko to participate in the self-help group, which she did. According to Ruriko, all of these children graduated from university, and she is proud of it. All of them also seem to be reliable people. Happily showing me the navy-blue fleece sweater she was wearing on that day, she told me, "This is a gift from my daughter last week. [Ruriko looked very happy.]"

The husband who refused to undergo medical treatment for alcoholism

Ruriko is currently in the midst of the problem. Her husband's denial is so strong that he refuses to undergo medical treatment for his alcohol problem even though the family members ask him to do so. According to Ruriko, every time when his workplace's mandatory health examination approaches, he abstains for several days which make his alcohol related physiological problem medically undetectable.

"[About his alcohol related physiological problem being undetected] Well that's not exactly true. He does get caught through the blood examination occasionally. But that doesn't stop him from drinking anyway. He even declared to me: 'I am *never ever* going to quit drinking.' While saying such a thing, he keeps on drinking every day, literally every day...."

As one might expect, Ruriko's husband is not connected to any self-help group yet. In contrast, Ruriko, who is not an alcoholic herself, never misses the local self-help group meetings which are held every week.

The husband who changes 180 degrees when drunk

Ruriko's husband is calm and quiet when he is sober. Ruriko even acknowledges this good (sober) character to some extent, too. The problem however is when he is not sober; her husband is a completely different man when drunk.

“My husband changes his character 180 degrees when he is drunk. When he drinks, he becomes like a snake. He becomes short-tempered and flies into a sudden rage. When he's drunk, I am afraid of him.”

-----Is there any violence?

“There isn't much physical violence. Well, there was some when we were young, though. To my son, to my daughter.... yeah, it happened occasionally.”

Although she answered in this manner when I asked particularly about the presence of violence in the house, I did notice the seriousness of violence in this house through various remarks expressed by Ruriko in the interview. It appeared to me that Ruriko's definition of physical violence is violent conduct which is also very harmful. The following was her comment right after she expressed that her husband is not so physically violent generally.

“[When my husband drinks] I usually escape immediately. Escape doesn’t mean running away from him, though. He was a marathon runner when he was young. He will easily catch me if I just run. I usually hide somewhere to escape from him. Sometimes my daughter advises me, ‘Mom, if dad starts drinking, just escape wherever you can. It can be at your friend’s house or at our neighbor’s house. I mean anywhere. You don’t have to be worry about our neighbors, they know our house’s problem anyway. You don’t need to stay outside alone on a cold winter day. Anyhow, just escape from him until he becomes sober.’”

According to Ruriko, her husband pounds tables or throws objects at her ‘in a way that they don’t actually hit her.’ He sometimes gets into a rage even though he is sober, too.

Husband’s drinking problem

-----Have you had any alcohol related problems that involved the police?

“Yes, all the time. Every time when he goes out to drink, I become nervous because I might receive a call again. When it comes to weekends, not only me but also my children are nervous, too. It’s very tiresome for me since I have to put myself to a half-sleep mode until he comes back home on such days [Ruriko makes an annoyed face.] This year, police-related accident happened about once per month. It happened in January, February,in March too,we didn’t have one in April, ...but it happened in May and June and ... He got caught in a traffic accident because he ignored a red light, by drunk driving, by sleeping on the sidewalk, by getting into a fight with someone... And every time when he gets into trouble, I am the one who receives the call... There was one time when he went into somebody else’s house when he was drunk, assuming that it was his house. We were lucky since the owner of the house was a nice person. I was told that they

thought my husband was a demented old man [Ruriko made a wry face.] Of course for this incident, too, I took a box of cake and went there to apologize for my husband's misconduct. I occasionally receive a call from a bar's *Mama* [Female bar manager, see glossary on page 556] who asks me to pick up my husband at their bar, too. Since I refuse these requests, they end up calling the police."

-----Your husband must be familiar with the police by now, isn't he? [I laugh. I am half-joking.]

"Among the policemen, there are some who are kind enough to even give him a ride home. When that happens, he shows appreciation to the policeman saying, 'Mr. Policeman, why not have a cup of tea before you go back to work?' [Ruriko made an annoyed face and I smiled wryly.] [Ruriko pauses.] These days, since I learned through the self-help group that taking care of an alcoholic's mess is the wrong thing to do, I try not to do these kinds of things anymore. I said to him, 'From now on, even if I receive calls, I am not going to take care of you, okay?' [Ruriko paused.] But...One day, it was about midnight, which is around the time my husband usually comes back. Our dog barked and the door bell rang, so I thought 'Oh, it's my husband again.' and simply ignored the bell. Some time has passed, but my husband didn't come into the house as I expected. So I went to the door where I saw someone standing behind the door. Contrary to my expectation, I saw a policeman standing there instead of my husband when I opened the door. And next to him was my husband sitting down on the floor drunk. The policeman said to me, 'Oh, I didn't know you were here.' It seems like the policeman brought my drunk husband home."

Ruriko kept talking.

“He has caused an accident while drunk and was taken by an ambulance. In the ambulance, he was saying something loud which didn’t make any sense. He was probably asking me to do something, but since he was drunk and couldn’t articulate, I couldn’t understand what he was trying to say. As a person who had to accompany him, I was very embarrassed.”

He made many dents in his car, too. According to Ruriko, her husband’s driver’s license was taken away because of his drunk driving.

“Right now, our car is at my parents’ place [so he will not drive]. It’s at my parents’ and not at the place of his brother who lives in our neighborhood, because if it is at his brother’s place, my husband will go there immediately and gets it back. These days, he is very willing to visit my parents’ place...but I think behind this exists his hidden intention to get the car back. [Ruriko nods several times and looks ponderingly.] He yells at me occasionally, ‘Hey! Get the car back! You are taking everything away from me!’ Since my parents’ family knows about our situation, they remind me frequently never ever to come and get the car back.”

Husband’s family’s drinking environment

All of Taro’s siblings like drinking. First, his mother’s brother was an alcoholic.

“He [husband’s mother’s brother] had drinking friends. In the old days when the restrictions on drunk-driving were not so strict, he drove back home after he drank with his friends. He changed his character 180 degrees, too. His son couldn’t stand his father’s drinking problem, and one day scolded his father, ‘Make a choice, father: alcohol or me! If you are going to chose alcohol, I am going to get out of this house!’ After this, the father stopped his drinking completely. Even

though there were many drinks sent to him as *oseibo* [year-end present] or *ochugen* [midyear present], he didn't try a drop of alcohol. [Ruriko pauses.] Taro, on the contrary, is hopeless... He drinks 365 days a year. He doesn't have a day of *kyukanbi* [resting day for liver, see glossary on p-556]. On his day off, he starts drinking in the morning....”

Ruriko's sister is an alcoholic, too.

“When Taro's sister goes out for drinking, I heard that her husband locks the house's door to not let her in afterwards. It seems like she is now fine, though. Her husband died and so she is very careful about her health right now.”

Ruriko says she herself drinks moderately, too.

“Sometimes, I drink, too. I drink about a glass of beer, I think. The way I drink is absolutely different from the way my husband drinks, though.”

Marriage

Ruriko and Taro's marriage was arranged.

-----Were you informed about his drinking habit at all before the marriage?

“It seems like he already had drinking problems before we got married. But through the go-between, I was informed that he neither drinks nor smokes. Gosh! He was such a liar! [Ruriko

laughs.] Of course my husband says the same thing back to me, too: ‘I was told that you were a good-tempered and quiet person!’ [I laugh.]”

Mother-in-law problem

Ruriko did not have a good relationship with her mother-in-law. While her mother-in-law was very caring to her own children, she was strict to Ruriko. For example, Ruriko’s family was operating a farm. Ruriko’s mother-in-law often gave many good quality vegetables and fruits to her own children (Ruriko’s husband’s siblings). At the same time, she insisted that Ruriko cooks with the left-overs, low quality vegetables and fruits, even though Ruriko and her husband were the people who actually worked hard to make these products. Ruriko was often upset about this. She asked herself, “Why? We are working hard. Why does all the good stuff go to Taro’s siblings and not us?”

“If my mother-in-law happened to have trouble with me, she made a fuss, ignored me, or sometimes talked bad of me to her children. In addition, she never admitted any fault or apologized. I still remember it was a cold winter day with only -6 degrees Celsius [23 degrees Fahrenheit]... To prevent the water pipe from freezing and cracking, we usually had to turn on the tap a little bit at night. Well, one day, my mother-in-law mistakenly opened the tap too much without taking the plug out and the whole room flooded. It was in the middle of the night when I noticed it and had to clean it up. It was extremely cold, but I had wiped the water up. My hands were terribly cold [Ruriko trembles as if cold.] What upsets me is that my mother-in-law, who knew that I was complaining and working on the floor for a long time, pretended not to notice anything. She stayed in her room. She neither helped me nor expressed any apology or

appreciation by saying ‘Thank you.’ or ‘I am sorry.’ afterwards. Not a single word about this matter.”

-----What was your husband’s attitude towards your problems with your mother-in-law?

“He was on his mother’s side. Since my mother-in-law is a glib talker, whenever the two argued over something, my husband usually lost and was coaxed to grant her request. In addition, my husband is very considerate to his blood relations, such as his mother and his siblings, however, not to his wife, to me. I am always treated as an outsider not only by my mother-in-law but also by my husband.”

In regard to Taro’s support of his mother, Ruriko related this story.

“I was thrown off a motorbike by my husband. It was when I was still young. One day, like usual, I was quite annoyed by my mother-in-law and so I wanted to vent my frustration. I therefore asked my husband to take me out to a place with a nice view. He took me to the nearby coast on his motorbike. At the viewpoint, I blurt out about my mother-in-law inadvertently to which he made an angry face. On our way back, while we were driving on an uneven gravel road, he purposely turned suddenly at the curve which made me fall from the motorbike. Since I wasn’t injured seriously, I didn’t go to the hospital. But I know that this was intended. After all, I walked back home alone without getting back onto his motorbike again.”

-----Are you saying that your husband did this purposefully because he was mad about your complaints about his mother?

“Yes, that is what I believe.”

Ruriko also said that she has been punched in the stomach by her husband for the same reason.

The most irritating problem for Ruriko

Because of the Taro’s consideration of his siblings, he has made various sacrifices for them. In terms of inheritance, Taro’s portion was relatively small despite the fact that he looked after his parents. Among his siblings, one person inherited more than him. In the Japanese system, where the oldest son usually takes care of his parents and inherits everything, this is remarkable.

“My husband cares about his siblings and does many things for them. But contrary to how much he cares for them, they don’t care much about him. This is the most irritating thing about my husband for me. I often say to him, ‘You are too softhearted and that’s why you always end up getting a bad deal.’ but he flatly rejects my point by saying, ‘I have the words in this matter! [≈You shut up!]’ In the worst case, he drinks and uses offensive language towards me, too.”

-----How are your relations with your husband’s siblings?

“Unfortunately, I have almost no connection with them. Because we went through some trouble regarding the inheritance, I don’t communicate with them that much. Because of this, I don’t...rather it’s better to say, I can’t consult about my husband’s drinking problems with them, either.”

The problematic mother-in-law

-----According to the Japanese common custom, it is the first son's family that should take care of the parents. Why does your family live with your parents-in-law despite the fact that Taro is a second son?

“Originally, my mother-in-law was living with her first son's family. But she was on bad terms with the eldest son's wife. When the eldest son died early, my mother-in-law refused to continue to live in that family. I heard that my mother-in-law said to the wife, ‘I will give you all his property, so please get out from this house.’ This happened before I married into this family. So, when I came into this house as a bride, many neighbors who knew about this commonly said to me, ‘You are a brave bride [I wouldn't do this if I were you].’”

Ruriko also related an experience when her mother-in-law was hospitalized.

“It was a horrible experience for me since my effort was not appreciated. I did many things such as take care of my mother-in-law's excrements [diarrhea] or dealing with her roommate with whom she had quarrel... but I once heard my mother-in-law talking about me with her relatives: ‘Next time I get hospitalized, I am going to ask professionals to take care of me.’ I became very upset and hurt when I heard this. She said this in front of me, in front of the person who took care of her the most among the entire family!”

The hospitalization was unfortunately prolonged for a while. When people started worrying, Ruriko's sister-in-law went to a *kitoushi* [shaman] for advice. The shaman told her that the location of the hospital wasn't good. They therefore moved Ruriko's mother-in-law to a different

hospital. In the next hospital Ruriko's mother-in-law was diagnosed with a different disease and a different medical treatment was performed. With this treatment she recovered from her disease.

Sister-in-law problem

In addition to her mother-in-law, Ruriko also had a bad relationship with her sister-in-law.¹³

"My sister-in-law was worse than my mother-in-law. She was only 1 year older than me, but she was a quite bossy person. Just because she graduated from 2 year college, she treated me as if I was stupid. By the way, I am a high school graduate. Anyway, she was a moody person.

Whenever she had a hard time at work, she vented her anger on me for no reason. Sometimes, she slammed the door *BANG*, like that, and left the room. [Ruriko seems to relive the experience and then made a troubled face.]"

Divorce

In such difficult human relations, Ruriko thought of running away from the house several times.

"I couldn't tolerate my life which was like a bed of nails. So I told my intention to divorce Taro to the go-between of our marriage. The go-between seemed to understand my situation, but he also told me, 'If you are going to divorce him, which you probably can, you will have to leave the child in his family's house.' When I was told so, I felt as if someone splashed water on me and so I woke up and felt the reality. Then, I thought about killing myself. But I couldn't."

According to Ruriko, she doesn't mind divorcing Taro now but would do so only if she had enough money to support herself.

“Only if I had about 20 million yen [\approx 181,818 U.S. dollars] though... If I was still in my forties...I probably would really divorce him. [Ruriko pauses.] My husband sometimes says to me, ‘You can go away any time!’ [Ruriko pauses again and then seems to change her mind.] But, no.... No, I am never going to divorce him.... I have done things my own way this far. If I divorce him right now, I feel like all my efforts will end in failure.”

-----Is there any other reason besides financial problems that prevent you from divorcing him?

“It's for the sake of appearance. Divorce at this age sounds shameful to me.”

Reasons for husband's excessive drinking

Ruriko thinks that the tense human relations within the Kodama family are the root of Taro's excessive drinking.

-----Do you think your bad relationship with your mother-in-law put your husband in a difficult position, which induced stress in him and consequently led to him drinking excessively?

“Yes, there is certainly that aspect.”

¹³ In Japan, as the phrase "*Kojutome wa hyakki* [Sister-in-law is like hundred ogres \approx If mother-in-law is an ogre, sister-in-law is like a hundred ogres]" indicates, a sister-in-law can be more

-----Can you think of something else that may be a cause of his drinking?

“Well, you are asking the reason besides him liking alcohol, right? [I nodded.] Hmm. [Ruriko pondered.] He already drank a lot when we got married, but when his mother died, his drinking increased. Even now, he occasionally drinks and talks about his mother. While saying something like ‘Poor mother.’ he feels pity for his mother.”

-----Could work related stress be the cause of his drinking?

“Yes. When his mother died, he caused an alcohol related accident and therefore had to quit his job. Afterwards, he was willing to work and found a job, but he got fired almost immediately since the company decreased the employees. He was cut off as part of the company’s restructuring process. Around that time, his drinking increased, too.”

According to Ruriko, her husband was an extremely serious man when he went to work.

“He was always thinking about work even while he was sleeping; he talked about his work in his sleep. He had some subordinates working under him, too.”

-----Anything else that could be a possible cause of his drinking?

troublesome for the wife than the mother-in-law.

“Some people told me that it may be due to some kind of *innen* problem [fate, problem in the spiritual world]. So I thought about *oharai* [rite to exorcise evil spirits]. But I was told that doing this will cost 1 million yen [\approx US\$ 9,091], so I decided against it.”

Children

-----Some experts say that children who were brought up in a family with alcoholics are vulnerable to becoming adult children [AC, see glossary on page 554]. Do you think your children are okay in this respect?

“My children were reading books about AC, but I don’t think they have problems that are considered serious. My first daughter, second daughter...third son.... No, I don’t think they have that kind of problem. Although my daughters tell me that they don’t want to get married. And my son says something like ‘I don’t want to be like my father.’ My son is married, but his wife doesn’t drink at all. I think she is a biologically incapable drinker. By the way, my daughter-in-law does not have the proper serving attitude or gentleness as a wife, but that’s okay. Many things changed for women since I was young... [We did not talk any further about Ruriko’s relationship with her daughter-in-law.]”

Husband who is *samishigariya* [a person who cannot stand loneliness, see glossary on page 556] with a lot of free time

According to Ruriko, now that Taro is retired and has few friends, he has much time, and he uses it to keep watch on Ruriko’s behavior.

“You see, he has a lot of free time since he is not working anymore. Because of this, he is watching my behavior all the time. Whenever I leave the house, he asks me, ‘Where are you going?’ or ‘When are you coming back?’ When I am talking on the phone with somebody, he is sometimes listening to our conversation secretly behind the door. Gosh, I wish he would make his own friends! But unfortunately it seems he can’t do that. [Ruriko paused.] When I come home late, maybe about 1 hour late, he is waiting for me furiously.”

Sometimes when Ruriko comes back home late from the self-help group meeting, Taro starts drinking and is waiting for her drunk.

Ruriko’s part-time work

Currently, Ruriko is the breadwinner of the house supporting her husband who had to retire. She is working part-time at a supermarket. Her job includes various tasks such as counting the money, arranging the wares on the shelves, etc. Because she is the most experienced employee at the shop, she is frequently asked to work overtime.

“Ohh, I am very busy. Extremely busy. But the current branch manager of the shop is an inconsiderate person. He is the most inconsiderate manager I have ever had since I started working here. Since he is a 40 year-old single man, he doesn’t understand the feelings of a woman like me who has to work at home and outside. When I am working overtime, which I don’t want to do, he pretends that he doesn’t notice my tough situation at all. I want to complain, but I can’t. I am old. I am concerned that if I complain, he might say something like, ‘Well, okay. Why don’t you quit then?’ I can’t do that. This is really tough. These days, one of my friends told me that the place where she is working is looking for a cleaner of the building and asked me if I

am interested. It was intriguing, but I refused. I am too old to do physical labor [Ruriko is 58 years old]. I don't think that at this stage of life I could learn new work either..."

Ruriko manages all the household expenses in this house. She is the one who keeps the bank book, too.

"If I let my husband do it (manage the money), our house will go bankrupt right away. [Ruriko says this in a determined tone.] I do give him money if it is necessary. I do show my resistance when he asks for money to buy his alcohol, though. In general, he gets most of the money he wants, though. [Ruriko paused.] Gosh I am really doing this much for him! Why doesn't he show any appreciation to me! It really makes me mad!"

Help from other people

Ruriko is currently still in the vortex of the problem. I asked her whether she has someone she could consult about her problem.

"These days, I have a female friend in the neighborhood who is having a similar problem. The conversation with her gives me enormous emotional support right now. Her husband is impulsive like Taro, so we have many things in common. Every day in the evening, we go walking together. I appreciate this opportunity very much."

Ruriko also mentions that her mother-in-law's brother's son's wife is a good consultant regarding Taro's drinking problem. Her husband once said to his father 'Make a choice, father: alcohol or me! If you are going to chose alcohol, I am going to get out of this house!' as described earlier in

this report. Her husband, too, helps Ruriko out, for instance by taking Taro to the hospital when he had to be hospitalized.

“...But my husband never says ‘Thank you’ or ‘I apologize for making you do all these for me.’ This problem was actually mentioned by my mother-in-law’s brother’s son when my husband got hospitalized and he helped us out.”

Self-help group

Ruriko also mentioned that her participation at the self-help group was useful for her in many ways. She learned many things, for instance she realized that she was/is an enabler [see glossary on page 555]. Before realizing that she was/is an enabler, she was busy taking care of Taro’s countless problems that were caused by his alcohol consumption, e.g. picking him up at the bar when he had quarreled, apologizing to the police when he was caught, etc.

“For example, I used to receive calls from our neighbors: ‘Your husband is sleeping at so and so street.’ or ‘Your husband is having a fight with so and so person at so and so bar.’ or ‘Your husband is injured at the street while drunk. You should go there and pick him up.’ Every time when that happened, I went out to pick him up and apologized to or thanked the people who were involved. I was doing such things all the time. I did it because my husband never did such things. It was always me who took care of these things. But since I learned that I should not do this for him, I started not to do them any more.”

For this interview, Ruriko said she talked about many things she hadn't told anyone else.

-----I hope your husband someday realizes his problem and thinks constructively what he has to do and puts these thoughts into actions.

“That is impossible, really impossible. I don't think that will....ever happen. [Ruriko paused.]

Because of the thing called alcohol dependence syndrome, I suffered a lot. My married life was really *donzoko* [very bottom of life, see glossary on page 555] throughout. I am lucky though since my children grew up to become relatively good and dependable adults.”

I thought, ‘Indeed, this husband may not notice his problem in his lifetime....’

Case 2. (The reason of my abstinence is that) I don't want to make my wife cry anymore.

Name				Age		Occupation								
Misaki Saito				54		Housewife								
Family						Husband's Occupation								
Nuclear		Extended		# of members		5		Service engineer of an electric appliance company						
Family members														
Matsuro		Husband		53		Alcohol related Incident (involved police)								
Misaki		Wife		54										
Kazuo		First son		22										
Kazue		First daughter		19										
Sachiko		Misaki's Mother		94										
Total Interview Time				Husband Attending Self-help Group?				Wife Attending Self-help Group?						
First: 1 hour 45 minutes Second: 40 minutes				Yes No				Yes No						
Wife's KAST concerning her husband's alcohol related behavior (See Appendix 1 on Page 546)														
1	2	3	4	5	6	7	8	9	10	11	12	13	14	Total
3.7	3.2	2.3	2.2	2.1	1.7	1.5	1.2	0.8	0.7	0.7	0.6	0.5	0.5	14.6
-1.1	-1.1	-0.8	-0.7	-0.7	-0.4	-0.5	-0.2	-0.2	0	-0.1	-0.1	0	0	
?	?	?	?	?	?	?	?	?	?	?	?	?	?	
Analysis (See Analysis on Page 489)														
A1	A2	A3	A4	A5	A6	A7	B1	B2	B3	B4	B5	B6	G1	
C1	C2	C3	C4	C5	C6	C7	D1	D2	D3	D4	D5	D6	D7	D8
E1	E2	E3	E4				F1	H1	H2	H3	H4	H5	H6	
Types of Problems (See Analysis on Page 489)														
Verbal Abuse		Physical Abuse		Financial		Psychological		Shirinugui		Child-Related				
Note														

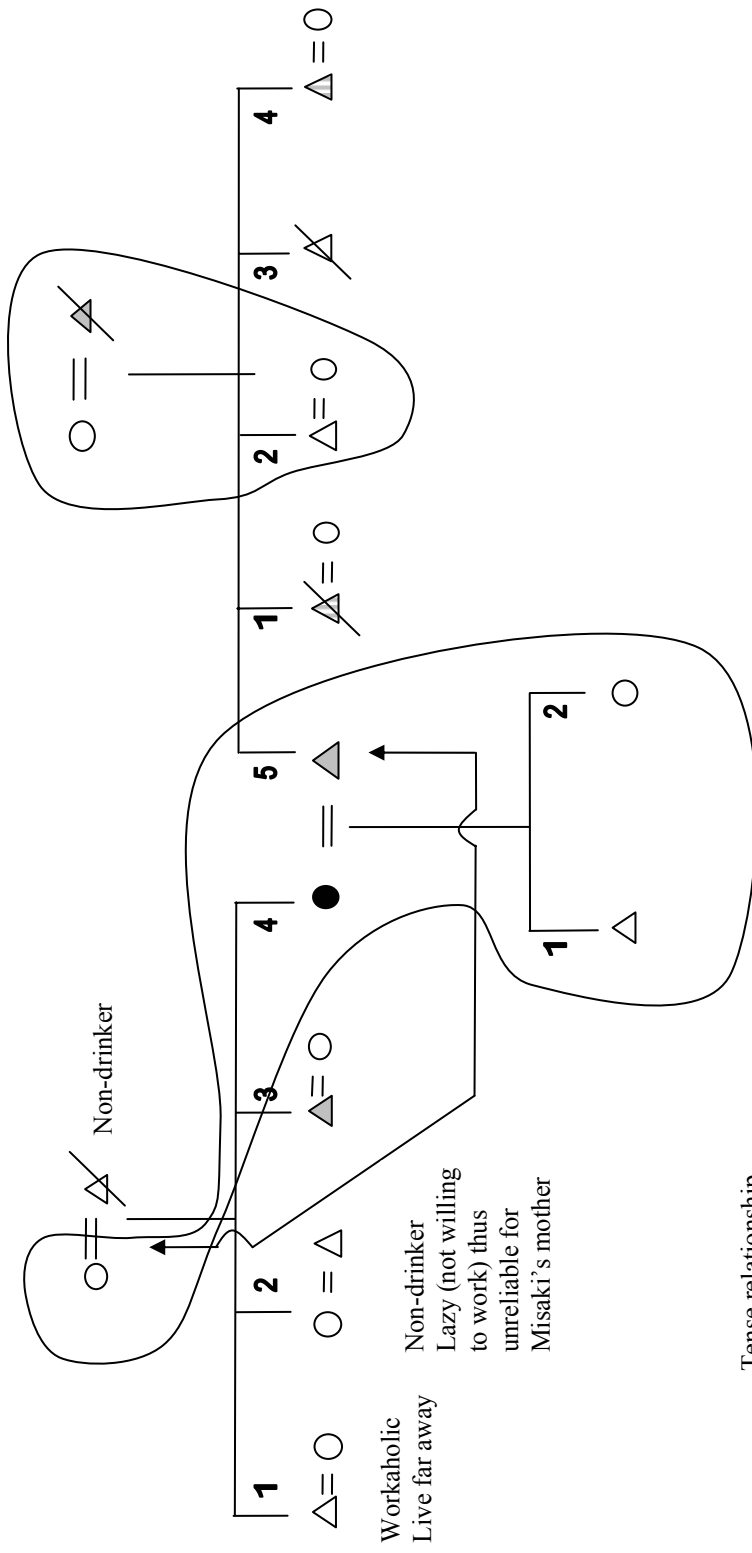

Misaki Saito

Misaki is a modest and quiet person. She appears calm, but this calmness was only possible because she just emerged from a long period of distress. Although Misaki's husband does not participate in a self-help group, he is currently abstaining from alcohol. I heard from someone else that, in the days when her husband's drinking problem was still severe, Misaki had a worn-out face, a very different look from how she appears right now.

When we arranged for an interview, she humbly said, "I am poor at talking, but I can answer 'yes' and 'no' to your questions." On the day of the interview, Misaki brought a stack of letters written by her acquaintance, which were all replies to her letters of distress during the days of her husband's serious drinking problem.

Adored husband

Misaki started her story.

"My husband knows that I am going to be interviewed today. This morning, before he left to work, I therefore asked him 'what shall I say to the interviewer if she asks me about the reason for your abstinence?' Afterwards during the day, I received a message in my cellular phone from him saying, '[the reason for my abstinence is because] I don't want to make mommy [Misako] cry anymore.' So, I answered to him, 'Thank you. I will convey your message to her.'"

-----That is a love letter!

She showed me the message of the phone with a smile on her face.

Love marriage

Misaki married for love. She met Matsuro [her husband] at the company where she used to work, and after being acquainted for 7-8 years, Misaki married Matsuro at the age of 30.

Matsuro is a service engineer at the electronic appliances company. Misaki describes her husband's character as kind-hearted, obliging, and considerate of other people's feelings.

As the interview proceeded, I came to understand that the relationship between Misaki and Matsuro is satisfactory. The relationship is also problem-free according to the domestic violence screening test [see glossary on page 555]. Beyond the absence of physical violence, Matsuro is a husband who does not even utter any complaint against her. In fact, Misaki's feeling towards him is such that she fondly related happy stories about their life during the interview without being asked. Every weekend, this couple happily goes grocery shopping together, a weekly event she likes a lot.

I asked one of the questions from the domestic violence screening test.

-----Do you think that your husband is thinking that you cannot do anything without him?

“Yeah, probably, He may be thinking that I am so stupid! [Misaki, laughing]”

Because of her tone, I regarded these words as a humble joke and not something that puts her into a corner in reality. Misaki mentioned that there was one time in their married life

when Matsuro overturned the table because he was mad. This event was however unrelated to his drinking, and according to her way of speaking, it did not seem to bother her much.

Misaki's thoughts on her husband's drinking

----- What did you think about your husband's drinking before marriage?

“Our relationship was a relationship that did not involve any alcohol. I myself do not drink. So, when we had a date, we often went to coffee shops. He ordered coffee and I ordered tomato juice. I did not know how he drank.”

----- How did he drink after getting married?

“He is a person who becomes rather amusing when drunk. He starts singing, or sometimes plays the guitar.”

Often he drinks alone. As described earlier, he never accuses Misaki. However, as the interview progressed, I learned that he does grumble about his workplace to Misaki quite frequently.

“There were times when he was drinking and complaining, such as ‘I am working hard, but that a fellow (colleague) regards me as stupid.’”

----- Could you talk about the first time you thought that your husband might have a drinking problem?

“It was when one of the children was still going to kindergarten [approximately 18 years ago]. His superior at work was loafing on the job, playing mah-jongg during the day. Knowing this, on the occasion of drinking with colleagues, he complained about it and lost his temper and flung a glass at the superior, which became a struggle. On the next day, carrying the child on my back, I went to the superior’s place and apologize for what my husband had done. [Misaki paused.] I am not sure, but I think my husband’s colleagues already regarded him as a ‘heavy drinker’ from this time.”

The cause of husband’s drinking: relation with his mother-in-law

Misaki believes that the cause of her husband’s drinking is the combination of (1) a bad relation with his mother-in-law and (2) pressure at work. Misaki’s family moved in with Misaki’s mother to care for her in her old age. Throughout the interview, she emphasized that, one day, the until-then-happy-nuclear-family suddenly turned into an extended family which is full of restraints. Currently, they are living with her 93 year-old mother.

“My husband’s problematic drinking only started when we moved here [current residence] and started living with my mother [to care of her in her old age]. I believe that was approximately 16 years ago. Those two [husband and his mother-in-law] just don’t seem to get on with each other. My mother’s dislike of him shows in her attitude as well.”

Even now, these two eat meals separately; while Misaki and her mother eat downstairs, Matsuuro [husband] eats upstairs alone. Misaki continued,

“Until then, the four of us were living freely. But now with my mother, our family is not free like it used to be. In the past, we used to travel frequently such as going for camping at the beach. We haven’t done these kinds of things for the last several years now. You see, we can’t just go out leaving grandmother at home. We feel sorry for her. There are many things we can’t do because of the hesitation we feel for grandmother.”

----- Aren’t you the last child, Misaki? How come your mother is not living with the eldest son, but living with the youngest child, which is you? [In Japan, it is common for parents to live with their eldest son.]

“Yes, and that is the problem. From my husband’s point of view, it is natural for him to complain ‘why do I have to live with wife’s mother.’ Well, this is because my oldest brother lives in Kyushu, a place very far away from here. And the second child’s family, that is my sister’s family, they are nice, but sort of lazy people. They are, in other words, unreliable for this kind of thing [taking care of grandmother]. Since my marriage was late, I spent a relatively long time with my parents. This may sound arrogant, but, it is only me who can take care of our mother. It was this situation which led my husband to reluctantly accept to live with my mother. At the beginning, things were working fine because of my husband’s careful considerations. But, as time passed, since these are matters of every day life, my husband couldn’t bear living with my mother any more.”

Recently [around the period of the interview], Misaki's family, again had trouble related to this problem. The outer wall of the present house, which is also Misaki's mother's residence, needed repair. For this, the husband's salary was used.

“My husband was upset. He must have thought, ‘Why do *I* have to pay for this?!’ These days, his own mother's senile dementia has worsened. Because of this, his older brother's family, who are taking care of Matsuro's mother, had to put her into a special care facility. Since moving into this kind of institution is costly, our family decided to contribute some money to that as well. After a family council [Misaki's family], we decided to reduce Matsuro's pocket money and the children's monthly cellular phone allowance. Since it was at such a time, it is understandable that my husband got upset for giving up his salary for grandmother's house's repair. [Misaki paused.] So, one day, I received a long message on my cell phone from my husband saying, ‘We will divorce when the children are grown up.’”

Considering the love letter he sent to her on the day of the interview, the problem was probably settled by then. Misaki also says that her husband was very emotional at that time and that the voice mail sent to her was not out of his real intention.

Wife's attitude toward husband's problematic drinking

Unlike the stereotype of the violent drinker, Misaki's husband drank quietly when he became an alcoholic.

“I often thought ‘Oh no... He is drinking again...’ But I knew he was taking pleasure while drinking. In addition, I felt obliged to my husband for him living with my mother. Because of that, although I felt I did not want him to drink, I tried not to accuse him for it.”

One day, finally, her presentiment of her husband’s encountering danger due to alcohol became a reality. Approximately 7-8 years ago, he caused a traffic accident because he was drunk driving.

“It was around this time that I started to worry about his drinking problem constantly. He was always drinking, literally every day. Sometimes he was drinking from the morning before going to work. It seems like he needed the alcohol just like we drink water when thirsty. There were occasions when he was pretending that he was drinking water; but looking closely, the cup was filled with an alcoholic beverage.”

Misaki gradually became involved in her husband’s drinking problems. She started checking his alcohol consumption by secretly putting a line on his bottle every day. She also thinned the liquor with water when he was not present.

“Of course he noticed when I diluted the liquor. So, eventually, he started storing his drinks in his car’s trunk and drank several cups before entering the house after work. There were several times when he was sleeping in the car, and my son had to carry him to his bedroom upstairs. There were times when he was unable to walk. He sometimes collapsed on the

floor. There was also effluence at the toilet. If this is the toilet seat [Misaki drew an ellipse], this is where you put your legs [she pointed two areas on both side off the ellipse]. Here [pointing at the one outer edge of the pointy part of ellipse], he was lying on the floor with his pants all wet.”

One day her husband stole his children’s money from their desk to buy drinks. It happened when he was going through recuperation at home which was recommended by his doctor.

“In those days, I was strictly managing his salary. I did not allow any pocket money to him, not even an amount to buy a can of juice. If I did so, he would go out and buy alcohol. I didn’t want him buy ‘one-cup’ [a popular 180 ml *sake* product, 198 yen \approx U.S.\$1.8] at the vending machine. I also hid my wallet. My husband, however, went to his children’s rooms, filched some money from their desk’s drawers... He went this far, just to buy alcohol. He did this at least twice during the period of recuperation at home.”

As the days passed, he started skipping work. Because of the absences, the company sentenced him to dismissal, telling Misaki that “there is no longer a necessity to keep your husband in the company.” Misaki pleaded to his superior, “I will hospitalize my husband and get him back on the right track. So, please give us one more chance and do not fire him.”

Misaki was desperate. Around this time, her mind was concentrated on stopping her husband’s drinking, which led her to consult her siblings, her husband’s siblings, and

even a new religious organization. The letters she brought on the interview day were letters from the staff or leader of the religious organization. They were replies to Misaki's letters which elaborated her troubles due to her husband's physical problems, the company's plans to fire him and also her difficulties to cure his drinking. The letters she brought were beautifully written in a kind and polite manner. Considering the fact she is keeping these letters with special care [she kept them in a special bag], one can easily imagine that Misaki was touched by these letters and read them repeatedly.

Hospitalization, two times

When Misaki consulted with Matsuro's older brother, he said to her husband, "Matsuro, this is it. [≈You must stop this right now.]" And with the help of this brother, Matsuro finally agreed to enter the hospital. Worrying about the impression given to the company and other people, he entered the hospital under the diagnosis of "depression." [Diagnosing necktie-alcoholics with 'alcohol related disorder' and not with 'alcohol dependence syndrome' seems commonplace.] The first hospitalization was at the psychiatry section of a large hospital, which does not specialize in the treatment of alcohol related problems. Contrary to Misaki's expectation, during the time of this hospitalization, he was drinking whenever he had the opportunity to leave the hospital and buy alcohol.

The second hospitalization was at the special hospital for alcohol related problems. Two days before the hospitalization, her husband said to Misaki: "I will abstain. And today is the last day. Let me have a final drink in my life." He finished his last alcohol. This was what one may call "the man's own ritual of abstinence." Since that day, he has continued his abstinence. Misaki continued,

“But one day, after this second hospitalization, some unpleasant things must have happened to him at work. He came back home with a 720 ml bottle of *shochu* [white distilled liquor]. I was alarmed and asked, ‘What happened to you?!’ Then, he answered, ‘Let me place this bottle in my room. I just want to look at it.’ [Misaki, laughing.] The bottle has long been kept closed in the room until recently [closed for 2 years and 5 months].”

-----Are you sure? Could it not have been replaced with water? [I was half joking.]

“In fact, it wasn’t water. About a week ago, my son invited his friends, opened the bottle and drank it. He said it was not water. [Misaki, giggling].”

Since then until now, he has been abstaining for 2 years and 8 months. Even today, he still seems to have the craving for alcohol. Because he is scared of drinking and is not confident about his discipline to abstain, he always excuses himself from [company-related] parties that involve drinking, such as the common drinking party, the year-end party, the New Year’s party, the welcome party, send-off party, etc.

Divorce

-----By the way, have you ever considered divorcing him since you couldn’t tolerate the situation?

“Yes. I have thought about divorce...from my side. But since I couldn’t financially live without him, I decided not to. So, I was really thinking to stop his drinking.”

There was a time when she wanted to die at the nearby seashore in the middle of the night.

-----Has the “presence of your children” ever got into your way for such things?

“No. When it comes to the husband’s drinking, I was often helped by my children. One day, for instance, I could not bear the situation any longer. So, I said to my children, ‘Mom [Misaki] is going out to cool myself down.’ I said that I am driving to the seashore. I believe it was around 11 p.m. My oldest son said to me with an earnest face, ‘Don’t do anything strange.’ Did you know that sea in the night is quite fearful? [I nodded.] I changed my mind after all, and decided to visit my girlfriend whose husband is a business bachelor [living away from his family because of his job, see glossary on page 554]. During that time, I was called by my son on my cell phone several times. He was anxious about my safety. Later, I returned home quietly. It was around 2 a.m., when my husband drank himself to deep sleep.”

Children

There was a time when this oldest son could not bear his father’s deplorable figure, either. One day at the age of 18 or 19, he ran out of the house.

“With a parting shot ‘I don’t want to see such a father,’ he didn’t return home for at least 2-3 days. It seems like he was going to school during that time, though. Later I heard that he was staying at his friend’s house.”

Such children are also victims of child abuse. Misaki confessed that she frequently scolded her children, especially her oldest son, for every little thing they did.

“I struck and kicked my children. This was far from ‘disciplining’ them. I was impulsively hitting my children. Seeing this, my mother reminded me several times, ‘You are bullying your children. It looks like you are taking out your frustration on them.’”

These children, however, are now thankful to their mother for her strictness according to Misaki. She, also, is proud of her children – they are always well mannered. The oldest son recently started working. Although he is only 20 years old, he helps out with the family budget and even gives his younger sister some pocket money. He is also kind and considerate and gives his grandmother a New Year’s present [money] on New Year’s Day.

Mother

-----So, does your mother know that she is one of the causes of your husband’s drinking?

“No. I don’t think she notices it at all. Perhaps, she doesn’t even know that Matsuro [husband] has alcohol problems either. Also about the quarrel between me and my husband, she might be thinking that he is simply being hard on her daughter.”

The following question was asked towards the end of the interview.

----- If *any* kind of your wishes would be granted, what did you wish for when you were in the midst of the trouble? You could say, for example, “I wanted sufficient money to divorce him” or “I wanted to leave the kids to start a new life” etc. Please answer regardless of the social norms.

“Honestly speaking, I sometimes feel that it might have been better if we hadn’t lived with my mother. I should never say this, but I sometimes think ‘I wish mother is not here... Why does she not just die quickly?’ A scary thought. I am afraid of myself for thinking such a thing and feel that I am such an ugly person. What a shame... [Misaki, with a sad look on her face]”

One day, the oldest son suggested, “Why don’t mom and grandma live separately from dad until grandma passes away?” When Misaki asked, “How are we going to manage the money?” the son answered “We (i.e. I) will pay for it.” Although this plan was not carried out, Misaki cannot forget her son’s words.

Advice

At the very end, I asked Misaki for advice for wives of alcoholic whose husbands are non-violent.

“I think it is important to remain calm. This is really very difficult. I was careful about my wording. Instead of saying ‘Stop drinking!’, I said something like, ‘Did you have enough? Don’t you want to call it off for today?’ Moreover, I tried not to lose my temper. It’s like changing him with a flexible attitude and due respect. For this, it is important that you yourself change, too. I hear stories of women becoming strong and getting angry unsparingly. I don’t think this is a good idea. I believe there is something that goes beyond language in the relationship of wife and husband; something that enables us to understand each other without saying everything.”

Case 3. A husband who “hates” medical institutions

Name				Age		Occupation									
Haruko Toda				65		Restaurant business									
Family						Husband's Occupation									
Nuclear		Extended		# of members		4-9		Chef (Japanese style)							
Family members															
Taro		Husband		67		Diagnosed with alcohol dependence syndrome and diabetes.									
Haruko		Wife		65											
Kazuko		First daughter		38											
Tome		Taro's mother		94											
Mitsuo		Taro's father				Deceased (6 years ago)									
Total Interview Time				Wife Attending Self-help Group?				Husband Attending Self-help Group?							
1 hour 40 minutes				? (Probably No)				Yes No							
Wife's KAST concerning her husband's alcohol related behavior (See Appendix 1 on Page 546)															
1	2	3	4	5	6	7	8	9	10	11	12	13	14	Total	
3.7	3.2	2.3	2.2	2.1	1.7	1.5	1.2	0.8	0.7	0.7	0.6	0.5	0.5	17.2	
-1.1	-1.1	-0.8	-0.7	-0.7	-0.4	-0.5	-0.2	-0.2	0	-0.1	-0.1	0	0		
?	?	?	?	?	?	?	?	?	-0.2	?	?	?	?		
Analysis (See Analysis on Page 489)															
A1	A2	A3	A4	A5	A6	A7	B1	B2	B3	B4	B5	B6	G1		
C1	C2	C3	C4	C5	C6	C7	D1	D2	D3	D4	D5	D6	D7	D8	
E1	E2	E3	E4				F1			H1	H2	H3	H4	H5	H6
Types of Problems (See Analysis on Page 489)															
Verbal Abuse		Physical Abuse		Financial		Psychological		Shirinugui		Child-Related					
Note															

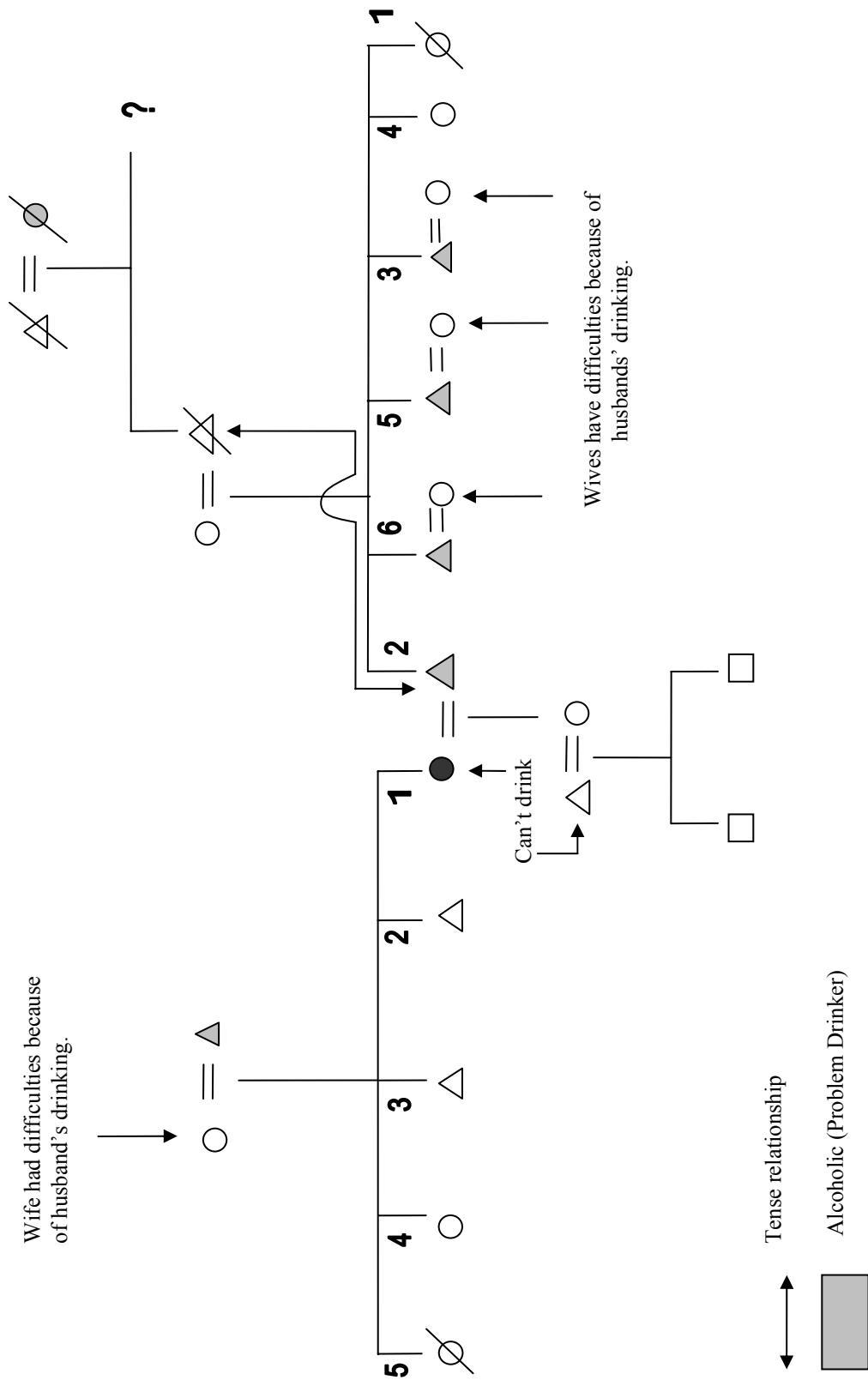

Haruko Toda

It is often said that an alcoholic's spouse has a "reliable character." Haruko is someone who fits this saying. In the Toda family, Haruko manages everything in the household. Without her, the household would have collapsed a long time ago.

A Husband who hates medical institutions

Haruko's husband strongly hates medical institutions. He is someone who bears the pain and does not consult the doctor until the last moment. The grandfather [Taro's father, who died a few years ago.] consulted a doctor about his son's drinking problems six years ago. Taro has been examined several times when he was seriously ill. Although his alcohol problem has long been pointed out by medical doctors, he is not receiving proper medical treatment for his alcohol dependence because he refuses to continue to go to medical institutions.

As usual, I started the interview by telling the interviewee Haruko about the purpose of this research and my promise to protect her privacy in various ways. During this time, Haruko was nodding which appeared to me as if these promises were of no concern to her. At that moment I said that her story will only be written in English and will not become accessible to general Japanese audiences, she smiled and murmured, "I wish it would come to the eyes of the general public."

As mentioned earlier, Taro hates medical institutions. My interview with Haruko started from the story of Taro's gangrene [decay or death of body tissue when the blood supply is stopped]. Taro had gangrene in his toe. One day he accidentally cut his toe while cutting his toenails. It was bleeding but he did not feel the pain because of his diabetes. He

treated the injury using his self-taught medical skills. He stopped the bleeding by binding his toe tightly with a rubber band. He did not go to the doctor. Three days later, the wound became pitch-black. However, he still did not go to the doctor. [If he had received proper medical treatment at this point, he would not have lost his foot.] This time, he applied poultice to the wound and endured it for another week. The cut worsened rapidly and released a nasty odor. [Haruko's description of her husband's stinking wound was so vivid that I could almost smell it.] Haruko, who could no longer tolerate the situation persuaded and even forced him to consult a doctor. When the doctor saw Taro's injury, he scolded him, "Why did you leave it until it became like this!" On the spot, he was hospitalized and half of his foot was amputated.

Thanks to the operation and daily disinfection, the wound healed rapidly. During this time, he was diagnosed with alcohol dependence syndrome [I did not ask about the details of this examination.] which required 3 months hospitalization for him. He was unhappy during this time because of the loss of his foot, the unsavory hospital food, and his denial of his drinking problem. When his blood sugar level went down to 380, he complained "Why do I have to be in such a place!" and left the hospital. This was one month after he had been admitted.

Before marriage: I used to think, "It's okay if my future husband is a drinker"

Taro's brothers are all heavy drinkers. All of their wives are suffering from their drinking problems. Although Taro's parents both seldom drank, his father's mother drank a lot. Haruko has heard that her mother-in-law drinks alcohol like water, and even drank during her pregnancy.

Haruko's father was also a drinker. Her mother was often suffering from his drinking problem. Therefore, her mother frequently told her children never to marry a drinker. However, contrary to her mother's experience, Haruko did not necessarily regard her father's drinking as bad; she sometimes even thought that marrying a drinker is "rather okay." There is warmth in the tone of Haruko when she recalls memories of her father's drinking.

"My father was a cheerful drinker. When he drank, he started singing songs and created a pleasant atmosphere in the house. Since he often went to several bars in one night, my mom didn't like his drinking. I have many good memories of father's drinking.... For example, we used to live in Tokyo until I was 5 years old. When father went out for a drink, he sometimes brought home a stranger with whom he had had a good conversation at the bar [Haruko laughed]. In this situation, he returns home happily with a stranger. Dad seems to be on very good terms with the stranger, asking mom to serve food, provide a bath and a bed and so forth. He created the impression that the stranger was his good friend. But the next day when he wakes up, he could not remember who the stranger was! [Haruko laughed]. There is another story from this period when we were in Tokyo. One day, father went for a drink, became drunk and didn't return home because on his way home, he got lost and fell down a cliff in a small wood [Haruko laughed]. There is another one. On the day before our moving to Tohoku [the current place], he suddenly started to throw a tantrum saying, "I'm not leaving Tokyo!" and invited his neighbors and started a drinking party. Because of the purchased train ticket, mom worked very hard, pleading with him until dawn, to persuade father to leave Tokyo on that day [Haruko laughed]. My dad was a

person who did such crazy things. And surely mother suffered because of this. But since father was a happy drinker, for me, ‘drinker’ was acceptable as a future husband.”

Marriage

Haruko’s marriage was an arranged marriage.

“I was informed that ‘Taro owns a business, and he drinks. He is also a very quiet [almost taciturn] and serious person.’ And I took the whole story on faith [Haruko laughed]. What a terrible mistake I made!” [Haruko laughed and paused.] Although mom used to say that I should not marry a drinker, I didn’t really dislike drinkers. And I am also a person who is good at not following mother’s words. [Haruko laughed and then paused.] But contrary to my expectation, the way Taro drank was very different from my father’s drinking style.”

----- Didn’t you notice that before your marriage?

“No. I got married at the age of 26. This is considered a ‘late marriage’ since it was common for women to marry around the age of 20 or so at that time. Therefore, in those days, my parents pressured me saying, ‘if you don’t get cleared away [≈if you don’t get married], all other children they don’t get cleared away either [it’s not good for younger siblings either]. So, hurry up with your marriage.’”

Husband’s drinking habit

Taro becomes querulous when he drinks.

“He turns especially on his father.”

----- *Kotoba no bouryoku* [verbal violence]?

“That’s definitely violence. [She said it in a determined tone]. He says things such as ‘I didn’t become a chef because I wanted to,’ ‘If I had gone to university, I wouldn’t be having this kind of life now,’ and ‘There is nothing beneficial to being born as the oldest son.’ He is like a scratched record: he says the same things over and over again.”

Hearing her expression “scratched record,” I laughed involuntarily.

“I am serious. He is really like a scratched record. He complains about the same thing over and over, and over again. He says these things only when he is drunk. I wish he talked half as much as he talks while drinking when he is actually sober. One day, in order to make him realize how obnoxious he is when he is drunk, I taped his grumbling when he was drinking. And on the next day when he was sober, I asked him listen to it. But, it was of no use. He simply replied, ‘this is not me,’ and that was it.”

-----He must remember, at least a little bit.

“Well, I don’t know. I think he meant what he said, though...By the way, I have also taken his picture, too. [Haruko laughed and influenced by her joking tone, I laughed involuntarily

again.] My husband is a person who can't accept his destiny, who had to inherit his father's business, and reclaim his life within it. He can't do anything but complain and accuse others for his dissatisfactions. It is deplorable.”

Husband's attack against his father

----- According to your stories, your husband seems to maintain ill-feelings which are due to his duty as the oldest son to inherit his father's business. Do you think this is somehow also related to his excessive drinking?

“Yes, I do.”

The husband inherited his father's Japanese-restaurant. In Haruko's eyes, Taro seems to be a very skilled chef.

-----If he was not doing this business, what would he be doing then?

“I think he wanted to go to university. [He graduated from an elite high-school in the region.] He couldn't do this because he says that he didn't have 15,000 yen to take the entrance exam. Since his high-school friends and seniors who went to university now have respected positions at big companies or at public institutions, he might have been able to do such things if he had also gone to university. Probably that is what he wanted to be.

[Haruko paused.] But you see, 15,000 yen is not necessarily a very big sum. I think if he really wanted to take the exam, he could have made an effort such as by working part-time

and earning the money by himself. But saying this is of no use. He becomes angry when I say these things.”

-----So the target of your husband’s anger was his father who forced him to choose this profession?

“Yes. The verbal violence was always turned against my father-in-law.”

-----Why is that against his father and not his mother?

“Although my mother-in-law was the bride who came into the Toda family [the wife usually has a low status in the house], she came in with substantial property, which gave her a relatively high status. She had the initiative. My father-in-law, on the other hand, is the opposite character from my mother-in-law. He is not a leader type, but rather a person who is often ignored. He was rather like ‘a groom who married into the family of his wife,’ as some people actually said. Perhaps that is the reason [why mother-in-law was not attacked by her son].”

----- Was there any physical violence?

“There were several times when Taro was violent against grandfather, such as pushing and kicking him. Since my father-in-law was a short and skinny person, he easily fell on the floor when this happened. My poor father-in-law! I was always very sorry for him.

Sometimes Taro shouted at his father, 'Die!' When I couldn't tolerate the situation of him abusing his father, I threw things at my husband. This way I meant to stop my husband. But when I throw things, since my husband is too good at dodging, the object misses him. I broke furniture, window etc. Since throwing things doesn't bring you any profit, I really recommend you not to do that."

-----Was there any physical violence against you or your children?

"No. There was none against the children. I believe there was none against his siblings, too. Regarding my situation, as I said before, it was me who was being violent against him rather than him being violent against me [Haruko laughed]. There was once when he slapped me because I said something which I don't remember. When this happened I remember I attacked back."

-----Do you think the family members are careful not to disturb your husband's sensitive feelings, which contributes to the non-violence towards the other family members?

"Yes. There is definitely that aspect. My husband's brothers always speak with respect and appreciation, 'Everything that was possible is due to the big brother [Haruko's husband] who inherited the house.' And by saying such things, they endure most of my husband's selfish behavior as well."

Husband's drinking habit

Taro often drinks, but he does not necessarily drink every day.

“When he wants to, he can easily drink 1 *sho* [1800ml \approx 0.477 US gallon] of *sake*. He usually takes a long time to drink it. He can drink fast though. There was one time when we received a 12 pack of 500ml beer bottles as *Ochugen* gift [midyear present]. He drank all of them in two hours.”

-----Who goes out and buys such large amounts of alcohol?

“Most of the time, it's me who goes to the liquor store. You may think I shouldn't do that, but I can't help it. If there is no alcohol, he makes a big tantrum in the house and it would be either my mother-in-law or father-in-law who will be sent to the liquor store to buy his alcohol. My husband going himself? Never! He seldom goes out to buy his own drinks.”

Taro sometimes drinks moderately. And there are times which he does not drink at all. It is common for him not to drink at all for one or two weeks in a row. A long time ago, there was one time when he abstained for 5 years since his favorite uncle passed away, but then he start drinking again. For the last 3-4 years, he has been drinking in moderation. Because of this, he currently suffers from serious insomnia. He endures this not by taking medicine but by spreading slices of onion all over the bedroom.¹⁴ Occasionally, there is a meeting of

¹⁴ Placing minced onion in the bedroom to sleep better:

A few Japanese internet sites explain that the allyl sulfide contained within onions helps to absorb vitamin B1 in humans' body and thus is useful for insomnia. (Lack of vitamin B1

a town association, which serves alcoholic drinks. Taro says abstaining in this kind of occasions is very tough for him since he still craves alcohol. [He therefore sometimes drinks at these meetings]. But since there is the threat from Haruko, “if you drink once more, I will divorce you,” Taro somehow manages to continue his moderate drinking life.

-----Does Taro participate in self-help group meetings, such as *Danshu-kai*?

“He does not even go to the doctor. He will never go to a self-help group. He would probably think, ‘For what [do I have to go to such places]?’ Sometimes I hand him the pamphlet written about alcohol dependence syndrome, but he shows absolutely no interest. Sometimes, I say to him, ‘why don’t you take a look,’ but that is of no use as well. He thinks, ‘I am not suffering from alcohol dependence syndrome,’ ‘I am not so bad.’”

Husband who suddenly disappears, and his wife who cleans his mess

Haruko tells about her husband’s drinking habit as follows.

“He likes to leave the house when he drinks. With 3 *gou* [541ml \approx 0.14 US gallon] of *sake*, he starts gadding about as if he is fueled with gasoline. He goes to the store or to relatives, and causes trouble. He always suddenly disappears. So when this ‘sudden thing’ happens, I always become worried.”

-----Why do you become worried?

can cause symptoms such as tiredness, poor appetite, sleeping disorder, irritation.)

“I worry because he might be causing trouble to other people. This happens all the time. Sometimes I get a call from a relative, saying ‘he is troublesome, so please come and pick him up.’ I receive such calls from restaurants, too. One day, in the case of a *sushi* shop, I bought confectionery and apologized for what he had done on the previous day. Once I received a call from my husband in a restaurant saying, ‘Come with your money.’ It seems like he left the house, as always, and went into a store without carrying his wallet. I responded ‘No, that’s none of my business!’ and hung up, but, he called over and over again so that I had to go and pick him up after all. [Haruko paused.] There was also a call from a bar asking me ‘please come and pick up your husband.’ I replied, ‘I am afraid I will not go and pick him up. Please call *kouban* [local police station with 2-3 officers] or do whatever needs to be done.’ At that time, I didn’t give in, and one of the bar staff sent him back home after all.”

-----Has he ever caused trouble which involved the police?

“No, that never happened.”

Concerning drinking and police, however, these people do have experience of having drunks coming into their house.

(<http://www.o-e-c.net/syokuzai/tamanegi.htm> accessed July 15, 2004)

“We live very near to a bar. So, once in a while, there are drunkards coming into our house believing that our house is their house [Haruko laughed]. One day, I heard a noise at the entrance door. I thought that it was my drunk husband coming back home like usual. But unexpectedly, there was a strange drunk man sitting on the steps of the entrance room. My husband, who happened to be in the house, came and had a conversation with this stranger after all. It sounded as if he was encouraging the stranger. It also happened that someone knocked on our door in the middle of the night. When I asked ‘who is it?’ the strange man replied ‘it’s me!’ He was convinced that our house was his own home. You know, it is really scary to have somebody visiting your place in the middle of the night. In this case, we called the police. There were occasions when we called the *Mama* [female manager of night clubs, see glossary on page 556] of that bar to take care of him. This happened to us three times.”

-----Where does your husband drink more often, outside or at home?

“Probably outside. He often ‘suddenly’ disappears and drinks ‘outside.’”

-----Does that mean that his grumbling habit when drunk does not happen very often?”

“No. The scratched record happens after he comes back home. He first drinks a little at home, suddenly disappears, and then, late in the evening, he comes back drunk and complains about the same thing over and over again.”

Awareness to the problem

-----When was the first time you encountered a situation where your husband caused trouble related to his drinking?

“I think it was about five or six years after our wedding. Our child was still in kindergarden. One day, we went to my parents’ house to leave our daughter there. On our way back home in the train, my husband suggested we go to a bar together. Since I do not drink [she feels her heart beats fast and becomes ill when she drinks], I refused, saying, ‘I don’t want to go to such a boring place.’ He then became angry. Well, I am also a stubborn woman. At the time when we arrived at our station, we were both in a bad mood. We decided to move on separately and he went to a bar and I went straight back home. Later on, he complained about my behavior over and over again. It was since around this time when I started to realize that he changes when he gets drunk, he grumbles when he is drunk, and thought that I will try hard to make him not drink.”

----- Tell me about the time when you started to think that your husband definitely has a drinking problem.

“It was around the time when my daughter graduated from high school. It appeared as if he had finished the duty of his life. He always drank and didn’t work. It was crazy. I really thought of divorcing him.”

It has taken ten years or more from the day Haruko noticed her husband's drinking problem until she came to view him as an alcoholic. Considering the fact that the daughter is now around 40 years old, Haruko had been suffering for more than 20 years until she noticed that her husband was an alcoholic.

-----Was there anyone with whom you could consult about this problem?

“Yes. I had a friend in my neighborhood with whom I could talk about such problems. My brother-in-law also took care of us in various ways. I appreciate him for all the things he did for us. For example, I consulted him about our financial problems one day because my husband was drinking all the time and wasn't working at all. When my brother-in-law heard this, he employed me at his restaurant as chef assistant. I worked under him for over 20 years. Well...if the husband doesn't work, the wife has to be the breadwinner, right? My daughter scolded me saying, ‘You are spoiling dad because you are doing everything for him!’ Even my husband says, ‘You are the one who is bad because you do everything for me.’ But what shall I do then in a situation like this?” [Haruko smiled.]

---- Have you consulted a specialist at a public institution, such as at the health center?

“I haven't. But my daughter has been to such a place. I believe that was when she was 19 or 20 years old. But, it was really no use. You see, my husband does not necessarily become violent when he drinks. I remember she was told by the officer ‘Call the police when he becomes violent.’”

The cause of husband's drinking

As described earlier, Haruko sees a connection between his drinking and him being the oldest son who was destined to inherit his father's business as well as taking care of his parents. I was curious if there are any other reasons for her husband's drinking from his wife's perspective.

“He tends to drink when he is in trouble. For example, a long time ago, our son wanted a driver's license. [Getting a driver's license is very expensive in Japan; approximately 300,000 yen \approx US\$ 2,727 these days.] When my husband was asked for the money, I remember he was troubled how he could manage the household budget and started to drink. A similar thing happened for one of his brother's marriage ceremony. When this happened, we organized a family meeting for how we are going to manage the budget for this event. But before the family council, he worried about it by himself and thus drank; and by the time his siblings came for the gathering, he was already drunk and was unable to participate properly in the discussion. It would be at least somewhat useful if he finished some work and then got drunk instead of being drunk before accomplishing anything.”

Wife and mother-in-law relationship

There appears to be no wife and mother-in-law problem in this house. Since Taro's parents are aware of his abusive problem, they are rather on Haruko's side. The parents do not complain about Haruko, even when she uses violence against her husband. Haruko says that perhaps the relationship between her and her parents-in-law is better than that of Taro

and his parents. These days, Haruko is busy taking care of her 94 year old mother-in-law who is confined to bed. It appeared to me that members of her family are very dependant on Haruko. Haruko also thinks that she is the target for dependency in the family. However, if she has spare time, she would rather work diligently and get one or two more additional tasks done then complain. That has long been her motto, and now it is the way she lives.

Character of the husband

“At first glance, Taro looks gentle, and far from the general image of ‘alcoholic.’ When someone visits our house, he is polite and comes out from his room to the living room to say hello to the visitors. When my daughter’s best friend visited our house one day, her first impression of her friend’s father was ‘a frank gentleman.’ When my daughter said that he has alcohol problems, she replied, ‘No way! [I can’t believe that.]’ Then, one day, after this visit, she visited our house when he was drinking and grumbling. When she saw that, she said to my daughter, ‘What you said last time seems to be true.’”

Haruko’s feelings

----- If you could wish for anything, what did you wish for when your problems were most severe? You can say, for example, “You wanted to divorce him,” “You wanted to kill your husband,” or “You wanted more money to divorce him” etc.. Answer freely, regardless of the social norms.

“I really wanted to fly away from where I was.” [Haruko talks while staring into the distance.]

-----Momentarily or permanently?

"Forever."

----- Do you mean that “you wanted to divorce him”? [Haruko nodded.] Then what is the thing that prevented you from doing so?

“It was for my daughter, and for my mother who opposed our marriage in the first place.”

-----Was there any financial problem which prevented you from divorcing him?

“No. In terms of money, I didn’t have a problem.” [Haruko smiled.]

-----For you, his grumbling was the biggest problem, right? Do you think you will be satisfied with him if he doesn’t have this problem?

“Yes. If there is no grumbling, that would be extremely good. What can I ask for more than that!”

-----But this is probably more difficult than divorcing him, correct?

“Absolutely.”

Hopes for the future in society

----- Is there anything you want or expect from society to improve this problem? Please tell me any change you think is needed, such as change in customs or change in the social system.

“I think the heredity system is a problem. I believe determining the first son’s destiny by forcing him to inherit the father’s business is a wrong custom. My husband’s life was a life of sacrifice just because he was born as the first son. It is true that inheriting his father’s business makes more profit than him working for a company or public institution. But, why can’t parents respect him for pursuing his own future dream first and then consider their own business second? I think this would have been much better for my husband. [Haruko paused.] In addition, my husband was trained as a chef under his father’s skilled supervision, after he graduated from high school. Doing this was probably more economical than him going outside as an apprentice under the supervision of other good chefs. But, I think it would have been better if he had gone outside for at least two years. Taro indeed acquired the chef skills from his father, but he missed the opportunity to learn social skills. Because the trainer was his father, things were learned through the father-son *amae*-relationship [see glossary on page 554], which prevented him from learning the social skills of not doing *amae* [having the mentality of things being accomplished passively ≈ having a child mentality] in society.”

She also proposed the following wish for society.

“I wish we had a place where we could freely consult about our husband’s drinking problems and be helped. When a problem occurs, for us, it requires a lot of courage to call the police. I would be very thankful if there was a place where one can call without much hesitation when a problem occurs. It would be great if there was a place, a place like the public health center, where specialists like the counselors come and we can consult about our problem frankly. It would be great if those specialists were also laid-back people who can calm the situation down by hearing our stories as well as telling us their stories. Not people like policemen, but people like friends who come more casually. If there was a service like this, it would help my life a lot.”

As in the case of Haruko, there are many women in Japan who suffer from their alcoholic husbands who refuse to consult doctors. There are also many women who suffered throughout their lives and their husbands deny their problems until the end. Without such troubles, I wonder what kind of exciting lives these women could have had.

Case 4. This is my fate. It is predestined from my previous life.

Name		Age		Occupation										
Chika Meguro		41		Housewife										
Family			Husband's Occupation											
<input checked="" type="checkbox"/> Nuclear	Extended	# of members	7		Salesman of an electronic appliance company									
Family members														
Jiro	Husband		Alcohol related incident (police involved)											
Chika	wife	41												
Kazuo	First son	17												
Kazuko	First daughter													
Tsugio	Second son													
Mitsuo	Third son													
Tsugiko	Second daughter		Kindergarten											
Total Interview Time		Wife Attending Self-help Group?		Husband Attending Self-help Group?										
3 hour		Yes <input checked="" type="checkbox"/> No		Yes <input checked="" type="checkbox"/> No										
Wife's KAST concerning her husband's alcohol related behavior (See Appendix 1 on Page 546)														
1	2	3	4	5	6	7	8	9	10	11	12	13	14	Total
<input checked="" type="checkbox"/> 3.7	3.2	<input checked="" type="checkbox"/> 2.3	<input checked="" type="checkbox"/> 2.2	<input checked="" type="checkbox"/> 2.1	1.7	<input checked="" type="checkbox"/> 1.5	<input checked="" type="checkbox"/> 1.2	<input checked="" type="checkbox"/> 0.8	0.7	<input checked="" type="checkbox"/> 0.7	<input checked="" type="checkbox"/> 0.6	<input checked="" type="checkbox"/> 0.5	<input checked="" type="checkbox"/> 0.5	14.6
-1.1	<input checked="" type="checkbox"/> -1.1	-0.8	-0.7	-0.7	<input checked="" type="checkbox"/> -0.4	-0.5	-0.2	-0.2	<input checked="" type="checkbox"/> 0	-0.1	-0.1	0	0	
?	?	?	?	?	?	?	?	?	?	?	?	?	?	
Analysis (See Analysis on Page 489)														
<input checked="" type="checkbox"/> A1	<input checked="" type="checkbox"/> A2	<input checked="" type="checkbox"/> A3	<input checked="" type="checkbox"/> A4	<input checked="" type="checkbox"/> A5	A6	A7	B1	B2	<input checked="" type="checkbox"/> B3	B4	B5	<input checked="" type="checkbox"/> B6	G1	
<input checked="" type="checkbox"/> C1	<input checked="" type="checkbox"/> C2	C3	<input checked="" type="checkbox"/> C4	<input checked="" type="checkbox"/> C5	<input checked="" type="checkbox"/> C6	<input checked="" type="checkbox"/> C7	D1	D2	<input checked="" type="checkbox"/> D3	<input checked="" type="checkbox"/> D4	D5	<input checked="" type="checkbox"/> D6	D7	<input checked="" type="checkbox"/> D8
E1	<input checked="" type="checkbox"/> E2	E3	<input checked="" type="checkbox"/> E4				<input checked="" type="checkbox"/> F1	<input checked="" type="checkbox"/> H1	<input checked="" type="checkbox"/> H2	H3	<input checked="" type="checkbox"/> H4	<input checked="" type="checkbox"/> H5	H6	
Types of Problems (See Analysis on Page 489)														
<input checked="" type="checkbox"/> Verbal Abuse	<input checked="" type="checkbox"/> Physical Abuse	Financial		<input checked="" type="checkbox"/> Psychological	<input checked="" type="checkbox"/> Shirinugui	Child-Related								
Note														

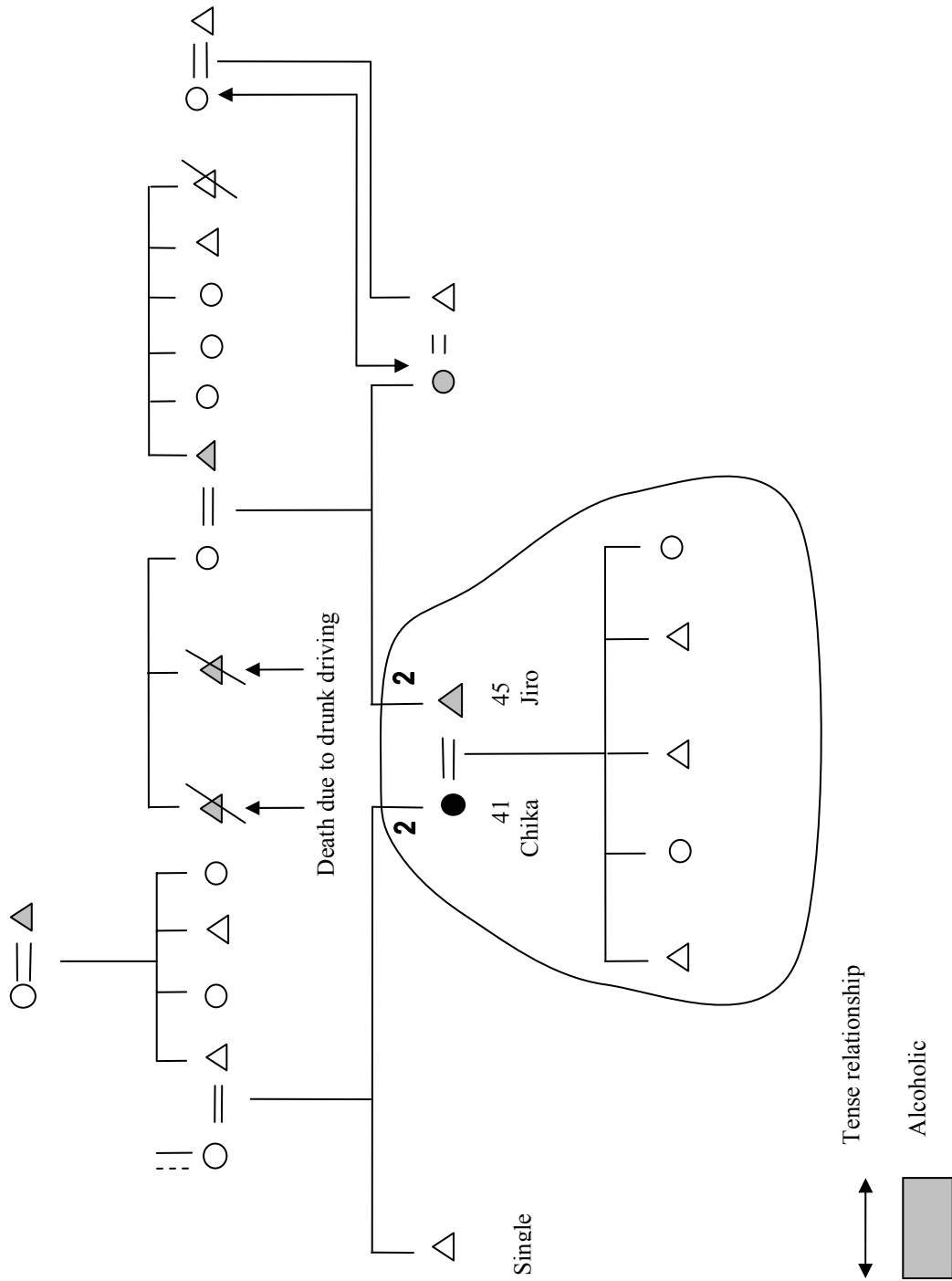

Chika Meguro

Chika is a charming mother with large clear eyes. She wears a salmon pink sweater with white pants. A cute stuffed animal (white rabbit) is attached to her waist which is her cell-phone case. These days, she seems to be busy with her Parents-Teacher Association (PTA) work since she is one of her children's PTA representatives [she does this every year]. "I couldn't decline [from becoming the representative]," she says.¹⁵

Husband's drinking habit before marriage

Chika married for love. Her friend introduced her to Jiro, and after a year of a relationship, they decided to marry. I asked about her views on Jiro's drinking habit before their marriage.

"He was already drinking a lot before our marriage. But at that time, I had a positive attitude towards men's drinking: 'strong against alcohol [a person who can drink without losing control] is a manly thing.'; 'a man who can drink is better than a man who can't drink.' There were times when I thought, 'drinking is bad' and 'I don't want him to drink anymore.' But this realization occurred after our engagement, when my parents and his

¹⁵ For non-Japanese readers: Although the title "PTA representative" sounds honorable, this position means "a person who is 'responsible' for doing miscellaneous tasks voluntarily for the children's school: organizing field trips, accompanying field trips, organizing school bazaar, collecting money for class events etc.' There is a small advantage of getting closer to the child's teacher. (But compared to the amount of work, this benefit is negligible.) In Japan, this position is often assigned to 1-3 mothers at the meeting on the first parents visiting day at school, every year. Most mothers are not fond of becoming a PTA representative. Many women are prepared with reasons for excusing themselves from the PTA tasks: "I have a job"; "I am busy taking care of grandmother" etc. And in this situation, it is often the naive house-wives who become PTA representatives.

parents were already on good terms with one another. In this situation, canceling our engagement was much more hassle for me than marrying him. I optimistically thought, ‘Oh well. It’ll be fine’ and married him.”

-----Could you tell me about the first time you thought that your husband is not a normal drinker?

“It was three years after we got married. I was 24 years old. My husband was doing *banshaku* [drinking with meal, see glossary on page 554] with my father. He was completely drunk and couldn’t talk properly.”

Recognizing husband's alcohol dependence problem

-----Could you tell me about your recognizing that your husband has alcohol dependence syndrome or is an alcoholic.

“I was 25 years old or so. I encountered a book written about alcohol dependence syndrome at the library. As I read it, I noticed that things written in the book resembled him and our family situation. Often, when we hear the word ‘alcoholic,’ we image a person with trembling hands and so on [Chika shook her hands and imitated the stereotypical alcoholic]. The book however explained that this is a false image of alcohol dependence syndrome. It also described about the ways how alcoholics involve family members, and his problem develops into a family problem.”

Considering her age of 41, one can assume that she has suffered from her husband's drinking problems for at least 16 years. Until today, Jiro still hasn't undergone any special medical treatment for alcoholism.

Chika has visited the public health center to consult about Jiro's drinking problems. However, she says, this was of no use. The officer at the health center told her about the Kurihama hospital [The national hospital in Kanagawa prefecture which specializes in alcohol treatment.] in Japan and that was all.

Husband's drinking habit

Chika's husband is 45 years old. He works for the sales division of an electric appliances company. He is an affable and a hardworking man.

-----In Japan, there are people who are assigned to the sale's division because they can maintain a solid character even though they drink a lot [i.e. useful for *settai*, a business related reception which often involves drinking]. Is this the case with your husband, too?

“He is friendly. He is also a reliable worker. But when it comes to drinking, his character changes and he behaves in a shameful manner. He never fights with important people such as his business partner, but he does pick a quarrel with other people, such as those who sit next to him at the bar. Wait, that's not correct... He has grabbed the branch manager by the collar...”

----- [He doesn't seem to apply to the ideal salesman type: the type who can operate drinking business without losing control.]

“So, all of his colleagues know that his drinking habit is bad. Considering this, he should be fired by now. I think the reason why he is still employed at the company despite his rude drunken behaviors is because he does a decent job at least during the working hours. [Chika paused.] There was one time he came home bloody. He had a fight with a man at the bar. According to my husband, the opponent was making a pass at a hostess who disliked his harassment. My husband told him to stop and pushed him, and then he was attacked back. In the end, Jiro lost and was severely injured. But since he was the one who started the fight, he didn't/couldn't call the police. He is sometimes impulsive and quarrelsome.”

Since Chika realized that her husband is an alcoholic, she has been trying to make Jiro not drink at home. Jiro, on the other hand, also drinks frequently outside because drinking at home is discouraged by the family. After drinking with his work-related people, he often drops by at a familiar bar alone and finishes the day with *shiage-zake* [finishing drink] before going home. Sometimes, when he has a quarrel at the bar, *Mama* [female manager of a bar, see glossary on page 556] brings him home. There are also times when *Mama* calls Chika and asks her to come to the bar to take her husband home.

There are times when a dead drunk Jiro returns home violently. When this happens, there is a tense atmosphere in the house; the children are frightened and hide in their rooms. In that situation, Jiro yells at Chika for hiding his children [the youngest child is still in kindergarten] from him.

“It’s he who is causing this because he yells. [Chika laughed.] But he doesn’t listen to me. He blames me for the children hiding from him.”

Cleaning up husband’s mess

-----Have you cleaned up your husband’s mess besides going to the bar to pick him up?

“One day, he got into a fight with the bar’s staff when he was drunk. On his way out, he kicked the bar’s automatic door and broke it. He couldn’t escape from it since the bar called the police. The next day, I went to the bar to pay for the damage. Jiro came along, but it was mainly me who apologized. Luckily, the insurance company paid most of the damage since we have an insurance that pays for such things. Well, honestly speaking, they are not supposed to pay for things that are damaged under the influence of alcohol, but, the officer of the insurance company was fortunately a very understanding man who kept our problem secret from the company. This is the reason why we got the money. Anyway, I was the one who wrote the difficult documents for this incident. A similar thing happened when he destroyed a hotel’s furniture, too. My husband has a bad habit of kicking things around him when sleeping. This time, while he was drunk, he unconsciously kicked and kicked the furniture located around his feet and destroyed it. It was again me who filled in the insurance company’s documents. I tried to make him do it, but he refused, saying that his handwriting was bad. The insurance company didn’t pay for the damage this time. So, for this incident, we paid 300,000 yen [\approx US\$ 2,727].”

Moderate drinking

Jiro is currently a “business bachelor” [living away from his family because of his job. See glossary on page 554] and has been for 2 and a half years in the countryside of Japan. He will start living together with his family again in half a year.

-----People say that the business bachelor situation increases the amount of alcohol men consume. Is your husband doing okay in this situation?

“He is a business bachelor per se, but he is living with his parents right now. He is also living in such a rural area that there is almost no place for him to drink outside of the house. Because of this, currently, he seems to drink twice per week at home. Every time he drinks, grandmother is accompanying him. Grandmother also struggled with her husband’s drinking [grandmother and grandfather are currently both participating in a self-help group]. So, in order to prevent Jiro from drinking too much, grandmother accompanies him while he is drinking. According to grandmother, Jiro is drinking with discipline: he stops when he has to. So for your question if he is okay as a business bachelor, I think he is fine.”

-----Doesn’t he drink outside at all?

“Well, in addition to living in a remote area, since he doesn’t behave well while drunk, many of his drinking friends left him. So, there is another reason why he doesn’t go out as he used to anymore. These days, he probably goes out once in two months.”

-----Before he started drinking in moderation, how much did he used to drink?

“Ten years ago, he was a *sake* drinker. He was drinking 5 *gou* [≈ 901 ml ≈ 0.23 US gallon] every day. No *kyukanbi* [day for resting one’s liver, see glossary on page 556] at all. It was common for him to become inarticulate. Sometimes he drank from 6 p.m. [after working hours] until past midnight. Sometimes while he was drinking at home, he was called by someone related to his work and had to leave to see them. In those situations, he met them while being under the influence. He has been criticized by his colleagues and customers several times that he smells of alcohol. These days, he is a *shochu* [distilled liquor, see glossary on p-557] drinker. He drinks only on Friday and Saturday. According to grandmother, half of the bottle is gone every time when he drinks.” [Chika gestures an 800-1000 ml bottle using her hands.]

-----Has your husband ever failed to keep an important promise or missed work because of a hangover [KAST question 7]?

“I would say ‘yes’ ten years ago. But ‘no’ now, since we learned from our experience; I don’t let him drink if there is something important coming up on the next day.”

Husband's drinking problems

Jiro heaps all sorts of verbal abuse on Chika when he is drunk. When I heard that he also physically abuses her [he once pointed a kitchen knife at her], I decided to perform a domestic violence screening test. While answering about the occurrence and non-

occurrence of various types of abuse [this involves non-physical abuse such as harangue and verbal threat as well as physical violence, such as punching and hitting], I also asked her to freely comment on my questions. When about half of the questions were finished, she tilted her head and looked as if she was dissatisfied with my questions and said:

“This isn’t grasping the whole picture... Yes, he does harangue me, yell at me, and physically abuse me when he is drunk. But...but...this is not exactly right. You are not grasping the right picture.”

-----What do you mean? [Is she unsatisfied with the structured questionnaire which makes her feel as a mere victim?]

“For example, my husband has a desire to commit suicide. He sometimes tries to fall down from a veranda or holds a kitchen knife to kill himself. When this happens, I try to stop him. And the extension of this is what I have answered, where I get abused by him verbally and physically. In addition, [Chika looked hesitant.]it’s all my fault.”

Chika’s religion; explanation of husband's drinking

-----What do you mean?

Chika looked as if she was pondering something.

“For you to understand, you need to know about my religious belief.”

-----Could you explain it to me?

“Before knowing about 'The Righteousness of the Family' [pseudo-name of a religious organization], I used to blame my husband for all the things he did. Sometimes I accused him and was pushing him into a corner. As I learned about this religion, however, I realized that the reason why these things happen is not because of him, but because of the sins I committed in my previous life. My present situation is predestined from my former life. Things you have done carry over in an opposite form into your next life. My current situation means that I have done something wrong in my previous life. It is important that I make up for this in my present life because not doing so means the problem will remain and will carry over into my next life. [Chika smiled uncomfortably.]”

This religion—The Righteousness of the Family—originates from the *Hokke* sect of Buddhism [it emphasizes the importance of chanting, which grants one’s peaceful death and brings the world of paradise in the present world] which emerged during the active religious movement period of the Japanese Kamakura era [A.D.1192-1333]. 'The Righteousness of the Family' believes that reading the mantra will atone for one’s misdeeds and also corrects the present life into a good direction simultaneously. This religion also puts significant importance in worshipping one’s ancestors since the soul reincarnates through one’s lineage. Chika has been a follower of this religion for approximately 10 years.

Chika thinks that her devotion to this religion spurs Jiro’s abusive behavior against her.

“His ill talking while drunk worsened since I entered this religion. He doesn’t like me getting involved with this religion, at all. Every time when he drinks, he puts down my religion. [Chika paused.] One day, he hit me so severely that I bled. This incident is also related to my religion. Usually he hits me with an open hand; but this time he knocked me with a fist [Chika made a fist with her hand]. This happened because I increased the level for my religious training. Until then, although he spoke ill of my religion, he had never dishonored the *gohonzon* [sculpture of Buddha], but on that occasion, he took the *gohonzon* from the altar and tried to throw it away saying ‘This is nothing!’ With all my strength, I crushed into him on the floor to rescue the *gohonzon* from him. Then Jiro punched my eye [Chika pointed the area between her eye and her eyebrow.] and it started to bleed. My children were shocked when they saw me bleeding. We thought of calling the police, but we didn’t after all. Jiro took the children to their bedrooms and put them to sleep. Although it appeared as if the whole thing had ended, he came back and scolded me endlessly throughout the night. Thinking about it now, there was bad on my side as well; I might have had an arrogant attitude -- I will save him -- which might have offended him.”

Jiro’s violence worsens as Chika’s faith deepens. For Chika this violence appears as an obstacle of following her religious belief. She believes that Jiro’s behavior is due to him being possessed by hostile souls inflicted by her sins committed during her previous lives. These suffering souls, by attacking her, lessen their own gloom.

“This is my fate. It is predestined from my previous life. Jiro doesn’t know such things, but the souls know and influence him. I consider the present situation as ‘the training I must go through’ or ‘an opportunity to train myself.’ It is extremely difficult to get rid of the hostile souls which developed over thousands of years. But if you try hard, it is possible to direct one’s soul in a good direction.”

Purification of the soul is done through chanting the mantra. Chika reads the mantra every day, in the morning and in the evening. She is accustomed to the chanting, which took her an hour in the past, only taking 30 minutes these days. Sometimes, because of the chanting, however, she still gets behind schedule, such as being late for preparation of meals and other important tasks.

“It’s my fault. If I am strict enough to myself, such things should not happen. It’s all because of my weakness.”

Chika always blames herself.

The reason for becoming a follower of the religion

Chika joined 'The Righteousness of the Family' about ten years ago. This coincides with the period when Jiro’s drinking problem was severe, which led to him starting to follow the moderate drinking policy.

-----Why did you become a member of this religion? Did you join the organization because your suffering feelings caused by Jiro's drinking were properly treated by this organization?

“No. Before knowing about this religion, I used to have the *mizuko* [aborted fetus] problem. I wanted to atone for my sins and hold memorial services for *mizukos* at that time. Then I came across this religion. Through their religious belief, I learned that what I have done [=aborting the children] was a terrible thing; It means that my *mizukos* had to go through a horrible experience in the spiritual world. This made sense in relation to my husband's drinking problem which I was experiencing at that time. But this is something I realized later when I learned more about this religion. Therefore, Jiro's drinking problem is not the direct cause of entering this religion.”

She aborted two fetuses. The first one was created before their marriage. Although it was a pregnancy after their engagement for marriage, it was aborted because Jiro worried about his reputation. The second one was aborted since Chika suffered from German measles during her pregnancy, which has a significant chance of causing a disabled child. Although the second abortion was unavoidable, she seems to carry resentment with her husband who was unconcerned and ambiguous about their problem: “Either way [aborting or not] is fine,” he had told her.

After joining the religious group

Before entering the religious group, Chika frequently used to experience *kanashibari* [a physical state where one cannot control one's body and feels controlled by something else, i.e. by a supernatural being. In Japan, people who experience *kanashibari* are often believed to have supernatural powers, such as being able to see or communicate with supernatural beings.] And during that time, she always noticed a boy going up the stairs in the house. Since she joined her religion, she no longer notices the boy in the house. [She still experiences *kanashibari*, though.] Moreover, since she entered the 'The Righteousness of the Family,' Jiro decreased the amount of alcohol he drinks every day. Often when Jiro becomes violent, Chika starts chanting the mantra. When she does this, Jiro stops abusing her and falls asleep.

"If I was not following this religion, I believe Jiro would be dead by now." She then expresses her strong will of continuing this religion: "I will carry on my religious training no matter what, even if it leads me to be killed by my husband."

Our world needs to be purified

Chika is considerably knowledgeable about her religion. She told me about the religion's history, size, doctrine, fairness [no expensive obligations, as seen in many other religions], teachings such as the difference between *jishi* [mercy] and *ai* [love], and some miracles that happened to her. Her perspective on the recent cruel incidents that happened in Japan [e.g. a mad man murdering 14 children with a knife indiscriminately at a schoolyard] was unique to her belief.

“In this incident, too. I see the evil spirits controlling him. Therefore, he lacks the sense how to distinguish good from bad...”

According to Chika, the world is moving the wrong way. It has been worsening especially since the year 1937 [This was the beginning of the fanatic period which led to Japan fighting in the Pacific War.] when the *maaku-no-kama* [the pot of the evil] was opened.

“The world is filled with evil spirits. It is very difficult to be freed from them because it means that you are purifying these souls which developed in no less than 10,000 years. But while we are alive, it is possible to make at least a small difference to these souls. What we have to do is to properly compensate these souls and ask for forgiveness. [Purifying the souls is possible through worshipping one’s ancestors and reading the mantra.] If people ignore their obligations and live their lives selfishly, the souls will increase their hatred and our world worsens.”

Religion and husband’s drinking

While Chika’s explanation for Jiro’s drinking is religious [a belief based on fate from the previous lives], Jiro’s explanation for his problem is due to Chika’s devotion to her religion.

-----Do you think then that your husband’s violence will really stop if you disengage yourself from this religion?

She answered with a determined tone: “No. I don’t think the problem will diminish. [That is because Jiro trying to stop her devotion to the religion is the force of the evil spirits trying to prevent her from living in the right way.]”

Reasons for husband's drinking

Chika explains the cause of Jiro’s drinking from her religious perspective. It is obvious that this view is everything – the “truth” from her perspective. While I understood her religious recognition of Jiro’s alcohol problem, I also became curious about the way she perceives the problem *besides* her religious views.

-----I have learned about your religious views on your husband’s problems. Are there any other reasons besides this religious view which you think may be a reason of his drinking?

“Ten years ago, before knowing about this religion, I used think that he is lonely. In addition, he is only a high-school graduate. Since people with a university degree are more likely to get promoted in our society, he is behind on the promotion ladder compared to other colleagues of his age. I used to think that this situation might be causing stress in him.”

Family background

Since nothing had been mentioned about Chika or her husband’s childhood circumstances as being the root of their current problem, I asked Chika about her and Jiro’s family

background. Chika was brought up in a family where people hardly drink alcohol. Her grandfather [Chika's father's father], however, was a drinker which his wife [Chika's grandmother] disliked. Chika's mother is an adopted daughter in a family that had only sons. Chika's older brother is still single.

On the other hand, there are many drinkers in Jiro's lineage. His older sister is a heavy drinker. As described earlier, Jiro's father is an alcoholic and currently participating in a self-help group together with his wife. Also Jiro's mother's two brothers died due to traffic accidents while they were under the influence. I asked if Chika has heard the saying, "an alcoholic is alcoholic because he is from the lineage which [can] drink" or "an alcoholic is alcoholic because his family is alcoholic," and if she thinks these sayings apply to her husband. She agreed, but, moreover, she seemed to believe that these commonly observed situations are due to the fates of alcoholic families, which are all related to souls hostile to their lineages.

Mother-in-law problem

There have been cases when the husband's drinking was caused by the hostile relationship between his wife and her mother-in-law. I asked about the possibility of this being the case for Chika. From her remarks, the wife and mother-in-law problem does not exist. First of all, she is not living with her mother-in-law. Rather, she says that her mother-in-law is her best consultant regarding her husband's drinking.

“Since my mother-in-law also suffered with my father-in-law’s drinking problem, she listens to my problems with sympathy. I know she understands me from her heart. Her support is very important to me.”

As described earlier, Jiro’s mother accompanies Jiro when he goes drinking and also reports to Chika about the way Jiro drinks. Jiro’s mother-in-law is also understanding to Chika’s religion such as by decorating her family altar with the religious goods Chika gave her. Also, since Chika’s own parents are strict and in general do not listen to their children’s complaints, Chika does not consult her own parents about Jiro’s drinking and violence at all.

Chika’s wish

-----Please tell me if there is any wish concerning your husband’s drinking.

“My true wish has always been that he will not drink.”

----- Is there any action from social services you would like to receive, or something you wish to happen in our society?

“In TV shows, there are often situations where people talk funny and proudly about the drinking problems they caused and experienced. I really don’t like that. I want the media to report the right thing. And also in those shows, there is this message of...oh how can I say

[Chika behaved as if she is having difficulty explaining] ‘drinking a lot is something good to do’ or ‘people are supposed to drink and get drunk’ in these shows.”

-----Are you saying that they are conveying the message of *kanyou na inshubunka* [permissive drinking culture]?

“Yes, that’s it! I think that culture is very misleading.”

Chika’s present tasks

Although Chika suffer from Jiro’s abuse, she is never helpless. She always makes an effort to overcome the situation. These days, she is learning the principles of creating her religious posthumous names. For this, she learns, for example, the ways of making names by compensating something the dead lacked in his/her present life with a Chinese character [concept]. According to Chika, everything is heading in the right direction.

“Jiro often says, ‘Whatever I [=Jiro] say, whatever I do, everything at the end is working in the way you [=Chika] want.’ [Chika laughed]”

Chika has a strong faith and it is supported through her daily religious exercise. Her faith is certainly the source of her strength.

Case 5. Triangular relations between husband, son and me (wife)

Name				Age		Occupation									
Shizuyo Matsuda				63		Accountant at a hospital (part-time)									
Family						Husband's Occupation									
<input checked="" type="checkbox"/> Nuclear		Extended		# of members		4		Manager and owner of music store							
Family members															
Shiro		Husband		65											
Shizuyo		Wife		63											
Kazuo		First son		38											
Tsugio		Second son		36											
Total Interview Time				Ex-husband Attending Self-help Group?				Wife Attending Self-help Group?							
First: 4 hour 20 minutes Second: 2 hours				?				<input checked="" type="checkbox"/> Yes No							
Wife's KAST concerning her husband's alcohol related behavior (See Appendix 1 on Page 546)															
1	2	3	4	5	6	7	8	9	10	11	12	13	14	Total	
<input checked="" type="checkbox"/> 3.7	3.2	2.3	2.2	2.1	1.7	1.5	<input checked="" type="checkbox"/> 1.2	0.8	0.7	0.7	0.6	0.5	0.5		
-1.1	-1.1	-0.8	-0.7	-0.7	-0.4	-0.5	-0.2	-0.2	0	-0.1	-0.1	0	0		
?	?	?	?	?	?	?	?	?	?	?	?	?	?		
Analysis (See Analysis on Page 489)															
<input checked="" type="checkbox"/> A1	<input checked="" type="checkbox"/> A2	A3	A4	<input checked="" type="checkbox"/> A5	<input checked="" type="checkbox"/> A6	<input checked="" type="checkbox"/> A7	B1	B2	<input checked="" type="checkbox"/> B3	B4	B5	B6	G1		
<input checked="" type="checkbox"/> C1	<input checked="" type="checkbox"/> C2	C3	C4	<input checked="" type="checkbox"/> C5	<input checked="" type="checkbox"/> C6	<input checked="" type="checkbox"/> C7	D1	D2	<input checked="" type="checkbox"/> D3	D4	D5	D6	D7	D8	
<input checked="" type="checkbox"/> E1	E2	E3	<input checked="" type="checkbox"/> E4				F1	<input checked="" type="checkbox"/> H1 <input checked="" type="checkbox"/> H2		H3	<input checked="" type="checkbox"/> H4	<input checked="" type="checkbox"/> H5	<input checked="" type="checkbox"/> H6		
Types of Problems (See Analysis on Page 546)															
<input checked="" type="checkbox"/> Verbal Abuse		<input checked="" type="checkbox"/> Physical Abuse		Financial		<input checked="" type="checkbox"/> Psychological		<input checked="" type="checkbox"/> Shirinugui		<input checked="" type="checkbox"/> Child-Related					
Note															
Marriage Status: Divorced															

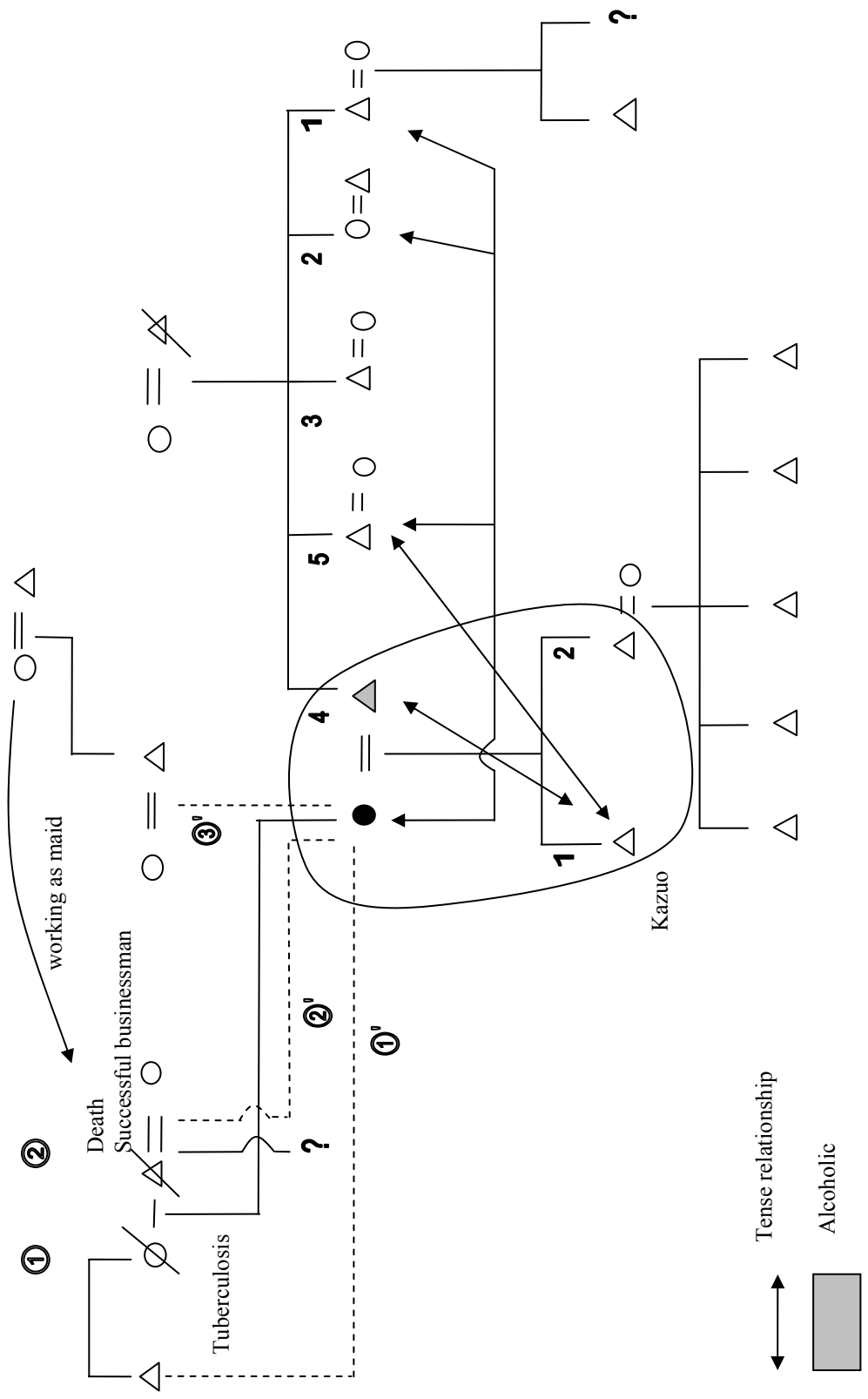

Shizuyo Matsuda

Shizuyo is short, skinny, cheerful and frank person. Throughout the interview, she talked with rich expressions on her face. They were mostly positive expressions [e.g. laughing, smiling, joking tone] despite the depressing story she told.

Family background

Shizuyo's family structure is complicated.

“I must start my story from here. You see, I don't have parents....”

According to Shizuyo, her parents were not married to each other. Her biological father was a successful manager of a big company who was married to another woman, not Shizuyo's biological mother. Since her biological mother died early from tuberculosis, Shizuyo was taken in by her uncle, her biological mother's brother. That was before WWII when most Japanese were poor; life for her uncle's family was not easy either. Shizuyo's uncle asked Shizuyo's biological father for money in the name of taking care of Shizuyo. Her biological father could not tolerate this and therefore decided to take her in himself and live together as a family. This, however, did not last long. Her biological father died. She was then adopted by the son of the maid working at her biological father's house. After this adoption, the maid's family immigrated to Manchuria where nobody knew about Shizuyo's family history. Unfortunately, Japan lost WWII and Shizuyo's new family had to go back to Japan.

Later, Shizuyo married Shiro in an arranged marriage which ended up in divorce. Her record in the family register is, in her own words, “*guchagucha* [very messy]”; in

addition to the frequent adoptions, her aunts and uncles sometimes suddenly temporarily become her parents for some urgent reasons.

“I sometimes think that the root of all the problems I confronted is perhaps found in this complicated family situation. One doctor once told me that I may have *misuterare-fuan* [fear of abandonment] problem.”

Husband’s violence to Shizuyo

“From the part of their marriage, Shiro, my husband, drank and criticized me and held lengthy sermons every evening. He often said that I was useless. He especially criticized me about my cooking skills. I couldn’t prepare traditional dishes like *kinpira* [black-root and carrot stir-fry] or *nikujaga* [potato and beef stew] well. So, considering food, I was often accused of my lack of skill: ‘You can make only this?!’ or ‘You are the worst!’ I felt upset when he said that, but since I was afraid of him attacking me further¹⁶, I never accused back but always passively accepted his attacks.”

-----Was there any physical violence against you?

“Well, not really. [Shizuyo seemed to be thinking.] Well...I remember he poured water from a kettle...”

¹⁶ Note that Shizuyo is a short and skinny person.

As our conversation went on, I learned her ex-husband had been physically abusive. Shizuyo told me that she was often cautious about his feelings. When he was in a bad mood, she was restlessly worried about what might go wrong next. When he was angry, he overturned the table and hit or kicked the furniture. He dragged Shizuyo and took her outside. One cold winter day, she was freezing badly since he had poured water over her head.¹⁷ Unexpectedly, she covered up for Shiro for this incident:

“Well it wasn’t that bad. He saw me trembling and was kind enough to turn on the hot water at the bathtub for me.”

Husband’s violence against his son

It seems, however, Shizuyo’s great worry was not the bad relationship between her husband and herself, but the violent relationship between her husband and their first son. The relationship between these two has been a vicious and lengthy tit-for tat, neither one being willing to give in.

Shizuyo’s husband was originally working for a company that sells musical instruments. But since the company went bankrupt, he started a similar business of his own.

“You see, having your own business is tough since it requires a great deal of responsibility. I think it is the stress induced from his work which led him to drink so much.”

¹⁷ It is unclear whether this incident of pouring water over her head is the same as the one mentioned earlier.

When he drank, he took it out on the other family members, especially Shizuyo and their oldest son. He sometimes flew into a rage over trivial things, such as at the oldest son's angry look towards his unreasonable father. In the past, when a quarrel occurred, Shizuyo was often passive; she simply did not know what to do. The oldest son grew up in this environment. He was abused by his father and not supported by the passive mother. Kazuo [first son's name] blames his mother, Shizuyo, for not rescuing him when he was beaten by his father.

“Kazuo accuses me, saying things like: ‘You did not protect me’; ‘You did not help me’; ‘You left me alone.’ Although I was hurt inside, I didn’t have the ability to carry out any action.”

Going through the ninth grade's high-school examination period in such a family environment disturbed the first son's life greatly. According to Shizuyo, while denying his own problem, Shiro was strict with his first son: “You must pass the exam for Kita high school! I am not going to pay for any other options!”¹⁸ The son took his words seriously and took the exam for Kita high school without any safety measures against failure, and failed. The only available option was to take the exam for Minami high school, the only school where the exam registration deadline had not yet passed. Kazuo's ability was much higher than required to pass the Minami high school entrance examination. Nowadays, Kazuo recalls this time and expressed his complicated feelings to his mother, “There was a

¹⁸ In Japan, people commonly take several entrance exams as a safety measure against failure at the desired school. How many exams one can take depends on the schedules of the different entrance examinations.

feeling in me [=Kazuo] which desired to fail the Kita high school's entrance exam. I wanted to cause trouble to dad." For this matter, Kazuo often expresses his regret for not giving up the orthodox road of life—go to high school then college/university and work as a white-collar worker—at this point and rather pursuing the skills required as a specialized worker such as an artisan, chef etc. Unfortunately, Kazuo did not spend pleasant years at Minami high school. He was the target of bullying at that school.

"There, Kazuo was treated such that his dignity as a human being was denied. He never tells me how he was bullied. He once told me, 'I will never ever—even when I die—tell you how I was treated at that time.'"

-----So he quit school?

"No, the one who quit school is my second son. From junior high school on, he was bad, participating in *bousouzoku* [motorcycle gang] and so forth. He quit high school. He married at the age of 18, and is now living with his wife and five children. He is like *yakuza* [Japanese mafia].... He is not *yakuza* officially, but what he is doing is not much different from *yakuza*. [Shizuyo paused.] But although he has a troublesome character, he is strong, and has the survival skills to live independently. He owns several bars and shops, for example."

The story's topic goes back to the oldest son.

“The oldest son graduated from high school. Although he wanted go against his father’s will and quit school, he was also very scared of him, thinking ‘Dad will kill me if I do that.’ Kazuo once told me, ‘Being the target of bullying was still more tolerable than the treatment from dad.’”

The oldest son perhaps did not want to end up with only ‘Minami high school graduate’ in his resume; he passed the entrance exam for a university through the recommendation of Minami high school.

“But he only attended the entrance ceremony of the school and quit the next day. According to him, he did not want to live in the way his father wanted. Since we paid the expensive entrance fees for the university, of course, my husband was furious when his son quit the university after a single day.”

The oldest son’s violent behavior

Shizuyo’s oldest son was originally not a violent person. He was rather a passive type, letting his father do whatever he wanted. This pattern however changed when Kazuo became a high school student; he started to use violence, too. The violence level of fights between Kazuo and his father increased: sometimes one of them held a bat in his hand and chased after the other one who was holding a butcher-knife. Occasionally, Kazuo’s friends or his soccer coach came to Shizuyo’s house and persuaded them to stop the fight.

Shizuyo’s husband’s attitude changed 180 degrees and he became polite whenever an

outsider intervened; but as soon as the guest left the house, his madness returned and the fight continued.

Moving out and the worsening of Kazuo's violence

Shizuyo consulted many people surrounding her about the intra-family violence problem.

One day when she was talking at the barber shop, one staff said to her, "Perhaps your husband has an alcoholism problem." This suggestion made her recognize the problem.

After this, she consulted specialists engaged in such problems. A psychiatrist told her, "Your husband has an alcohol problem." A staff member at a mental health hospital told her, "Your husband has alcohol dependence syndrome. Your son is a victim of such a problem." Some suggested, "Those two should be separated. If you let it go on like this, one of them may get killed." With these suggestions, the family decided to separate the two after all. Shizuyo decided to live together with her first son, Kazuo, who moved out from the house. While living in an apartment, she went to her husband's house and took care of his domestic tasks, such as cooking, cleaning, laundry etc. This, however, did not solve the problem. Kazuo now became violent towards her.

"His violence against me was not violent violence [intense physical violence]. Well, but...he poured a kettle of water over my head when I was sleeping. It was the same as what his father had done. One day, I found my handbag violently marked with red permanent marker. There was my favorite book torn into pieces, too. Oh yes, there were also my clothes being burnt, too."

She then consulted people about her son's problems.

“[For my son's violence problem,] I consulted various people. Among them, several specialists connected our situation with the famous ‘metal-baseball-bat incident’, saying things like ‘If you let the problem continue, it will end up in a metal-baseball-bat incident.’”¹⁹ [Shizuyo considers such advice from specialists rash. This topic will be described later.] “In those days, the specialists with whom people could consult about such problems were called ‘*shidouin* [person who gives guidance]’ instead of ‘*kesuwaka* [case-worker].’ Anyway, that aside, I consulted a *shidouin* whose advice was: ‘the problem is in the environment where you go back and forth between your son and your husband's place all the time. You should completely get out of your husband's house and live your life distant from him.’”

After a lot of thinking, Shizuyo decided to live separately from her son. During the daytime, she went out by bicycle and secretly looked around the neighborhood for a possible apartment. Once determined, she started preparing to move out from the apartment again, little by little. And finally, one day, she left the house without any notice left for the son.

“I actually did this for the sake of Kazuo's independence. But I think it was a wrong thing to do after all. The oldest son was furious. He accused me saying, ‘You abandoned me!’ ‘I

¹⁹ A series of murders occurred in Japan in the late 70s and 80s where either the parent(s) or the child used a metal baseball bat to kill the other. It was pointed out that these incidents occurred among the so-called "intellectual elite."

have been taking care of you a lot, but you left me without saying anything...From now on, I am not going to do anything for you! Your problem is your problem. Take care of it by yourself. I have absolutely nothing to do with it!’ He said all this without even looking at my face. He was an adult, a man with a beard, but he was not grown up at all. At that time, he appeared to me as a three or four year old boy, really.”

Decision to divorce Shiro [first time]

Around that time, Shizuyo asked Shiro [her ex-husband] to get divorced, but he did not grant this request.

“Perhaps, nothing is more humiliating than being asked to get divorced.”

She therefore appealed to the court. In addition to officially divorcing Shiro, she demanded the house he was living in and three million yen as a compensation fee. [US\$27,273. Shizuyo says the amount was determined by the lawyer at her discretion. Shizuyo is dissatisfied with this procedure.] The lawyer was a woman recommended by the staff working at a hospital specializing in alcohol treatment.

“Until then, I didn’t know that at these trials one must cry with lots of tears. During and after the trial, I was often taken to another room by the lawyer and was told ‘You must express your emotion more!’ In fact, instead of saying ‘being told,’ it is more proper to say that ‘she was angry at me’ or ‘I was scolded by her.’ I was offended every time this happened. I remember I was always crying on my way back home from court.”

Shizuyo won the trial. At that time, a divorce granted through trial had to be documented within two weeks of the last court date. Shizuyo called her second son at once to make arrangements saying that Shiro [ex-husband] had to get out from the house immediately. The second son replied:

“House? Three million yen? What are you dreaming, mom? Father’s business went bankrupt; you may incur the burden of debt, too.”

Shiro had been swindled by a fraud. His life was quite messy at that time because of the bankruptcy and his worsened drinking. Shizuyo was surprised and explained about the situation to her lawyer. The lawyer however treated her coldly. Shizuyo was told, “Your primary wish was to divorce him. You accomplished this goal. What else would you ask?” and at last “I am too busy to meet you. [I don’t want to be involved in your problem any more.]” Shizuyo was in trouble. She thought long about what to do. And her final perception was: “It’s not Shiro himself that I dislike. What I really don’t like is the alcohol that he drinks.” So, she decided to go back home. At that time, Shiro and his sons welcomed her back. For a while after that, Shizuyo and her family were busy trying to repair the disastrous situation. Shiro started abstaining and Kazuo came back home and helped his father out. There were occasional fights between Shiro and Kazuo. Kazuo was especially discontent with his father telling people that the bankrupt was not his fault but rather due to his first son. Although these fights occurred sometimes, it was a relatively

peaceful time for the family. However, the pleasant time unfortunately did not last long. Shiro started drinking again.

Hospitalization

Shiro's alcohol dependence worsened. It went to an extent that he could not eat food anymore. In the living room, he lay on his futon bed and stayed there all the time. Since Shizuyo and Kazuo did not want Shiro to occupy the living room all by himself, they insisted to eat their meals in the living room, too. They later gave up the living room though; the room started to stink because of Shiro's drinks and various other nasty things.

“At that time, Kazuo was taking his revenge on his father who was incapable of eating. Well, here is the story. One day, a long time ago, Shiro's brother and his family visited our house and we ordered a sushi delivery. Kazuo ate the dish as well, but Shiro didn't like this. Immediately after the visitors left, Shiro furiously scolded Kazuo saying, ‘Who told you to eat the sushi! Spew out!’ Now, the time had come for Kazuo to bully Shiro, in turn. While Shiro, who was unable to eat, was wrapped in his futon, Kazuo purposefully made loud noise while eating and said loudly, ‘God dammit! This sushi is amazingly good. Ohhhh, this is extraordinary! [Shizuyo imitated the son's intentional chewing sounds.] Ohhhh delicious! [chewing sounds again] Emmmm yummy!’ [Shizuyo laughed.] Honestly speaking, I though this was cruel to Shiro. But, hey, he's the one who started it; perhaps he deserved it.”

Shiro's health was extremely bad. Seeing her unsteadily walking husband, Shizuyo said that anger welled up in her instead of sadness or pity.

“Shiro asked me to call the ambulance and take him to the hospital. I denied saying, ‘It’s your problem. Please do it by yourself.’ My feeling was, ‘Well, if he dies, then, too bad for him!’ [Shizuyo laughed.] In the end, the second son carried Shiro on his back and took him to the hospital. He was hospitalized for three months.”

At the end of his hospitalization, Shiro consulted his second son about whether he should go into an institution that has the right facilities for him [nursing home or place with maid service]. Considering the financial situation, however, the second son decided to take him to his own home. At that time, the second son, who was better at controlling his troublesome father than his older brother, was living in a small apartment with his wife and five children. The second son then suggested swapping their apartment with the house where Shiro, Shizuyo and Kazuo were living at that time [This means that Shizuyo and Kazuo were to live in the second son's apartment, and the second son's family and Shiro were to live in the house.]. After this decision was made, the moving effort started.

However, on the evening of the day the moving was completed, Kazuo drank excessively and started questioning the validity of this move. He complained about the situation loudly, “Is this really the right thing to do for dad? Is this the way it is supposed to be for him?”

While describing Shiro's trembling hands and his memories about him from his youth, the first son burst into tears and cried and cried: “[The first son talking:] This move is something you guys decided, not me. Why can't we let dad live here in our house? Why

not? Well, I decided to go to the hospital tomorrow and tell dad about my suggestion.”

While uttering such things, the first son was worrying about Shiro a lot. This behavior was not understandable to Shizuyo. She said:

“Well, there were times when Kazuo was indeed loved and taken care of by Shiro. Perhaps there is a strong bond between father and son which is impossible to break.”

Since this happened right after they finished the move, the second son got angry with the sudden suggestion to change the plan. He accused his big brother saying, “Kazuo is worried about the house being taken away by me.” Shizuyo does not know the real cause of Kazuo’s peculiar behavior and she never will. The discussion continued for a long time that night. At the very end, it was concluded by the sons, Kazuo and Jiro, with the idea that “All these problems are because of mom, who is bad.”

Suicide

“When I heard this, I really thought of killing myself for them. Why do I have to be blamed by both of them? We were staying at the second son’s apartment at that time. I even thought of jumping off the balcony which just might have been enough to kill me.”

Eternal triangular relations

Shizuyo summarized her stories from her perspective.

“One day, Kazuo [first son] said to me. ‘I was probably homesick. Although dad and I blame each other and I hate this so much, I can’t live without these continuous rages on the other hand.’ I thought this concisely tells many things about our family. The two—Kazuo and Shiro—argued with one another all the time. Even those were deadly painful experiences, they still argued, collided against one another, and hurt each other physically and mentally. Although these are destructive experiences, they function as they are keeping some sort of balance in our lives. Perhaps we can’t live without them since the constant fights are part of our lives. And these are triangular relations. There are Shiro and Kazuo, and then me. [I was thinking, ‘Not Shiro and Shizuyo, and then Kazuo?'] Everything comes down to ‘*kazoku kankei byo* [the disease of family relations]. Yes, that is what we suffer from.”

Husband

-----What kind of person is your ex-husband?

“He looks like a very kind man. From his appearance, he already looks kind. Smiling and being polite.... When he meets his friends or even my friends, he purposefully stops his car and greets them. Many people surrounding me have said, ‘Your husband looks like a kind and a wonderful man.’ When I was to get married to him, since I didn’t have parents, I asked my best friend to see him objectively and tell me if he is okay to become my husband. She examined him and said ‘Shizuyo, he looks like a very good person! It seems like he is crazy about you, too! Good for you!’ See, he is very good at giving a good impression to

others. Therefore, some people even say that ‘all the reasons that made him the way he became are in me, not him.’”

-----How do Shiro’s siblings see him? Is he a problematic person to them at all?

“Shiro is respected and adored by his siblings. They think he is a ‘dependable brother’ for them.”

-----But don’t they know that Shiro is problematic drinker?

“Yes. But... I think they believe that ‘It is Shizuyo who spoiled Shiro who then became a rotten and irresponsible man.’”

Desire to be understood

-----How do you think about the long period of agony now?

“Well, I can’t help it. It is something that happened in the past. There is no way we can change it anymore. I am sorry for my children who blame me for my wrongdoings. But you see, I consider their complaints in this way: ‘They are accusing me since I am at least sane enough for them to complain about their problems [Shiro lacks this sanity.]’; ‘I should therefore rather appreciate the situation of receiving complaints and not being totally ignored and neglected.’ and ‘Perhaps this is the way it should be.’ I try not to say excuses. Honestly speaking, of course I want to say back ‘Well, for that matter, there was this factor

and that factor which was unavoidable...’ But, this is what I try to avoid. I just say ‘I’m sorry. It was my fault.’ You might find this very Japanese, but there is a feeling in me that I want them to understand my feelings. But...probably, that will not happen in my lifetime. [Shizuyo smiled sadly.]”

Advice

-----Do you have any advice to women who suffer from problems similar to yours?

“I think it is important that you are informed about the nature of alcohol dependence syndrome. Many people are ignorant about this problem and therefore simply give in and endure the devastating situation. Well, that is the wrong thing to do. Knowledge about the problem will prevent further damage in many ways. These days, contrary to the way things were in the past, there are many self-help groups operating in this region. You can go to those meetings, such as AA, and learn about it. I know that some lawyers and doctors give public lectures about things related to this problem. There are many articles written about alcohol these days, too. By whatever means, it is important that you seek this kind of information and become knowledgeable.”

She mentioned TV dramas.

“These days, there are popular dramas that portray the problems in our society, such as problems of *hikikomori* [shut oneself away from society, see glossary on page 555], child abuse, AIDS, etc. However, I have never encountered a popular drama about alcohol

dependence syndrome. I think the influence of TV is strong. Aren't there many dramas like that in the U.S.? [Shizuyo asked me.] I think it would be good if there was a good movie or drama about alcohol dependence syndrome, like, for instance, the alcoholic ending up dying alone. Such things can make a big impact in the society, which brings more awareness about alcohol dependence syndrome in our society."

Shizuyo also talked about the problematic aspects seen among the alcohol-related specialists such as doctors, counselors, lawyers, etc.

"I was often told by specialists engaged in these problems, 'If you leave it like this, it will end up as a metal-baseball-bat incident.' I doubt their logic of directly connecting the child's domestic violence to the metal-baseball-bat incident. I say this since there was a part of me that was influenced by these specialists' words and I became hasty. You see, I don't think the situation 'kill-or-be-killed' happens that easily. There are various cases; things can change significantly based on the personality of the people involved."

She also mentioned about the problems of 'enablers [see glossary on page 555].'

"Since I work at a hospital as an accountant right now, I encounter many patients with alcohol dependence syndrome. There are often cases where an alcoholic is brought by his family members. In these situations, the alcoholic is told by others like his wife in a gentle but also desperate tone: 'Oh, please father. We have come this far to see the doctor. Let's wait just a little more to see the doctor, please.'; 'Please please accept the doctor's

suggestion and be hospitalized.’ When I see these wives, I become very angry about their behavior. It makes me think, ‘It’s you who is taking care of him unnecessarily and making his situation worse!’ When I see this, it makes me sick. I feel like slapping them several times. [Shizuyo gestures slapping someone’s cheek several times.]”

She related her stories with much laughing and smiling from the beginning to the end, despite the fact that the story was of continuous struggle, one after another.

Note:

After a period of separation Shizuyo officially divorced Shiro. Her life as an accountant at a hospital [part-time] is not easy, but she appreciates her luck of obtaining this position in her late 50s. She is currently an active member of a self-help group. She does not know where her ex-husband lives and what he is doing right now. It appeared to me that he is no longer of concern to her.

Case 6. Life has gone through the bottom several times...

Name					Age		Occupation								
Tomoko Nitta					45		Flower shop (part-time, currently unemployed)								
Family							Husband's Occupation								
<input checked="" type="checkbox"/> Nuclear			Extended		# of members		4		Operator of machines at food factory						
Family members															
Matsuro		Husband			43		Diagnosed with alcohol dependence syndrome and mania-depression								
Tomoko		Wife			45										
Kazuo		First son			23										
Kazuko		First daughter			21		Hikikomori [Shut oneself in from society, see glossary on page 546]								
Total Interview Time				Tomoko Attending Self-help Group?				Ex-Husband Attending Self-help Group?							
3 hour 20 minutes				<input checked="" type="checkbox"/> Yes No				Yes <input checked="" type="checkbox"/> No							
Wife's KAST concerning her husband's alcohol related behavior (See Appendix 1 on Page 546)															
1	2	3	4	5	6	7	8	9	10	11	12	13	14	Total	
<input checked="" type="checkbox"/> 3.7	<input checked="" type="checkbox"/> 3.2	<input checked="" type="checkbox"/> 2.3	<input checked="" type="checkbox"/> 2.2	2.1	<input checked="" type="checkbox"/> 1.7	<input checked="" type="checkbox"/> 1.5	<input checked="" type="checkbox"/> 1.2	<input checked="" type="checkbox"/> 0.8	<input checked="" type="checkbox"/> 0.7	<input checked="" type="checkbox"/> 0.7	0.6	0.5	<input checked="" type="checkbox"/> 0.5	18.5	
-1.1	-1.1	-0.8	-0.7	-0.7	-0.4	-0.5	-0.2	-0.2	0	-0.1	-0.1	<input checked="" type="checkbox"/> 0	0		
?	?	?	?	<input checked="" type="checkbox"/> ?	?	?	?	?	?	?	?	?	?		
Analysis (See Analysis on Page 489)															
<input checked="" type="checkbox"/> A1	<input checked="" type="checkbox"/> A2	A3	A4	<input checked="" type="checkbox"/> A5	<input checked="" type="checkbox"/> A6	<input checked="" type="checkbox"/> A7	<input checked="" type="checkbox"/> B1	B2	<input checked="" type="checkbox"/> B3	<input checked="" type="checkbox"/> B4	<input checked="" type="checkbox"/> B5	<input checked="" type="checkbox"/> B6	G1		
<input checked="" type="checkbox"/> C1	<input checked="" type="checkbox"/> C2	C3	C4	<input checked="" type="checkbox"/> C5	<input checked="" type="checkbox"/> C6	<input checked="" type="checkbox"/> C7	D1	D2	D3	<input checked="" type="checkbox"/> D4	<input checked="" type="checkbox"/> D5	<input checked="" type="checkbox"/> D6	D7	<input checked="" type="checkbox"/> D8	
E1	<input checked="" type="checkbox"/> E2	<input checked="" type="checkbox"/> E3	<input checked="" type="checkbox"/> E4				<input checked="" type="checkbox"/> F1			<input checked="" type="checkbox"/> H1	<input checked="" type="checkbox"/> H2	<input checked="" type="checkbox"/> H3	<input checked="" type="checkbox"/> H4	<input checked="" type="checkbox"/> H5	<input checked="" type="checkbox"/> H6
Types of Problems (See Analysis on Page 489)															
<input checked="" type="checkbox"/> Verbal Abuse			<input checked="" type="checkbox"/> Physical Abuse			<input checked="" type="checkbox"/> Financial		<input checked="" type="checkbox"/> Psychological			<input checked="" type="checkbox"/> Shirinugui		<input checked="" type="checkbox"/> Child-Related		
Note															
Marital Status: Divorced															

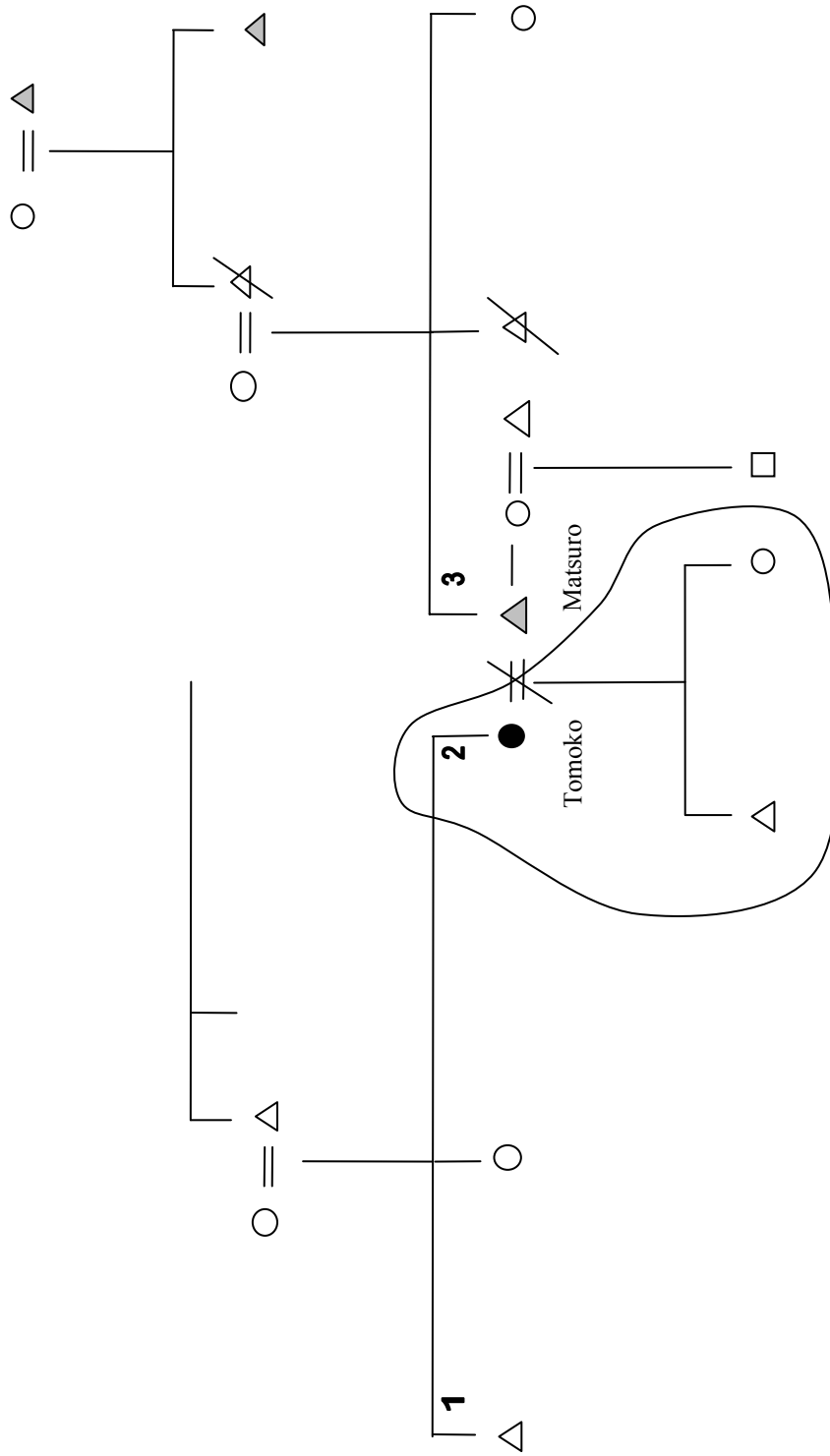

Tomoko Nitta

Tomoko is calm and also a good looking woman. When I asked her to describe herself in 2-3 lines, she answered, “Some people say that I am ‘serious.’ I think I am a ‘patient’ person.” She was divorced a year ago. This interview is based on Tomoko's memories of her married life.

Boyfriend-girlfriend relationship

Tomoko and Matsuro were working for the same company located in Tokyo. At a factory which produces electric appliances, Tomoko worked as an inspector of the factory’s products, and Matsuro as an operator of the factory’s machines. After going through group relations, a boyfriend-girlfriend relationship and then living together, they finally decided to marry one another when she was 20 years old.

----- How did your ex-husband drink before marriage? And, how did you think about it?

“First, since we had not drunk together, I wasn’t really aware of how he changed when drinking alcohol. There are photographs of that period in which he looks drunk with his friends. So, I am sure he was drinking at that time. In those days, however, I think I regarded him rather as the person who takes care of the drunk than the drunk who was taken care of by others. [Tomoko paused.] Already from that period, I was however aware that he is a person who becomes talkative when he drinks. As I said, our relationship developed from group of friends. Before becoming a couple, we were having a good time because we were in a group. But, when our relationship became special, we had the

problem of our conversation not lasting very long when we were only the two of us alone. Matsuro is a taciturn person. He is also a person who doesn't reveal his heart....doesn't express things in *honno* [real intension, see glossary on page 555]. Sometimes I am afraid of him since I don't know what he is thinking, at all. Anyway, that aside, when he drinks, he talks. And, because he becomes talkative, there was a time when I used to think that Matsuro's drinking is something good, something that makes us happy.”

Living together before marriage

At the age of 20, Tomoko became engaged to Matsuro and they started living together.

----- You married quite early.

“Yes. My mother also got married at this age. Since I wanted to be like my parents, I decided to follow their pattern. [Tomoko paused.] But from the first day when we start living together, things were different from what I had expected. I felt I was treated rudely. I thought ‘I may not be treated properly by him.’”

-----Are you talking about your ex-husband's rudeness in terms of domestic tasks or things related to night life, something related to sex?

“It is about sex.”

-----Is it about "*iya mo iya mo suki no uchi*" [woman's no, no during sex really means yes, yes, a vulgar phrase in Japan]?

“Yes.” [This topic will be described later].

----- How about your life as a housekeeper? Was he rude to you in this sense?

“No. From the beginning, since I thought I am the one who must be responsible for house chores, I didn’t think I was ill-treated. Of course, there was a time when I dreamed we could do the domestic tasks together. But, that is something that I didn’t really expect from him, right from the beginning.”

After living together for three months [not yet married], Tomoko became pregnant; she aborted the child.

“I determined to have the abortion. I started to feel uncomfortable about our future marriage. I also knew I couldn’t raise a child at that time. I thought that having a child is not yet necessary for our relationship.”

----- What was the reaction of your ex-husband when you became pregnant and you decided to abort the baby?

“Neither happy nor upset.”

She continued.

“But what really comes to my mind is he asked for sex the evening of the day I had the operation. I said “Stop” to him, and he withdrew. But, I still cannot forgive him for what he did on that day. [With moment of pause] Around this time, I really considered calling off our engagement.”

----- But you married him, right? In spite of feeling the uneasiness about your future married life, why did you still decide to get married with your ex-husband?

“My relationship with him was my first love relationship. At that time, I somehow believed in marrying the man of my first love. And because of this, I thought I must not break up our relationship. In addition, I already had the abortion experience, which made me think that I was already *kizumono* [a damaged commodity] at that time. I also felt that it would be financially difficult for me to live without him if we got separated. There was also a feeling in my mind that if we break up, no other man will ever accept me later. I also felt at that time that it was the meaning of my life to sacrifice myself for him.”

-----This is strange to hear from such a beautiful woman like you, saying that no one else will accept you if you break up with this man. I am not trying to flatter you.

“My self-esteem is very low.”

Our talk returned to the subject of why Tomoko decided to get married anyhow.

“I was also stubborn against my parents. Since my father persisted that I shouldn’t marry at such an early age, I wanted to convince them. I wanted them to know that I can marry well, so I had to marry well.”

[Ex-] husband's drinking

Matsuro drinking problems became severe after just one week had passed since their marriage. Tomoko says she already started being discontent about his drinking from around this time.

“For the first week after the marriage, he returned home like an ordinary man. But after that, he went out drinking with his drinking colleagues and came back home after midnight every day. One day, because of this, I asked him, ‘Why do you have to drink so much every day?’ Then, he answered that it was because of his coworkers who advised him: ‘The beginning is the important part of married life. Make sure you teach her especially at the beginning. Make sure you *chokyosuru* [≈train, a word used to train animals such as horses and dogs or beasts] her right from the start.’”

----- You are saying that your ex-husband was intentionally drinking every day in order to make you accustomed to a troublesome husband, correct?

“Yes. I also felt upset when I heard about this. In those days, I also used to think that ‘the beginning is important for everything [a common Japanese phrase].’ But, the way I applied the phrase in our life was different from how he did it. I was an innocent child who did not know my way around in society. I had a dream in my married life: a purpose of carrying out mutual growth through our married life.”

Husband's drinking problems worsen and rape within the household

It was during the time when Tomoko’s oldest son was about two years old, that her husband’s drinking problems were already worsening which negatively influenced his performance at work. This was also the time when she had her second child.

“His drinking problems became severe. Sometimes he drank and quarreled with other people. He also started causing trouble at work.”

----- Was there any physical violence at the time?

“For me, sex was violence. I disliked sex, therefore I tried to escape from it. One day, I was raped on the stairs. He dragged me down by my ankle when I tried to climb up the stairs to escape. There were also various kinds of violence. There was a time when he raped me in front of my baby.”

-----That’s awful. [Pause. I was lost for words.] Was he drunk during these occasions?

“Yes. At such times, he was almost always drunk. I did not like his forceful sex. Often I even thought, ‘if he wants such sex so much, can’t he go to the professionals and perform at such places?!’ In fact, it seems like he was actually going to such places [red light district]. [Tomoko paused.] Well...if he goes to such places and satisfies himself, I was [somewhat] fine. But that wasn’t it for him. He told me of all the various experiences he had at those places. I did not want to hear such things. But he didn’t stop telling me his stories.” She was calm. “So I said to him, ‘Why do you tell me all this? I don't want to hear about your sexual experiences with other people.’ Then he replied that he was doing this for me. According to him, the reason why I dislike sex was because of his lack of skill in sex. Therefore in order to overcome the situation, he must study and thus be ‘diligent.’”

Contrary to the upsurge of angry emotion observed on my side, Tomoko was absolutely calm. The tone of her voice never changed: it was a plain cool tone without any variation.

“At that time, there was a news story on T.V. about a trial concerning domestic rape in the U.S. As a person who believed in mutual agreement regarding sex, I was very touched by that news. So, to let Matsuro understand about my feeling, I encouraged him to watch the news and asked for his thoughts on this issue. But, unfortunately, he didn’t show any positive reaction.”

Non-physical [verbal] violence

Besides sexual assault against his wife, Tomoko's husband did not seem to be very physically abusive. However, Tomoko seems to have suffered a lot from non-physical [verbal] violence by her ex-husband.

“He criticized and made fun of me for everything, such as domestic chores, bringing up the children, my appearance, my performance at sex. For instance, he complained that the meals that I made were too repetitive with not enough variation. When I tried to get my driver's license [acquiring driver's license is often not easy in Japan.], he put me down by saying ‘you *still* can't get the driver's license?’ etc.”

----- Was there any abuse to the child?

“Yes. He frequently bullied his oldest son. Although he is a boy, he used to carry stuffed animals. So he said, ‘You are man, but behave like a woman!’ with an attitude. Sometimes he said to his son, ‘Mommy is mine, so stay away from her!’”

-----That sounds like an opposite version of the Oedipus' story.

“Yes. It seems like my [ex-] husband carried a feeling similar to jealousy against his son.”

-----Did he often get jealous and try to control your behavior, such as by listening to your conversations on the phone and checking to whom you are talking all the time?

“Yes. Every time I went out, he checked where I was going. He really hated me doing make-up. There was a time when he shouted, ‘I will throw away your dressing table!’ while I was doing my make-up. Sometimes he suspected me having an affair with my superior at work. Of course I didn’t do anything like that. It was him who was actually having an affair.”

Tomoko's child abuse

Tomoko confesses that once she pointed a kitchen knife at her children.

“I was mentally ill. On top of my husband’s drinking problems and husband’s sex problems, the children were still small, and I wanted to be a ‘good wife.’ It was this kind of daily trouble that led me to this madness. One day, my two children were crying loud to get attention from me. Somehow, I couldn’t bear the situation any more. The next thing I noticed was that I was pointing a kitchen knife at one of my children. ‘What a fearful thing I have done!’ I thought. Crying out ‘It’s mommy [not you children] who really wants to cry!’ I remember all three of us crying loudly while lying on the floor that afternoon in the kitchen. This happened when I was 25 years old.”

Somebody for advice

-----Was there anyone to whom you could talk about such feelings?

“Nobody.”

----Any friend?

“Since I was living in Tokyo [distant from her hometown], there was no one whom I could call a ‘close friend’ [a friend to whom she could frankly talk about her personal problems] at that time.

----- Any relative?

“I once wrote a letter to my mother-in-law concerning his drinking problems.”

-----Can you tell me more about that letter?

“I wrote about his general drinking behavior and how he abuses his children, etc.”

-----Did you write about his sexual problem(s) in the letter?

“No. In that letter, I mainly wrote about his drinking problems. But, she [Tomoko's mother-in-law] didn't seem to understand my problem. The reply letter basically said, ‘You married since you loved him. Tolerate such things.’ When I read the letter, I thought ‘I can't be helped. It seems like she is on her son's side.’”

Consulting obstetrician, again

Although she did not have people to talk about her problems, she thought about consulting an obstetrician.

“Around that period, I became pregnant again [4th time] and so was seeing an obstetrician. I trusted my obstetrician, therefore I thought that he might be able to understand my situation.”

In fact, there was a lot more than just the domestic problems, about which she wanted to talk to this obstetrician.

“Around that period, because my physical condition wasn’t good in various respects, I was going to various medical institutions. One day, I went to an internal medicine practice. Though the place I went to was just an internal medicine practice, I had a medical examination which you have at the obstetrician.”

-----What do you mean by "examination you have at obstetrician"?

“That is removing your bottom clothes, lying down on the bed and so on...”

----- Was that related to your claimed problem?

“No. It was not related to my problem at all. It was very clear to me that the internal medicine doctor was doing something that he is not supposed to do. His hand was trembling and he was unusually angry. So, including this, I wanted the obstetrician to hear my stories.”

-----But, you're saying that you wanted to means that you actually did not talk to him about it after all, right?

“Yes, you are right. But, to my husband I talked about this incident; he didn't react at all, though.”

The second abortion

For the forth pregnancy, Tomoko decided to abort again.

-----Didn't your [ex-] husband use contraceptive?

“He doesn't like those things. [Tomoko paused] So, I was thinking to use the intrauterine device. But a specialist advised me that using it is too early for me since I had just given birth to my second child. I don't know why. Anyway, it was around this time when I became pregnant again.”

In the following, Tomoko describes her psychological process of making the decision to abort the baby.

“[The reason why I came to this conclusion is that] at this time, he was always drinking and getting drunk. In addition, I already had two children. I was also not confident to have another new baby and raise it. Of course, taking care of my husband was a lot more troublesome than just taking care of the children. [Tomoko paused.] When I consulted my husband about my pregnancy, it seems like he did not care whether I give birth or not. He said something like, ‘Since two or three don’t make any difference to me, whatever you do is fine.’ [Tomoko paused.] Anyway, because of this, I went through the problem all by myself and also determined the abortion all by myself as well.”

Ex-husband's drinking habit

----- How does he drink in general?

“His drinking pattern fluctuated. He was not a person who drinks every day. There were times when he drinks everyday, but there were also times where he did not drink at all. Actually, I don’t exactly know how often and how much he drank since he often drank outside. There were sometimes occasions, such as Christmas and birthdays, where he drank at home. All the pictures from these occasions have beer and *sake* bottles in them [Tomoko, smiled wryly]. Always when he drank, he became dead drunk...”

-----Do you have any idea how much he was drinking in total?

“When he wanted to, I think he was able to drink 1 *sho* [≈ 0.477 gallon] of *sake*.”

Husband's financial violence and Tomoko's part-time work

From around this time, Tomoko's husband stopped giving her the household money. From his 450,000 yen [US\$ 4,091] salary, he took his allowance which was about 2-300,000 yen [US\$ 1,818 - 2,727], and gave the rest to his wife.²⁰ During the time when his drinking problem was most severe, he did not contribute any money to the household. The lack of household funds led Tomoko to secure the family's living expenses by herself.

“I couldn't depend only on him. So, I started working part-time at a flower shop.”

The call from the husband's boss

The ex-husband's drinking problems worsened as time passed. When Tomoko was in her mid-thirties, he was frequently causing trouble at work.

“He caused accidents. For example, while he was driving a machine carrying the company's goods, he banged into a nearby building and broke the building. There was a time when he burned himself, too. I heard that he sometimes just disappeared during work hours.”

-----Do you think he was hiding and drinking during that time?

²⁰ In Japan, it is common for many husbands give all their salary to their wives. In that case, the wife's role is to manage the living expenses for the family.

“Yes. He was probably drinking. He started involving people in his problem, not only our family but also the people at work. Then, one day, I was called by his company’s boss. The superior recommended me to take Matsuro to the psychiatry ward for an examination. At that time, I was buried in problems and didn’t know what to do. So, when his boss advised me to do this, I agreed with him from the bottom of my heart.”

As advised, Matsuro consulted the psychiatry ward of a big hospital. Here, the doctor diagnosed his depression and mania problem. Later on, Matsuro consulted a doctor at the hospital who specializes in alcohol treatment.

We can still be saved. We can start all over again

-----When his problem was linked to alcohol dependence, what was your feeling?

“Now, when I recall those days, I feel that my life has gone through the bottom several times before then. I therefore should have divorced him a lot earlier. But, I in those days I wasn’t yet 100% convinced that we can’t live together anymore. So, when he was diagnosed with alcohol dependence syndrome and went into the alcoholic ward, I thought, ‘we can still be saved.’ By learning more about his problem, by participating the family’s meeting, I still had hope of rescuing our relationship.”

At the self-help group

-----When your husband started the medical treatment and you started the self-help group, I assume you felt many things. Were there any statements or advice from other people at that time that touched you and changed the direction of your life?

“I remember a doctor who said to me, ‘You can live in any way you want.’”

-----Tell me about your thoughts at the self-help group in which you participated?

“Until then, I did not have anyone with whom I could talk about my problem. So, I thought, ‘there is a place where I can speak about my problem from my heart,’ ‘There is a place where I can speak about myself in comfort,’ and ‘I am allowed to talk about these things.’”

Understanding herself

-----Through your participation in self-help groups, how did you come to understand yourself?

“I think I have a co-dependence problem.”

Tomoko believes that her low self-esteem and inability to talk in *honne* [talk openly, see glossary on page 555] come from the ill-treatment by her aunts and uncles during her childhood.

“I think my low confidence comes from the ill-treatment during my young days when I was often put down by my aunts and uncles. They hurt me, but I always endured the situation.”

-----Who treated you badly, and what did they do to you?

“[I was ill-treated by] my father’s siblings. The worst one was my aunt. She often visited our house. Whenever she came, she spoke ill of my mother and my siblings. In addition, she criticized my attitude and behavior such as the way I greet people and so on. Because of this environment, I was always feeling inferior, thinking ‘I am a useless person.’”

-----You are saying that this environment is the factor which influenced the development of your character? [Tomoko nodded.] What kind of woman was this aunt? Was she a happy woman from your perspective?

“No, I don’t think she was a happy person, at all. I think she was venting her frustration by saying mean things about us.”

Tomoko described the reasons of her co-dependence problem further.

“In addition, I have long believed that the relationship between my parents was good, but I learned that it wasn’t as good as I had believed. Recently I noticed that my mother is just bearing the situation. I noticed this after my marriage.”

-----You think this [mother enduring the situation and creating harmonious atmosphere in the house without making the children notice about her bad feelings] is also related to your co-dependence problem?

“Yes.”

Drinking again

Although he finally entered treatment for alcohol dependence syndrome, her ex-husband’s denial of his drinking problems was so strong that he refused to continue the treatment. Insisting that he was not an alcoholic, after 40 days of hospitalization, he decided to leave the hospital. After the hospitalization, he returned to his work; but he was completely spiritless during that time. After all, within several months after he left the hospital, he started drinking again.

Although Matsuro broke his abstinence, Tomoko kept going to the self-help group. She did this because, as she says, “no matter what happens to my husband, at least, I wanted to be saved.”

Separation

The situation of the family was *kateinai-rikon* [divorce within the household, see glossary in page 556].

“There was no conversation between us. At the end [the period before living separately], I didn’t cook for him nor do the laundry for him.”

Finally, she decided to live separately from him. The separation continued for 3 years until she formally divorced him.

-----Tell me about the actual cause of this separation.

“At that time, he gave me very little house money. There were times when he didn’t give me any money at all. Usually, I was managing the household with our savings and my own part-time salary. This economical situation made me think that it was meaningless to live together with him. I think it was this feeling that ultimately led to our separation. In addition, I had the feeling at that time that ‘if we don’t get separated, I might kill him or kill myself or I will go crazy.’ I didn’t care much about the shame in the society. Nor did I mind much about his drunken behaviors when he drinking. This however was simply because there was neither sex nor conversation, and he mostly drank outside.”

One day, Tomoko moved out of the house with her daughter.

----- Didn’t you take your son, too?

“My son didn’t come with us. Although he disliked his father, he didn’t want to get involved with our problem any further: he kept his indifferent attitude by remaining in the house.”

-----During the separation period, did your ex-husband stalk you, trying to find your new apartment and harass you in some way?

“No, that did not happen.”

--- Did he know where you were living at that time?

“Yes, he did.”

Daughter’s *hikikomori* [shut oneself in, see glossary on page 555]

The daughter has been refusing to go to school since she was 14 years old. Currently, she is in *hikikomori*. She has seen counselors several times.

----- What is the character of your daughter? Is she the typical “delinquent type [anger shows to the outside]” or is she “the quiet type [anger hidden inside]”?

“My daughter is rather an ‘honors student’ type [=serious, but she is now over 20 years old]. She was originally a very talkative girl. She went to counseling several times, but her denial is so strong that the counseling is not improving the situation. She also talked with a doctor who specializes in alcohol related treatment.”

----- Has she ever tried to kill herself, or anything in this direction?

“She has once taken large quantities of prescription medicine. I think she meant to commit suicide.”

-----What was the actual cause of this?

“Rather than a specific cause, I think this was due to the accumulated suffering in her life.”

Knife

-----Was there absolutely no physical violence besides the domestic rape you have already talked about? Are you sure even during the time when his drinking problems became severe?

“I believe there weren't any [physical violence].”

-----Absolutely no striking?

“There were times when he struck me several times.”

-----In fist, or in an open hand?

“Open hand.”

At this moment, something came to Tomoko's mind. She added.

“There was an occasion when the quarrel between me and Matsuro was so severe that my son had to intervene in our dispute. There were also occasions when my son and my husband quarreled so badly that I had to step into the fight, as well.”

-----Not a single experience of him using dangerous objects – a kitchen knife, army knife, bat – which can hurt you badly?

“No. There was nothing like that, I believe. But, [pause]...Matsuro used to have a 30 cm long knife. I don't know why he carried it. He used to have it since we got married. That knife was one day in my wardrobe drawer. My bedroom at that time was apart from his. I can't imagine myself moving his knife to where it was; it must have been him who put the knife in my drawer.”

----- I wonder why he put it there, too. What did you feel when you saw the knife? Did you feel any message from him by seeing the object?

“‘Please kill me.’ I also thought, ‘I will not be killed by such a thing.’”

----- “Please kill me” and not “I will kill you”?

“Yes. I think there was an aspect of him desiring to be stabbed by me. I say this since there was one time around this period, when we quarreled for something, he handed the knife, lay on the floor defenselessly, and said to me, ‘kill me!’”

---- Strange that he wants to die but not by himself but by asking you to kill him. Sounds very much like an *amae* [psychological] mechanism to me...

“I also thought, why in the world do I have to kill him, and become a murderer?! If he wants to die, why not do it by himself! I especially think so now.”

Because of such experiences, her ex-husband of this period is symbolized as “knife”—an image she still carries, even now.

Divorce

After being separated for 3 years, that was 4 years ago, Tomoko formally divorced her husband through a trial. Matsuuro is currently living with another woman [the woman is married, but she is separated from her husband].

“The trial was for our divorce. Matsuuro didn’t come to the court for the trial, not even once. Through the trial, it was determined by the judge that he has to pay us some living expenses every month. Unfortunately, this decision is not legally enforceable in Japan. Therefore, although he paid about 100,000 yen [≈US\$ 909] every month for a year, it reduced gradually and now it is completely gone.”

Currently Tomoko is unemployed. About half a year ago, she quit the flower shop where she had been working for more than 15 years. The reason for resigning this job was, as she says: “I wasn’t attracted to this workplace any more. I wanted to do something different, something new.” These days, while receiving the unemployment compensation from the government, she is going to a class to learn how to use a P.C.. She is also looking for a job where she can discover her ‘self.’

When I asked her to describe her present state of mind, she answered positively, “I would like to find a job soon. I also wish to meet a good man [Tomoko, smiling].” When I asked about her feeling towards her daughter, she answered, “For this, I would like to watch and wait. There is nothing I can do at this moment.”

The real problem

-----We have long been talking about your relationship with Matsuro since you met him and divorced him. Now that I have an idea about your relationship, I would like to know what you think was the real problem in your relationship?

“His drinking was certainly a problem. But, we had more serious problems, preceding his alcohol problem. Our relationship was a relationship where both of us were not able to talk with each other in *honne* [in real intention, openly, see glossary on page 555]. This is something I noticed by going to the self-help groups. Our problem was the problem of *kankeisei* [relationship]. When I think about it now, I think what we expected from one

another was different; and because of our lack of communication, what we did for each another failed the partner's expectation(s).”

-----What did you expect from Matsuro?

“I wanted him to be gentle....not dreadful. I also wanted him to lead me. He wasn’t really a person who leads a woman as a man.”

-----Could you give me an example for what you mean by “him leading you”?

“For example, if we have a date, or travel, I wanted him to take the initiative of where to go and/or what to do. I wanted him to decide all these things and lead me.”

Ex-husband

On top of being a taciturn person, Tomoko’s ex-husband was also *amaenbou* [“a baby with frequent *amae* behaviors” which means “a very dependant person.”] Tomoko said, for such an [ex-] husband she played the role of not only a “wife,” but also “a mother,” “an older sister,” and “the unpaid housekeeper.”

-----What do you think is the cause of this character? The character which also made him so fond of drinking? Tell me how you reason why your ex-husband came to be what he is right now?

“I think he lacks love from his parents. His older brother was born handicapped. Because of this, his parents’ attention was often concentrated on his brother and not on him. Being the youngest child might also be the reason of him being so skillful at conveying his *amae* [feeling of seeking care passively. See glossary on page 554]. He is so dependant, being so used to been taken care of. He is kind, though.... In addition, he is only a junior high-school graduate. This educational deficiency may be the factor contributing to his unconfident character.”

-----Why didn’t he go to high-school? Did he have problems, such as the family’s financial situation?

“It is certainly not because he was poor and couldn’t go even though he wanted to. Since he never talks about this, I don’t know why he didn’t go to high school.”

Besides this, Tomoko told me that his mother has a repressive character and also has a tendency to care too much about the impression of the public. Tomoko thinks that this is one of the reasons for some of the tension [family stress] existing in her [ex-] husband’s family.

Tomoko spoke about her tragic experience in the same tone throughout the interview. During this time, I was certainly more emotional than Tomoko who was talking about herself. How could she be so detached from such experiences? When I said to her, “you seldom show your emotions on your face,” she replied, “A doctor told me something like

that, too.” I wonder if this is something commonly observed among victimized women who have gone through severe experiences.

**Case 7. The problem of *kankeisei* [relationship]; inferiority stemmed from the feeling
'I am being fed.'**

Name				Age		Occupation									
Masako Murakami				54		Helper at a hospital									
Family						Ex-husband's Occupation									
<input checked="" type="checkbox"/> Nuclear		Extended		# of members		4 (divorced)		Computer support & maintenance							
Family members															
Taro	Husband			57		Workaholic, gambling addict, alcoholism									
Masako	Wife			54											
Kazue	First daughter			29											
Tsugie	Second daughter			28											
Total Interview Time				Wife Attending Self-help Group?				Ex-Husband Attending Self-help Group?							
First: 3 hour 20 minutes Second: 30 minutes				<input checked="" type="checkbox"/> Yes No				Yes <input type="checkbox"/> No							
Wife's KAST concerning her husband's alcohol related behavior (See Appendix 1 on Page 546)															
1	2	3	4	5	6	7	8	9	10	11	12	13	14	Total	
3.7	3.2	2.3	2.2	2.1	1.7	1.5	1.2	0.8	0.7	0.7	0.6	0.5	0.5		
-1.1	-1.1	-0.8	-0.7	-0.7	-0.4	-0.5	-0.2	-0.2	0	-0.1	-0.1	0	0		
?	?	?	?	?	?	?	?	?	?	?	?	?	?		
Analysis (See Analysis on Page 489)															
<input checked="" type="checkbox"/> A1	A2	A3	A4	<input checked="" type="checkbox"/> A5	<input checked="" type="checkbox"/> A6	<input checked="" type="checkbox"/> A7	<input checked="" type="checkbox"/> B1	B2	<input checked="" type="checkbox"/> B3	<input checked="" type="checkbox"/> B4	<input checked="" type="checkbox"/> B5	<input checked="" type="checkbox"/> B6	<input checked="" type="checkbox"/> G1		
<input checked="" type="checkbox"/> C1	C2	C3	C4	<input checked="" type="checkbox"/> C5	<input checked="" type="checkbox"/> C6	<input checked="" type="checkbox"/> C7	D1	D2	<input checked="" type="checkbox"/> D3	D4	D5	D6	D7	D8	
E1	E2	<input checked="" type="checkbox"/> E3	<input checked="" type="checkbox"/> E4				<input checked="" type="checkbox"/> F1			<input checked="" type="checkbox"/> H1	<input checked="" type="checkbox"/> H2	<input checked="" type="checkbox"/> H3	<input checked="" type="checkbox"/> H4	<input checked="" type="checkbox"/> H5	<input checked="" type="checkbox"/> H6
Types of Problems (See Analysis on Page 489)															
<input checked="" type="checkbox"/> Verbal Abuse		<input checked="" type="checkbox"/> Physical Abuse		<input checked="" type="checkbox"/> Financial		<input checked="" type="checkbox"/> Psychological		<input checked="" type="checkbox"/> Shirinugui		<input checked="" type="checkbox"/> Child-Related					
Note															
Marital Status: Divorced															

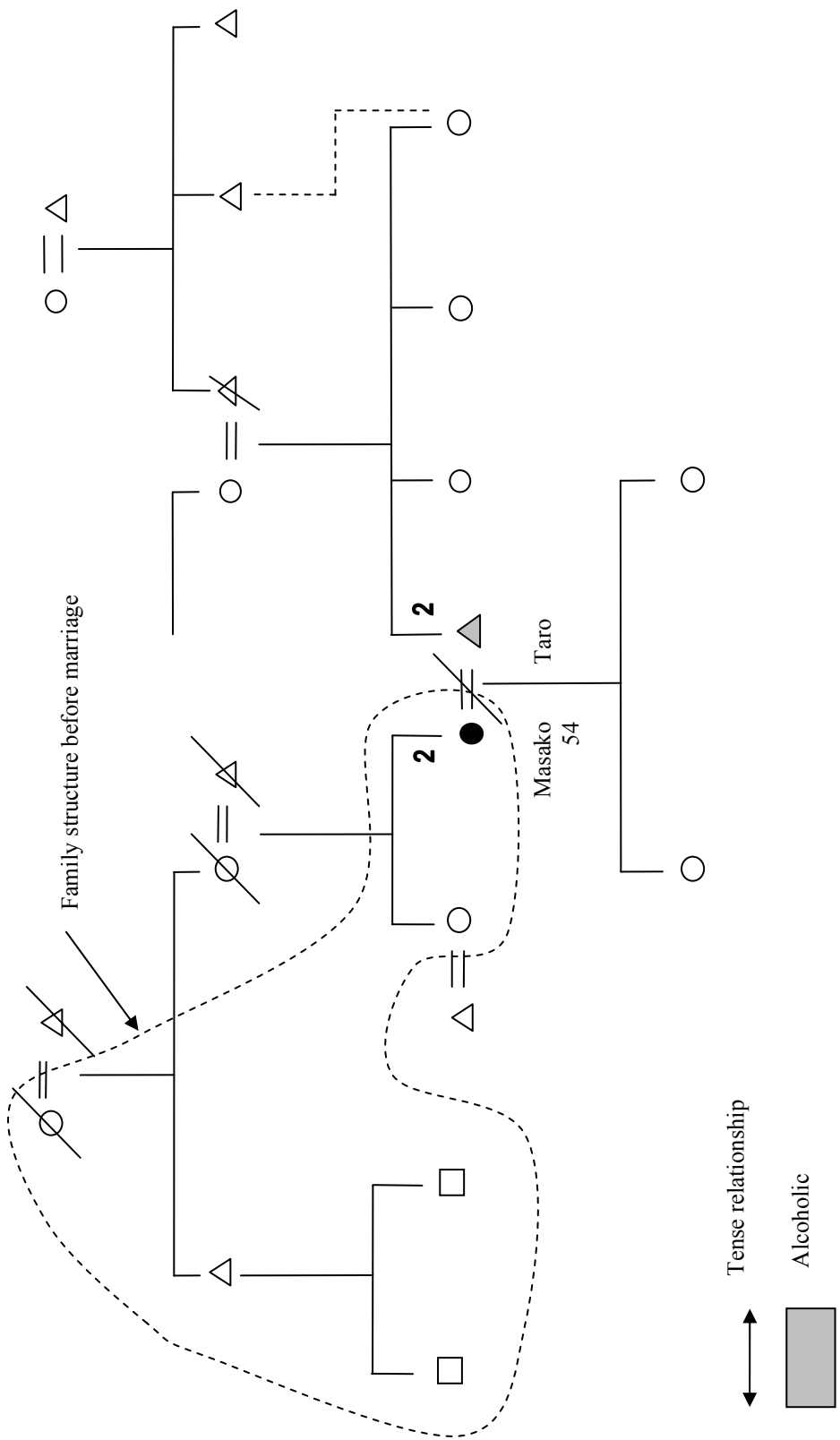

Masako Murakami

Masako looked like a current days Japanese young women: short lightly curled brown hair, slightly over her ears, with some of their tips intentionally flipped in various ways. Since her clothes are all in warm colors, the impression of warmth emanates from her appearance. At first glance, she appears “sweet and charming.” This impression, however, was replaced by “cheerful and full of vitality” right after she started speaking. She is a woman full of ardor.

Our encounter was somewhat different than the other interviews. Masako is an active member of an addiction problem related organization²¹. She manages events and study groups for the organization. One evening, I received a call from her. She introduced herself and said she heard from her friend that I was conducting interviews with alcoholics’ wives. She found this interesting and therefore asked me if I could give a public lecture at the study group she was organizing. When I accepted, the next day with very short notice, she came to the place where I was generally conducting the interviews and volunteered for an interview saying, “I just wanted to meet you before I see you at the lecture.” She is a very active person.

“I hate the word *kyoizon* [co-dependence]”

Masako appeared to me as a person who had overcome a big personal problem and had gone through some changes of character in the last several years, just like the “women who love too much” (Norwood 1985) or the women of “co-dependence” (Schaefer 1986, 1987) [see glossary on page 554] change after they realize their problem. When I was vaguely

²¹ The organization’s name is not disclosed to protect the privacy of the interviewee.

seeing her in such a way, she sensed my feeling immediately. I was surprised. She was awfully good at detecting people's thoughts.

“I hate the word *'kyoizon* [co-dependence].’ I therefore never use it... I also don't like the word *'kaifuku* [recovery].’ This is because I don't like the idea that in the past I was ‘wrong’ or was something ‘bad’... *'I in the past'* and *'I right now'* are both the same *'I.'* I am a person who wants to shine brightly all the time, and that is the way I want to be throughout my life...”

The various terminologies [e.g. “co-dependence” and “recovery”] expressed in her words made me think that she was quite knowledgeable about addiction related problems.

The root?

According to Masako, her ex-husband was a workaholic and had gambling and domestic violence problems in addition to his alcoholism problem.

“Workaholism, gambling addict, drug addict, alcoholism... the root is all the same.”

She said this with a definite tone, which immediately caught my attention. She seems to perceive addictive behaviors—e.g. drinking alcohol, using drugs, or gambling—as external/superficial behaviors which stem from a common root—the fundamental problem, with which I agree [The idea of some commonalities observed among various addicted

people has been my interest for a long time.] On what basis is she saying this? How is she picturing the root she just mentioned?

----- The Root?

“Yes. [Masako nodded]”

Since she did not elaborate any further on this, I could not gain any concise answer to this fundamental question. I think what Masako believes to be the common root, however, is well described in this interview. It is the problem of *kankeisei* [relationship], an unbalanced human relationship where non-addicted family members suppress or sacrifice themselves for the addicted one and start becoming numb to their own feelings.

The interview procedure

By the time I started asking the interview questions, we had talked quite a bit already. Masako had many things to say. She talks like a machine gun. Most interesting to me was her perception, where she marginalized her husband’s drinking problem in their relationship. Her husband, Taro, certainly had an alcoholism problem, but, it seemed to me that Masako treated Taro’s alcoholism as a symptom of the bigger problem which is the problem of *kankeisei* [relationship]. Whenever I tried to ask about alcohol related problems, which I did in most other case studies [e.g. How much did he drink? Was he violent when drunk?], she treated the question as unimportant and instead talked about what she

perceived as important. Because of this pattern, I decided to structure the interview according to the stages in her life.

----- Let's divide the interview into four big questions based on time: (1) before the wedding; (2) after the wedding until you noticed that he had a problem; (3) after you noticed that he had a problem; and (4) now. Tell me what happened during each period. After these, I will go back to each period again. At that time, I will ask you what you think about your past behaviors that you related from your current perspective. I will also ask what kind of advice you would give to people who are in a similar situation as you were.

Masako consented. As the interview progressed, Masako was calling the four time periods by these terms: (1) period before wedding; (2) "*tsukushi-jidai*" [sacrificing period]; (3) "*donzoko-jidai*" [the very bottom of life period]; and (4) now. My discussion will therefore use these terms.

(1) Period before marriage

Masako's personality

As described before, Masako is a very cheerful person and full of vitality. She says this spirited man-like character that likes taking the initiative in various activities was already present when she was a child.

"During my school days, I belonged to a strong tennis club which won competitions often. I was a captain in that club. Our women's team was especially strong, so we often practiced

with men of the men's team. Because of this, the relations of women and men among the school's tennis club were strong. But since I felt uncomfortable with the atmosphere created by women and men being friendly like that, I was always with the girls group, talking only with girls. I was not used to communicating properly with men at that time.”

-----You were *kouha* [strait-laced person/serious person].

“[Masako reacted surprised.] You call this behavior ‘*kouha*’? Hmm. I have never thought in this way. Hmm. I may indeed be ‘*kouha*.’”

Masako nodded and murmured ‘I may indeed be *kouha*’ several times after this during the interview.

How Masako met Taro

After graduating from high-school, she worked for a company which manufactures electrical appliances. She was a secretary at that place. Taro, her husband, was maintaining the company's computers.

“He was a very hard worker. He worked several days staying up all night. Seeing such a man, I *happened* [Her words implied regret.] to think, ‘Wow, he is amazing!’”

He was not a university graduate but was an extremely hard working man. Being acquainted since she was 23 years old, Masako married Taro at the age of 25.

“I wasn’t *deeply* in love with him, though. To tell the truth, I was crazy about his big-brother-like *senpai* [senior]. He was good looking and nice... I even wrote a letter to him about my feelings, but he had someone else in mind. He married a *Mama* [Female manager of adult entertainments, see glossary on page 556] of a bar. [Masako paused.] I wasn’t unattractive; there were men who asked me for dates. And among them, there were good men when I recall back now... Weird... I somehow don’t get attracted to men who seek me. I like to seek instead of being sought. I wonder why. [Masako paused.]”

Recalling her past, she said she played the “*tsukusu onna* [single-mindedly devoted woman to the level of sacrifice]” to her husband.

“I made him rice balls or fixed his clothes’ buttons. I wasn’t doing this only for him. I was doing it for other people, too. Anyway, thinking about it now, I already had the symptom of ‘*tsukusu onna*’ from that time. Of course, I did not consider this behavior as sacrificing at that time at all. I rather thought it a ‘natural thing to do’ or ‘something I must do according to the norm.’”

The background of Masako's devoted character

Masako thinks that her devoted character comes from her family environment where she grew up. Masako and her younger sister lost their parents when they were still young and were brought up by their uncle, their mother’s brother. This man was a very traditional minded masculine man.

“Uncle took care of us when he was still in his early thirties. He had three children at that time. This uncle was an ‘extremely manly man.’ He was working at a securities firm and was considered the ‘capable man.’ He strongly held an idea about how men should behave and so forth. How could I describe him...Yeah! He was like *Hoshi Huma*’s father [A character of a classic Japanese comic *Kyojin no Hoshi*. He is absurdly severe]. [Hearing the expression ‘*Hoshi Huma*’s father,’ I laughed.] Since I was brought up under such a *samurai*-like uncle, I considered ideas such as ‘a wife should walk three steps behind her husband’ or ‘a woman’s virtue is to back up her man’ as natural. Under the influence of such a family environment, I held the idea that marriage is something like a duty where ‘the woman raises children responsibly and supports her husband who must work outside.’”

A strong desire to get out from the house

Masako had a strong desire to get out of the house.

“I always wanted to get out from that house. Perhaps marriage was the means to escape from that life. More than liking Taro, I had a strong desire to get out of that house at that time.”

-----Why did you want to leave so much?

“I always felt that ‘there is no room for me’ or ‘I should not be here’ in that house. I think my sister felt like that as well. Nowadays, we talk about the feelings we held in the past and

sympathize with each other. Contrary to me who married a manly man, however, my sister married a quiet and kind man.”

According to Masako, her sister is currently happily married.

(2) *Tsukushi-jidai* [sacrificing period]

The ideal housewife

Masako played her housewife role perfectly.

“The room was always made beautiful. When someone mentioned, for example, that the shelf was dirty, I cleaned it immediately. I did all this since I wished to be a good wife for him. I always served and served, and sacrificed myself. When it comes to *osechi* dishes [special collection dishes prepared for the New Year’s Day. It usually comes in *osechi* box(es). Making three boxes of dishes is considered superb in Japan.], I made seven or eight boxes. I liked seeing Taro’s pleased face and because of this, I made lots of effort. I have a habit of making an effort, perhaps too much, in order to look good to others.”

-----Why are you so conscious about other people’s perception?

“I wonder why, too. Perhaps it is a cultural thing... [Masako tilted her head to the side and smiled.] I would never say such things these days, but in the past I used to write to friends things such as ‘Don’t forget your femininity’ and ‘Please keep your femininity alive.’ I was truly writing such things. [Masako laughed.]”

Episode of problem in the early days

-----Tell me about when your husband's problem first came to your attention.

“You are asking me when he pissed me off the first time, right? Well...I was usually managing the family budget, but whenever he became angry he said, ‘Give the passbook to me.’ He said this every time when he became angry. He held the idea that ‘He was feeding me’ while I felt inferior and dependent because ‘I was being fed.’ [Masako paused.] One day, my husband's colleague's family stayed at our house over night. I didn't like them, especially the wife. She was an impudent person who showed no sense of gratitude but rather took everything I did for granted. Anyway, they came to visit our house again. When I heard about it, I couldn't believe my husband allowed this to happen. So, I opposed it, but contrary to my expectation, my husband got angry at me. Perhaps he wasn't happy that I was pursuing a housewife life. He scolded me saying ‘Give that passbook to me!’”

-----That sounds abusive.

“Well, yes I think he was haughty when I think about it now. By the way, he was physically violent, too. He probably wanted to control me... Anyway, that aside, at that time, as I said, I held a sense of inferiority because I felt I was being fed by him. I had the feeling that ‘without him, I cannot do anything.’”

-----Housework is work, too. [It's just not paid.]

“Indeed. And I was like a model housewife. But still, I wasn’t able to get rid of the sentiment that ‘I was being fed.’ It was deeply ingrained in me.”

While speaking, Masako repeatedly said, ‘Gosh, I am getting angry!’ She was excited.

“My husband used to say things like: ‘When I’m not around, you could do whatever you want. But when I am around, *ore o tatero* [make sure I have the priority]. So here I was doing whatever I wanted: taking classes for sewing, knitting, patchwork, etc. I was also involved in clubs for badminton, volleyball, tennis, etc. My lifestyle was that, for example, I woke up in the morning, started knitting, intermediate time—prepare breakfast for him and send him off to work—then start knitting again....”

-----If you felt small since you were using his money, then why not earn money by yourself? Did you considered working outside?

“I never thought about working outside. [Before marriage] I worked outside for six years [as a secretary] and that was enough for me. The idea that ‘I want to work outside,’ therefore, never even occurred to me.”

(3) *Donzoko-jidai* [the bottom of life period]

Masako's pain due to the feeling 'I am being fed'

Whenever Taro was absent, Masako used her time freely. Whenever Taro was present, however, she did everything for him as his wife. She felt always obliged to do the housework when he was around since there was guilt in her, which stemmed from the feeling 'I am being fed.' As time passed by, this duty as a housewife started to become an intolerable burden for Masako and finally became an abnormal situation for the household. Masako calls this 'the problem of *kankeisei* [problem in relationship].

“It was around the time when my first daughter was in the first grade in elementary school. It was a day on which I had a tennis competition. On that day, however, my husband was ill and so he stayed at home resting. Around that time, his hardworking habit turned him into depression; he frequently stayed at home resting in bed. You see, he continuously worked without any sleep for two weeks, or something like that frequently. His absence on that day was also for this reason. I felt bad for participating in the competition because he was feeling ill and staying in the bed at that time. The next thing I noticed was that I was calling my friend saying 'Sorry, I can't go today.' [Masako made a gesture of calling somebody via phone.] At that moment, a big question came up in my mind: 'What am I doing? Why do I have to behave like this?'; 'Who am I? Am I a maid?'”

From around this time, Taro started missing work and going gambling [e.g. pachinko, slot machine, and horse racing]. He also started drinking at this time and became mad easily.

-----Is it relevant to say that your married life was the so-called '*kateinai rikon*' [divorce within the household] at that time?

“The situation of *kateinai rikon* was already there a long time earlier. Our bedrooms were separate. Sex, too. In terms of sex...It was far from the ideal ‘in-depth mutual understanding.’ He was forceful when I refused. I even thought, ‘Am I a toy?’ [Masako paused.] Anyhow, he was always a work-centered person. Since he was dead-tired when he returned from work, he didn’t do anything for the family, really nothing. For example, he didn’t go to the father’s visiting day or the sports day at our children’s school. Although he promised the children that he would go, he never went; he said ‘I am not going’ on that day and that was it. This was the case for the ancestor’s worship, too. Because he says ‘I am not going,’ I always went to the family tomb by myself and worshiped the ancestors alone. There was no space for arguing since if I said anything, the next thing he said was ‘Shut up!’ In those days, I didn’t have a driver’s license. Since there are many restrictions in life if you can’t drive, I went to a driving school trying to get a driver’s license when I was in my thirties. Afterwards, I was able to drive my children to their piano lessons and so on.”

-----From your current outspoken character, it is hard for me to imagine that you were unable to argue with your husband’.

“Believe it or not, I really was like that. As you say, I indeed say things that pop up my mind immediately. I am quite frank in general, even to my mother-in-law or to unfamiliar people. In fact, to my husband too, if there were other people accompanying us, I was able

to be frank to him. But, when we were only two of us....I couldn't say what I wanted to say. Because of this problem, my feeling towards him changed as time passed by: from 'perhaps it is better if he is not around' to 'I feel more natural when he is not around,' and then to 'I would rather not see him at all.'"

-----I wonder why you think in that way.

"Well, I think the feelings 'He is *allowing* me to do whatever I want to do,' 'I am being fed,' and 'He is working outside' were the basis of all my behavior in front of him."

Husband's hospitalization

Masako's husband's absence at work increased as time went by. Every time when he missed work, she called his workplace for him and said 'He will not be able to go to work today because he is ill.' As time passed by, his hospitalization occurred repeatedly, too. This was about three to four years before they got divorced.

"We were told that he was a workaholic. He was hospitalized for three months at a hospital [a hospital which specializes in addiction problems such as alcoholism, drug addiction, and workaholism.]. At the hospital, he was always an 'ideal patient.' This means that he didn't run out of the hospital like many other patients did. Anyway, after three months of hospitalization, he came back home."

Taro's hospitalization gave Masako an opportunity to consult a doctor about her problem.

“At that hospital, there was a doctor and I was able to talk about my hidden problem in my heart. I told him about the passbook problem. The doctor asked me, ‘Why do you hand the passbook to him?’ I answered, ‘Because it is his money.’ Then he said, ‘Well, you are doing housework all right. There is no need to give the passbook to him.’ When I heard this, I was very much relieved. So, the next time when the problem occurred and Taro tried to take the passbook away from me, I refused. But then, he flew into a rage and became extremely violent. This was the moment I thought, ‘I cannot be with him any more....’”

At that time, Taro was weak, no longer a constantly moving working machine as he used to be. The fights between him and Masako went on every day. Sometimes, their fight went to the extent where he used a golf-club.

“Around the end before we got divorced, the situation was ‘I will get killed. Otherwise, I might kill him’”

Mother-child capsule

During that time, Masako grumbled about Taro to her children frequently. She thinks this situation was creating the so-called ‘mother-child capsule.’

“I often grumbled about Taro’s intolerant behavior to my children especially to my oldest daughter. She was in about eighth or ninth grade in junior high school. I grumbled Taro is this and that, on and on.... So, probably she understood my feelings, she sometimes went

against him saying ‘Father, it’s your fault for doing this and this!’ When she opposed him, Taro used violence against her as well. During the fight, her hair was grabbed like this. [Masako grabbed her hair and looked as if she was pulled by her hair.]”

Even though her grumbling made the relationship between the oldest daughter and her father bad, Masako still did not stop grumbling to her children. In this environment, the oldest daughter, who could not bear the situation any longer, finally said to her mother: “Mom, I am your child. [I am neither your counselor nor your friend.] If you are not going to get out of this house, I am going to.”

-----Do you think your daughter has co-dependence problem [short for ‘adult children’, see glossary on page 554] problem from your perspective?

“[I don’t think so.] She encountered very good teachers at her junior high-school and high school. Through those relationships, she was able to regain her self.”

This oldest daughter went to graduate school and is now traveling to many countries all over the world. Like her mother, she has an active personality. According to Masako, she is quite a bookworm as well as an academically bent person, too.

Running away from the house

From these days, Masako met many people, including professionals, engaged in addiction related problems. She also met a doctor who is famous for treating patients with alcohol related problems in the region.

“The doctor told me that although Taro has a workaholic problem, I myself have a problem, too. He therefore recommended that I attend a self-help group. At the beginning, I was very discontent with this suggestion, thinking, ‘Why do *I* have to attend such a group?! It is him, Taro, who is bad!’ But thinking about it now, attending the self-help group was something good for me. There were conversations such as me being advised ‘Get divorced!’ by others, and I answer things like ‘But if I get divorced, I can’t eat [survive] since I don’t have any skills.’”

At this time, Masako started to plan to get out of the house. She called this period the *donzoko-jotai* [bottom of life situation, see glossary on page 555].

“I was thinking to secretly leave the house one day. Although I was pretending to be like usual, I was secretly preparing little by little everyday for my departure by packing my clothes and stuff in the car’s trunk. One day, the X day finally came. I was temporarily moving into my girl-friend’s place. Acting with discretion, me and my friend--she was helping me move--quietly got into the car and started the engine to leave the house.

[Masako pretended she was turning the car key and starting the engine.] But, gosh! Why did it have to happen just at that time! The car engine stalled!!! Taro heard the noise and

immediately came out of the house with a wooden sword in his hand. He thought he would be in trouble if I ran away. From the outside he shouted to me in the car, ‘Open the car!’ My girl-friend was controlling the car at that time. He also roared out to my friend to stop the engine and get out. I asked her to start the car and leave. I was shouting loudly, ‘Please ESCAPE!!!’ So, we left. When we arrived at her place a few hours later and put the children to bed, it was already midnight. [Masako paused.] It seems like Taro was very angry because I left him secretly without letting him know about it. Driving his motorbike, he was searching for us everywhere, from the children’s schools, my friends’ houses, and even my children’s friends’ houses. [Masako paused.] Some days after this incident, things had calmed down a little bit. One day, my daughter asked me to take her to her old friend’s house. After dropping her off there and driving through the house’s neighborhood, I saw my husband driving his motorbike on the other side of the road. It was really coincidence. He was right in front of me, at the other side of the road!”

-----So what happened, then?

“He noticed immediately. He made me get out of the car. He grabbed my hair and dragged me out. I was saying something like ‘Stop it!’ and/or ‘No!’ I was taken to the roadside. Taro pressured me to release where I had gone: ‘At least tell me where you are staying.’ I had no choice. I had to tell him.”

***Kireina wakare* [clean break-up]**

At that time, Masako had been asking Taro for a divorce. Taro, on the other hand, refused, saying “We will not get divorced.”

“I wanted to have a clean breakup. I was being told by the doctor that there are two ways of breaking up—clean break-ups and messy break-ups—and was recommended to do the clean break-up. I therefore wanted to sort things out properly and break up cleanly.”

The ideal separation, however, was not as easy as Masako imagined. Taro suggested they live temporarily separated for three years before an official divorce.

Taro who refuses to get divorced

During the separation, Taro came to Masako’s apartment by his motorbike, and tried to negotiate about their problems. He was often drunk at those occasions. He shouted ‘Open the door!’ and forcefully tried to break open the door.

“I didn’t open the door by any means even if he made noise and became troublesome to the neighbors. Actually, I did let him into the house once because I worried about the nuisance to the neighbors. At that time, I had a horrible experience; I was badly injured, severely hit and kicked. So I learned from that. No matter what forceful means he used, I didn’t open the door. I even told him that I will call the police. In fact, I informed the local police about my problem beforehand and asked them for help. Anyway, so, one day, he came to my apartment to cause trouble like usual and I actually called the police. When he heard the

sirens, Taro was gone. [Masako paused.] When that happened, Taro finally seemed to give up. The next day, he approached me and said, ‘Okay. Let’s get divorced.’ There is a saying ‘Never put off till tomorrow what may be done today.’ We went to the public office immediately and went through the procedure for the divorce. Since he agreed to transfer the ownership of the car to me, we went to the office together and performed that procedure as well.”

It seems that the clean break-up was realized in some sense. This was four months after Taro had suggested to temporarily live separated for three years.

(4) Now

Masako is currently working as a helper at a hospital and volunteers as a domestic violence telephone counselor, too. She is also looking for a better job.

Recalling the past

(1) Before marriage

-----What do you think about your role as a ‘*tsukusu onna*’ [single-mindedly devoted woman to the level of sacrifice] in the early period of your marriage? Is there any advice you could give to women in a situation like yours in the past?

“Make sure you express yourself from the beginning and honestly. There is no necessity to devote and sacrifice yourself so much. An important part of marriage is the relationship of mutual understanding. It is also the life that you build up together by helping each other. It

is definitely not something where one stands on top of the other and destroys the other one. Remember: marriage is something that you should enjoy. Let me add one more thing. One must be aware that the reason why you sacrifice yourself for him so much is because he is a person who cannot do what he needs to do. I think you shouldn't marry such a non-independent man in the first place. Living involves many miscellaneous tasks: laundry, cooking, working outside... If your man is somebody who can't do these fundamental things by himself, I recommend you to reconsider your marriage. Perhaps it is better not to marry him."

-----You said that you married because you wanted to escape from your uncle's uncomfortable house. What do you think about that, now?

"I think that was a wrong thing to do. I think doing things 'to escape from the real problem' is not a good thing to do, always. For my marriage, I should have seriously confronted myself asking: 'Am I marrying him because I really like him?'; 'Is it really okay to marry him?' I was aware from the beginning that his actions do not always match with his words. Although I dismissed that behavior at that time, when I recall his behavior of that time, I now want to say to him: 'Get lost!' [Masako laughed.]"

(2) *Tsukushi jidai* [Sacrificing period]

----- Do you have any advice for wives like you, who are trying to perform the perfect housewife role?

“What I would like to ask these people is ‘Aren’t you tired?’ I want them to confront themselves and ask: ‘Aren’t you tired of making such effort?’; ‘Don’t you think you should care more about yourself?’; Are you doing this because you really want to?’; ‘Aren’t you being numb to your feelings.’ And whenever they realize that what they are doing is something they don’t really want to do, I want them to understand that there is the option to ‘stop doing those things that they are not fond of.’”

-----What about woman who wants to stop but can’t because the husband does not allow her to do so? In other words, what should women do if their environment does not allow them to change?

“Well, changing can be very difficult depending on the husband’s character. What should a woman do if she can’t change because of her husband’s character? Should she divorce him? Although it involves pain, it is sometimes better not to divorce him. What we need to do here is to learn how to feel our emotions. Which option is the right thing to do? We must learn how to weigh the possible options and make decisions accordingly. What we must do is to make sure the emotional scale is accurate. If it is broken, we must fix it. It is a very difficult thing to do, you see. This is because many of these women [women who sacrifice and endure the situation] are generally likely to be emotionally numb. They tend to think that they must not feel. But that is not the thing she must do. Those women have to face themselves and have a look straight at themselves.”

(3) *Donzoko-jidai* [the bottom of life period]

-----Do you have any advice for women who are in the same position as yours?

“If you have such a problem in the house, make sure you make a nest egg in order to enable you to run away from the house anytime you want. You can use whatever means. It is important that you secure the money so that you can use it freely. Also, I recommend you to make friends with whom you can talk about your problem. You should not trouble this friend too much in general; but it is important, for example, to secure a place where you can go in case something wrong happens.”

-----Was there anything you sought from public services when you were in the midst of the problem?

“First of all, I think it is important that we are informed about these kinds of problems, the idea that such problems exist in society. Even though you are not interested in the problem at that time, there is a big difference between ‘having heard about it once before’ and ‘not being informed at all.’ Moreover, if you happen to be stuck in such a problem, I want there to be a place where you can gain the necessary information. In general, the first problem these women encounter is that they do not know where they should go for help. Perhaps things may have changed since I was there, but generally even if they go to the public health center, there are seldom useful services for them. The public health center is the place where women commonly go first. I therefore think it would be good if the useful information is all available there. I don’t want to wander from one place to another,

especially when I am in the midst of trouble. I also think it would be good if shelters are easier to access for women, in general. For example, the current women's shelter in this region is not operating 24 hours. You can call them during the day, but in the evening, there is no one who even picks up the phone. So, when a problem occurs, women have to call the police. This system is very inconvenient in case of an emergency. I also think it would be nice if there were more different kinds of self-help groups.”

(4) Now

-----You mentioned Taro's various types of problems such as workaholism, gambling and alcoholism. What do you think was the biggest problem of you two as a whole?

“Our problem is the problem of ‘*kankeisei* [relationship],’ a problem in the nature of our relationship. This is a co-dependence problem.”

Notes: After the interview

When the interview ended officially, I had a conversation with Masako about *jinken* [human right]. Masako is an intelligent and fun person with whom to talk.

“[Masako speaking] I recently understood the true meaning of ‘*jinken*.’ Don't you think the word ‘*jinken*’ is something that appears in a school's textbook? If there is someone who uses this word, people will look at you and asks, ‘Are you a lawyer?’ or something like that.

For a long time, the word *jinken* was something very unfamiliar to me because of its complicated nuance. But *jinken*, in fact, is not something like that...”

----- [I nodded.] It is a simple idea that we are allowed to live as humans, or something like that. [Masako nodded] I have lived in the U.S. for a long time [11 years], and I hear this phrase—basic human rights—quite frequently there. There was a period in my life when I was moved by this concept like you. My understandings of *jinken* went beyond the rigid definition-like understanding and became a simple but very important thing as a human. Honestly speaking, I don’t think there are many Japanese who understand this word like we [or I?] do. In this environment where men commonly work like ants, children struggle in the examination hell but can’t complain, people are tied to various family rules, it is very difficult for this concept to grow in people’s minds. I personally think that the fiercely competitive examination custom which most adolescents, children and sometimes even kindergarten children, must go through in Japan is nothing but a violation of basic human rights! [I laughed but I am half-serious.]

After the chat about *jinken*, we talked about gender and the word feminism. Since Masako appeared as a feminist to me, I asked her if she considers herself so. Unexpectedly, she insisted that she is not a feminist. I told her that the word feminism is misunderstood like *jinken* in Japan; although it simply means people who advocate or fight for gender equality, it has the inappropriate but strong negative connotation. Even so, she still does not want to be called feminist and she seems to be not fond of talking about the subject. Through this, I realized the stronger-than-expected negative connotation attached to the

word “feminism.” This, to me, also indicated the long way there is still to go to improve the current situation regarding alcohol related problems.

Case 8. I want to live at least one year longer than my ex-husband.

Name				Age		Occupation								
Saori Momma				67		Housewife								
Family						Husband's Occupation								
<input checked="" type="checkbox"/> Nuclear		Extended		# of members		4		Salesman in a construction company (retired)						
Family members														
Jiro		Husband		69		Stroke								
Saori		Wife		67		Depression.								
Kazuo		First son				Deceased (car accident)								
Tsugiko		First daughter				Eating disorder, depression.								
Mitsuko		Second daughter		36		Depression								
Yoriko		Third daughter												
Total Interview Time				Wife Attending Self-help Group?				Husband Attending Self-help Group?						
1 hour 30 minutes				<input checked="" type="checkbox"/> Yes No				Yes <input checked="" type="checkbox"/> No						
Wife's KAST concerning her husband's alcohol related behavior (See Appendix 1 on Page 546)														
1	2	3	4	5	6	7	8	9	10	11	12	13	14	Total
<input checked="" type="checkbox"/> 3.7	3.2	<input checked="" type="checkbox"/> 2.3	2.2	2.1	1.7	1.5	<input checked="" type="checkbox"/> 1.2	0.8	0.7	0.7	0.6	0.5	0.5	
-1.1	-1.1	-0.8	-0.7	-0.7	-0.4	-0.5	-0.2	-0.2	0	-0.1	-0.1	0	0	
?	<input checked="" type="checkbox"/> ?	?	?	?	?	?	?	?	?	?	?	?	?	
Analysis (See Analysis on Page 489)														
<input checked="" type="checkbox"/> A1	<input checked="" type="checkbox"/> A2	A3	<input checked="" type="checkbox"/> A4	<input checked="" type="checkbox"/> A5	<input checked="" type="checkbox"/> A6	<input checked="" type="checkbox"/> A7	<input checked="" type="checkbox"/> B1	B2	<input checked="" type="checkbox"/> B3	<input checked="" type="checkbox"/> B4	B5	B6		G1
<input checked="" type="checkbox"/> C1	<input checked="" type="checkbox"/> C2	C3	<input checked="" type="checkbox"/> C4	<input checked="" type="checkbox"/> C5	<input checked="" type="checkbox"/> C6	<input checked="" type="checkbox"/> C7	D1	<input checked="" type="checkbox"/> D2	D3	D4	D5	D6	D7	D8
E1	<input checked="" type="checkbox"/> E2	E3	E4				<input checked="" type="checkbox"/> F1		<input checked="" type="checkbox"/> H1	<input checked="" type="checkbox"/> H2	H3	<input checked="" type="checkbox"/> H4	<input checked="" type="checkbox"/> H5	<input checked="" type="checkbox"/> H6
Types of Problems (See Analysis on Page 489)														
<input checked="" type="checkbox"/> Verbal Abuse		<input checked="" type="checkbox"/> Physical Abuse		Financial		<input checked="" type="checkbox"/> Psychological		<input checked="" type="checkbox"/> Shirinugui		<input checked="" type="checkbox"/> Child-Related				
Note														
Marital Status: Divorced														

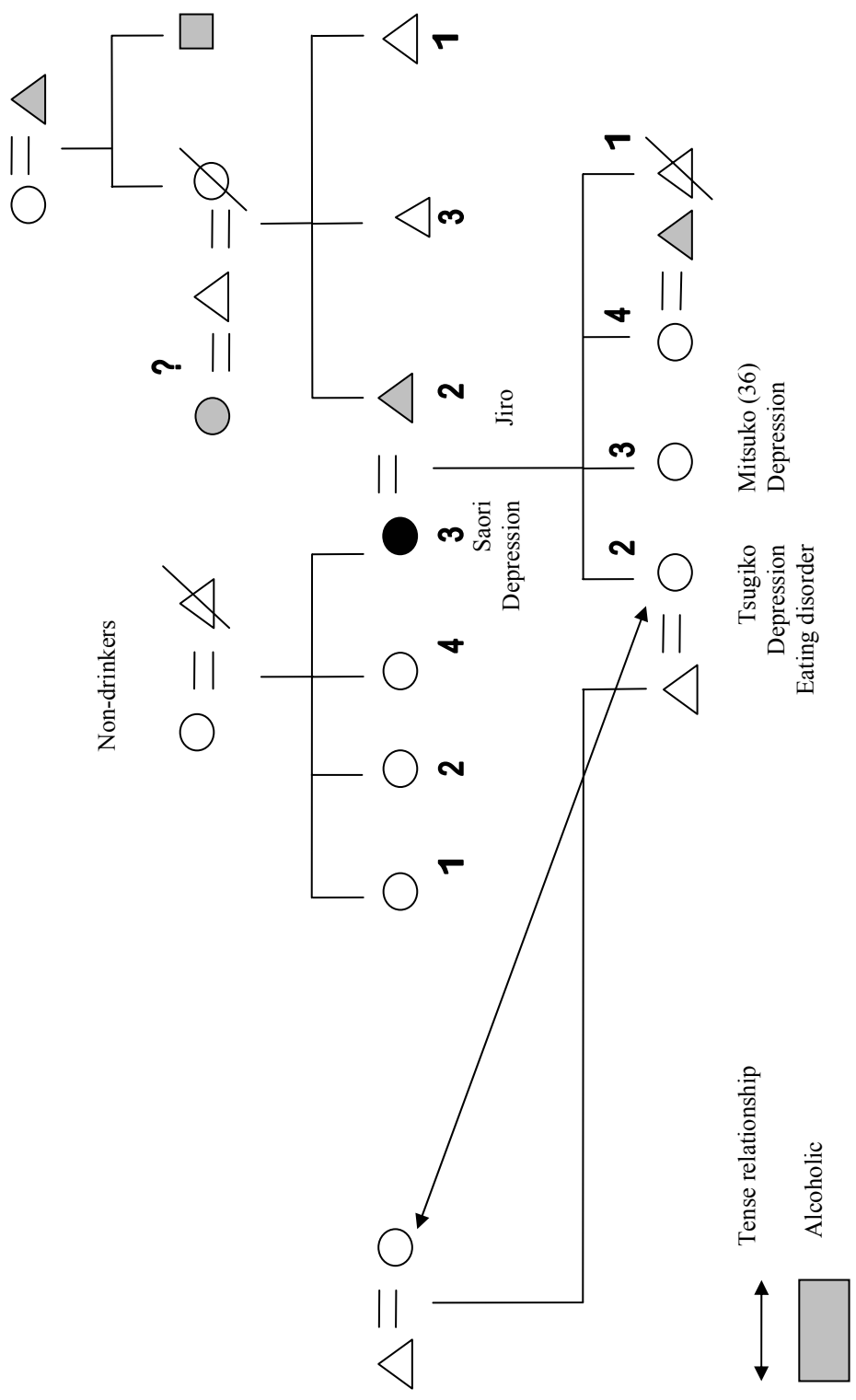

Saori Momma

Saori appears to be a modest person. She speaks carefully and slowly. She appears worn out and seems to have many repressed feelings. She is currently living separated from her ex-husband. In fact, she is having a trial at court with her husband over their divorce and their property [the house, in which the ex-husband is living right now]²². The worn out appearance may stem from the fatigue caused by the trial and the physical fatigue of frequently (weekly) commuting from her daughter's house in Tokyo to here in the Tohoku region.

The beginning of the marriage

After I introduced myself, the study, and the procedure of the interview, Saori started to talk on her own accord.

“I was truly ignorant about this world. One may say that I was raised in too good an environment which made me such an ignorant person. Since neither my father nor my mother drank... I couldn't catch the sign of drinking problems in my future husband's daily behavior.”

Saori repeatedly said “I was ignorant.” and “I didn't have the keen perception of detecting his problem.” during the interview. It sounded like she was trying to make sense of the problem that she went through by blaming herself.

“Jiro had a drinking problem even before our wedding [arranged marriage]. But, because I was so stupid, I didn't recognize that. For example, before our wedding, there was a time when he was living alone in Tokyo where I occasionally visited. One day, when I visited him, he came back

home with blood all over himself. It seems like he drank and fought with his friend. At that time, he pretended that he was a mere victim, saying ‘I didn’t do anything, but he [=his friend] attacked.’ but I don’t think that he was telling the truth when I think of it now. I think he did something to the other person, too. If you don’t do anything, people in general will not beat you up to that extent. Anyway, that’s the story. Because of his violent behavior, I felt uncomfortable with our marriage and decided not to see him for a year. But, I married him after all. I should have turned down his marriage proposal at that time.”

Saori looked down and was silent for a while.

One day during the Bon [Japanese festival of the Dead] holidays

“I still haven’t forgotten the day he badly abused me. I still cannot understand why he abused me. It was during the *Bon* holidays. It was the year my son died.²³”

Saori lost her son in a car accident when he was eleven years old. It is the worst experience of her entire life. Even now, when she recalls her son, big tears come to her eyes. While wiping her tears with her handkerchief, she continued talking.

“He was drinking at that time. I didn’t do anything, but he suddenly started hitting me, and it went on and on. To the children, he yelled, ‘Get back to your rooms!’ Although he commanded the children to go to their rooms, it was obvious to them that he was beating me severely. Jiro hit me over and over again for a while. I really thought I was going to be killed at that time.

²² The trial concluded a few weeks after the interview.

²³ This incident estimated to have happened at the second half of the 1970s.

Afterwards, my face was swollen this big [Saori indicated the size of a basketball in front of her face.] I used to have a *yaeba* [double tooth]²⁴. When he punched my cheek, the tooth cut the inside of my mouth and a lot of blood came from my mouth. After I regained consciousness, I noticed many dark bruises all over my body. My face was very dark and spotty because of the injuries. Because of my shameful appearance, I couldn't leave the house for a month afterwards. The reason of this abuse is still unclear to me now. I try hard to find the reason, but there is really no obvious reason.”

-----Did you go to the doctor afterwards?

“No, I did not.”

Husband's violence

When hearing stories of domestic violence [DV], I occasionally get surprised by the gap between my criteria of DV and the interviewee's criteria of DV. Are my criteria too strict; or are the interviewees too lenient because their feelings are seared? Saori's case illustrates this pattern.

“Jiro's physical abuse was not that bad. [Saori seems to be thinking] It was only that Bon holiday when the violence was very severe. Since he has a lame leg due to an accident when he was little, he mostly yelled at us. Well...but I remember I have been hit by a *bokutou* [wooden sword]. He often overturned the dinner table, too. By the way, I put my sandals at the back entrance so that I can escape from him whenever he drinks and becomes mad. Strangely, I do that even now. [Saori paused.] He often yelled, ‘SHUT UUUP!’ Sometimes he ordered my daughters to sit straight on

²⁴ A tooth growing outside the row of the other teeth.

the floor for a long time. During that time he didn't allow them to eat anything. Sometimes he made them eat when sitting still like that. They ate on the floor! There was no distinction between us and animals such as dogs and cats!"

The cause of husband's problems

-----Do you think the very cause of his problems is in some way related to his disability?

"Yes, I do." [This part was not explored further.]

-----What is the cause of his abuse in general?

"Cause of abuse...? Well, for example, small things could trigger his madness. Just because I ask to turn on the heater, he becomes angry at me. It seems like he really hates doing domestic work."

-----Why do you think he is so abusive?

"One day, I asked Jiro, 'What makes you mad so frequently?' Then Jiro replied, 'Because you are not gentle.' He also said that my character of becoming timid easily is the problem, too."

About Saori

Since the interview started with the topic of domestic violence [DV], I decided to expand on this topic further by using a DV screening test [see glossary on page 555] instead of asking her to

relate her childhood stories, the usual course of these interviews. I asked Saori to answer the questions from the DV screening test and comment freely on whatever comes to her mind.

----Does your husband frequently put you down and say something like ‘You can’t do anything without me.’?

“Yes. He frequently says to me ‘You are a woman who is only good for weeding.’ My house has a little yard, about the size of a cat’s forehead.” [Japanese expression for a small place. Saori is obviously being modest here since I know she lives in a big beautiful house.]

At this point, she started to talk about her husband who is currently living alone in Saori’s house.

“Jiro is living alone right now. He is making my house very dirty. The saying—‘The house of a man who lost his wife will be infested with maggots.’—really applies to him. The dirtiness of the toilet is unbelievable. I told him to wipe the toilet bowl before I visit him the next time, but he didn’t do it at all! There are many places where mold is starting to grow. By the way, the rooms are nothing but a mess! He hasn’t even cleaned the living room! The garden is left like a jungle. Now that it is out of my control, I have to call the professional gardeners to take care of it. [Saori seemed upset.]”

----It seems like your husband can’t even do weeding. [I am saying this ironically.]

“Well, I can’t deny the fact that I am an incapable person. I’m not smart. I wasn’t good at school either. I am also not good at rearranging the house, such as sorting stuff in the drawers and book

shelves. That is how I feel these days. Last time, when I visited the house, I noticed Jiro, who has to leave the house in the near future [because he lost in the trial], completely rearranged the drawers and book shelves in the house. It makes me feel like he is doing this for revenge. He often used to scold me about my inability to sort things in the drawers and book shelves.”

-----You just mentioned that you weren't good at school. Which level of education did you reach?

Saori suddenly ducked her shoulder, looked down, and became silent. Then while shaking her hands, she said:

“No. I really can't answer this question.”

It is possible that she is only a junior high school graduate. This is however not uncommon for the people of her age group and therefore nothing to be ashamed of. I repeated the question one more time, thinking to go to the next question if she refused to answer again.

-----Are you a junior high school graduate?

“N..No. I am just a two-year college graduate. [Given her hesitation to answer the question, I was surprised about her high level of education.] [Saori paused.] But Jiro often said to me, that my degree is just an extension of the kindergarten degree.”

About Jiro

I asked her about Jiro's educational history, occupation, and personality.

-----What kind of person is Saori's husband?

“He is a university graduate and an engineer at a business firm affiliated with the S group. From outside, he appears to be a very capable worker. Someone once mentioned that he was like a ‘human bulldozer.’ He was working at the sale’s division of that company.”

-----There are many men in Japan who work at the sale’s division because they can maintain a solid character even if they drink and get drunk. Was your husband allocated to that division because of this character?

“No. I don’t think he worked there because he had such a character. Jiro was capable of drawing a house’s blueprint very fast. Such ability is crucial for his work. [Saori paused] Because of that character, I think he had many enemies at the workplace.”

-----Has he ever caused trouble with people because he was drunk?

“Once he flew into a rage and quarreled with his boss. The next day, I visited the boss’s place with a present and apologized for my husband.”

Since his retirement, Jiro has been indulging himself with drinking, smoking, and playing go [Japanese chess] without limit. His alcohol problem hasn’t been properly treated. He has not attended self-help group meetings either.

“One day, he had an infarction at the brain [stroke] and thus went to see an internal medicine doctor. The doctor asked Jiro, ‘Do you drink alcohol?’ He replied, ‘Somewhat.’ Then the doctor asked him again, ‘Some or what? A lot?’ [Saori laughed] I was curious how he is going to reply to this question at that time. Then he answered, ‘Some’ after all. I couldn’t believe it! How could he say such a lie right in front of me?! [Saori looked upset.]”

-----Do you think you can get along well with Jiro if he doesn’t resort to violence because you believe that he is in nature a very good person?

“Well, [Saori looked as she was thinking and talked slowly.] I don’t think his nature is good in the first place. I think his original personality itself has a serious problem. [I.e. I don’t think I can get along with him if he just becomes non-violent.]”

The daughters

It is commonly believed that a bad marital relationship negatively affects the children’s life, too. This pattern applies to Saori’s children as well.

“These experiences negatively affected my children who currently suffer from various diseases. I am occasionally blamed by them for the family environment.”

According to Saori, all her daughters suffer from depression. One is suffering from an eating disorder, too. The direct reasons of their diseases are the bad relationship with her mother-in-law for the oldest daughter, problems at her workplace for the second daughter, and her alcoholic

husband for the third daughter. Saori however believes that their horrible experiences in the past are the root of their problems.

“Right now, Tsugiko (second daughter) is suffering from a bad relationship with her mother-in-law. While suffering, her childhood and adolescent memories come up in her mind like a trauma which puts her into serious depression. It is me who created her character of always feeling doomed about the future by only thinking about the negative outcomes in the future.”

Throughout the interview, I noticed Saori’s strong feeling of guilt towards her children. She doesn’t give excuses nor justifies herself for her wrongdoings. The feeling of guilt is evident in Saori’s repetitive words expressed throughout the interview: ‘It was my fault’; ‘It was because of my stupidity’; and ‘The fault is due to my ignorance.’ She talks about Tsugiko, who is going through depression as well as an eating disorder, as follows:

“She is a gentle and an excellent daughter. Despite the fact that I made her go through such horrible experiences, she still gives me a present and a card saying ‘I wish you a good health and a long life,’ on my birthday.”

Desire to Suicide

Saori suffers from depression, too.

“I am staying at my daughter’s small apartment in Tokyo right now. At the veranda, there is a long loft pole [Saori gestures a water pipe thick long pole with her hands] at the ceiling. When I see it, I sometimes think, ‘I may use it, and just do it.’”

With a worn out face, she smiles sadly. She was more than half serious.

----- What do you mean by ‘do it’? Do you want to kill Jiro or your daughter? [I understood what she meant, but I pretended that I didn’t understand because I didn’t know how to react to her statement.]

“No, not murdering. I mean killing myself.” [Saori smiled a little bit.]

The tension was gone. Saori pulled herself together and continued talking.

“But, if I commit suicide or kill Jiro, the damage is too big for the children. I can’t let them become the children of a murderer. I must never let them live with such a stigma for rest of their lives.”

Although she is suffering, Saori is always concerned about her children, sometimes more than with herself.

“Recently I encouraged myself by saying to myself, ‘I am not going to lose against that guy. I will not give up. This pain is nothing.’ And for this, I say to myself, ‘I will overcome my depression.’ These days, I sometimes wonder how long I can live from now. What I strongly think is that I want to live at least one year longer than my husband and enjoy the time.”

Marriage

-----Looking back, how do you think about your married life? How did your perspective about marriage change from before you married and now that you divorced him?

“[Saori answered slowly.] Before the marriage, I used to have an idea that ‘without being married, you are not a real woman.’ Because of this, I used to think I must get married, and thus got married. The reality of my married life was a mess. I had not needed to go through this unnecessary pain if I hadn’t married. Right now, I strongly believe that ‘marriage is not everything.’”

Divorce

Saori once ran away from the house when she was still young. At that time, the reasons which led her to not divorce Jiro were financial reasons and the anxiety of not being able to cope with the miscellaneous tasks that come along with divorcing her husband (e.g. changing children’s school, filing documents for divorce etc.). She therefore decided to remain in the house, which made her suffer afterwards for a long time. During that period, she suffered from constant headache and dizziness.

About ten years ago, she consulted a doctor about her problem and started to attend self-help group meetings. Since then, she has learned much about alcohol related problems. The doctor often advised her to divorce Jiro. Some of her self-help group’s acquaintances also told her, ‘You are still with him? Get separated!’ whenever they met her. However, for Saori, to divorce Jiro was not so easy. As described above, financial factors and her inability to go through the legal procedure for divorce and also property related problems were the strongest concerns against divorce. But things are different now. This time, she withdrew the money from her

husband's bank account and left the house with it. She also fought with her husband in court over the divorce and the property. As described by Saori, too, the horrible married life with Jiro seems to have changed her character from subordinate and passive to strong and determined.

Trial

Until recently, Saori was busy with the trial to win back her house as well as making Jiro leave it. The house Saori and Jiro used to live in was originally Saori's parents' house. Saori's father, who was unaware of Jiro's terrible character, gave 3/4 of the property to Jiro and 1/4 to Saori on the occasion of their marriage. Now that they want to get divorced, the problem is that most of the property officially belongs to Jiro. Moreover, Jiro is staying in the house, her parents' house. Saori believes that this house belongs to her. In order to regain her parents' house, Saori decided to go to court. For over a year, from their separation until the trial was decided, Saori lived with one of her daughters in Tokyo and came all the way to the Tohoku region every time something needed to be taken care of in this matter.

“Thank you for allowing me to talk about my problems”

Despite her weary face, Saori shared many things about herself throughout the interview. When we finished and were about to leave the room together, she bowed deeply and said:

“Today, I was able to do *jinsei no sentaku* [the cleanings of my life]. Thank you for allowing me to do this.”

I was surprised with her humble words and replied back:

----- Oh, no. It is rather me who wants to thank you for telling me about your life.

Filing a divorce in one's late sixties is quite a radical decision. She, however, did it because she thought that it was still worth it.

Case 9. Since I became aware of his alcohol dependence problem, my life became a lot easier.

Name					Age		Occupation								
Noriko Suzuki					41		Housewife								
Family					Husband's Occupation										
<input checked="" type="checkbox"/> Nuclear			Extended		# of members		4		Police officer						
Family members															
Ichiro		Husband			43										
Noriko		Wife			41										
Kazuko		First daughter			15										
Tsugie		Second daughter			6		Physically disabled (car accident)								
Total Interview Time					Wife Attending Self-help Group?					Husband Attending Self-help Group?					
First: 2 hour 20 minutes Second: 30 minutes					<input checked="" type="checkbox"/> Yes No					Yes <input checked="" type="checkbox"/> No					
Wife's KAST concerning her husband's alcohol related behavior (See Appendix 1 on Page 546)															
1	2	3	4	5	6	7	8	9	10	11	12	13	14	Total	
<input checked="" type="checkbox"/> 3.7	<input checked="" type="checkbox"/> 3.2	<input checked="" type="checkbox"/> 2.3	<input checked="" type="checkbox"/> 2.2	<input checked="" type="checkbox"/> 2.1	1.7	1.5	1.2	0.8	0.7	<input checked="" type="checkbox"/> 0.7	<input checked="" type="checkbox"/> 0.6	0.5	<input checked="" type="checkbox"/> 0.1	13.6	
-1.1	-1.1	-0.8	-0.7	-0.7	<input checked="" type="checkbox"/> -0.4	<input checked="" type="checkbox"/> -0.5	<input checked="" type="checkbox"/> -0.2	<input checked="" type="checkbox"/> -0.2	<input checked="" type="checkbox"/> 0	-0.1	-0.1	<input checked="" type="checkbox"/> 0	0		
?	?	?	?	?	?	?	?	?	?	?	?	?	?		
Analysis (See Analysis on Page 489)															
<input checked="" type="checkbox"/> A1	A2	A3	A4	<input checked="" type="checkbox"/> A5	<input checked="" type="checkbox"/> A6	<input checked="" type="checkbox"/> A7	<input checked="" type="checkbox"/> B1	B2	<input checked="" type="checkbox"/> B3	<input checked="" type="checkbox"/> B4	<input checked="" type="checkbox"/> B5	<input checked="" type="checkbox"/> B6	G1		
<input checked="" type="checkbox"/> C1	C2	C3	C4	<input checked="" type="checkbox"/> C5	<input checked="" type="checkbox"/> C6	<input checked="" type="checkbox"/> C7	D1	D2	D3	D4	D5	D6	D7	<input checked="" type="checkbox"/> D8	
<input checked="" type="checkbox"/> E1	<input checked="" type="checkbox"/> E2	E3	<input checked="" type="checkbox"/> E4				<input checked="" type="checkbox"/> F1	<input checked="" type="checkbox"/> H1		<input checked="" type="checkbox"/> H2	H3	<input checked="" type="checkbox"/> H4	H5	<input checked="" type="checkbox"/> H6	
Types of Problems (See Analysis on Page 489)															
<input checked="" type="checkbox"/> Verbal Abuse			<input checked="" type="checkbox"/> Physical Abuse			Financial			<input checked="" type="checkbox"/> Psychological			Shirinugui		<input checked="" type="checkbox"/> Child-Related	
Note															

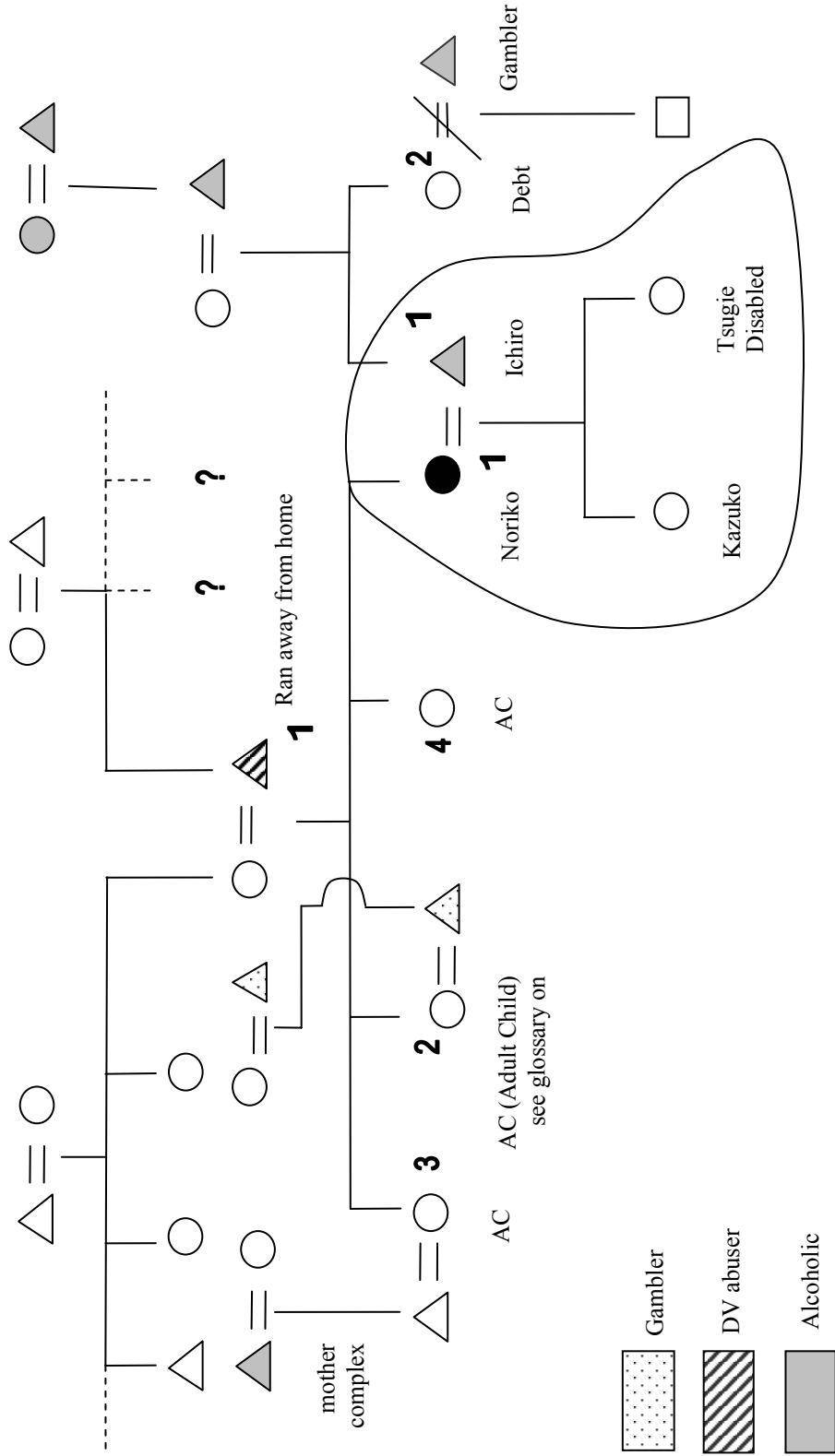

Noriko Suzuki

Noriko is a good looking woman. Her way of speaking is logical and clear, which suggest to me a firm character. I have heard from another source that her husband is also like her—good looking with a firm character—which is far from the stereotype of alcoholics' character.

***Kateinai-rikon* [Divorce within the household] and Noriko and Ichiro's family**

background

Noriko seemed nervous at the beginning of the interview. While there are interviewees who were eager to talk about their domestic violence experiences right from the beginning, this did not apply to Noriko and I therefore thought asking about it would be inappropriate, especially at the beginning.

-----May I ask you about your family background, first?

It appeared to me that talking about her family background was already troublesome for her. She started talking.

“Um... I must say one thing first... Um... our relationship as a married couple is already broken. There is absolutely no confidentiality anymore between us as husband and wife. Like it happens to many relations which involve an alcoholic, we cannot distinguish ‘what to say’ from ‘what not to say.’ We have lost a normal value system; we say many rude things to each other without any restraint.”

I asked Noriko not to feel obligated to talk about things she felt uncomfortable sharing. It was important that she knew that she could and should deny answering questions she did not want to answer. Although she showed nervousness and a conservative attitude at the beginning, she spoke about various things in her life as the interview progressed.

Noriko grew up in an environment where her father abused family members, especially her mother. This father, who was also an oldest son in his family, ran away from home when he was young. According to Noriko, all her siblings including her are adult children [AC, see glossary on page 554]. One married a man who is a gambling [pachinko] addict, another one married a *mazakon* man (abbreviation for *mazaa-komprekkusu* [mother complex, a man who is abnormally attached to his mother. Oedipus complex.]). The *mazakon*'s man's father is an alcoholic. Ichiro's family background involves many alcoholics. At least from the great-grandparents' generation, she can point out several problematic drinkers in the family. Her husband's sister divorced a man who had gambling [horse race], alcoholism, and debt problems.

“I come from a domestic violence family and he comes from alcoholism family. Perhaps, therefore, we were destined to come together.”

Daughters

Noriko is a housewife. Her oldest daughter, Kazuko, is currently fifteen years old preparing for high school entrance examination . Her second daughter, Tsugie is six years old. Since she became disabled in a car accident of few years ago, Noriko takes her to a kindergarten for disabled children every day. At this point, the prospect of the future of the Tsugie's physical

disability is undecided. With one daughter preparing for an exam and the other one disabled, her current life appeared to me as quite stressful.

-----Your task as a housewife sounds quite rough compared to that of other housewives.

“Yes, it is. [Noriko paused.] But, if I was able to do something more than just a housewife, I wouldn’t be so humiliated by my husband who accuses me saying things as ‘You can’t even do cleaning.’ My husband is a police officer [relatively high rank] whose status is guaranteed by society. I, on the other hand, don’t have anything like that. I regret my ignorance for not putting importance in career at all.”

When she was young, Noriko failed the entrance exam to enter high school. She had to go to a vocational school instead and spent four years there. After she graduated from there, she became an *OL* [Office Lady] until she married Ichiro.

“Perhaps I will regret failing the exam to enter high school for the rest of my life. I don’t want my daughter to fail the examination like I did. I say many such things to Kazuko every day. While I say these things, I sometimes feel like I am talking to myself and not to her. I think I really don’t want her to repeat my mistakes, the failing experience that I regret a lot.”

Decrease of burden since she understood that her husband is an alcoholic

Throughout the interview, Noriko emphasized that her life became a lot easier after she learned that Ichiro has alcohol dependence syndrome. The knowledge about the disease gave her a new perspective in various ways.

“For me, knowing that he has alcohol dependence syndrome led to my recovery in various ways. When I was told that he is alcohol dependant, I was honestly very relieved. Since then, I started looking for more information about this disease and became aware of my AC problem, too. It wasn’t only him, but also me who had a problem. Until then, I was always worrying not to hurt Ichiro’s sensitive feelings and giving priority to his life instead of mine. For example, we visited his parents much more often than mine. Although I was not happy about this, I was following him without complaint since I thought ‘He is working and earning money while I am just a housewife not earning money.’ But now, I don’t think like that any more. I now think that behavior is the behavior of people who can’t put importance in their own feelings, people who can’t properly take care of themselves.”

Husband’s problem drinking

Noriko expressed that she did not notice her husband’s drinking problem at the beginning of their marriage.

“I was incapable of seeing drinking problems. Since I grew up in a non-drinking family, I wasn’t aware of any signs which indicate the potential future alcohol problems. I was surely informed that he does *banshaku* [drinking with meal, see glossary on page 554] every day. But I didn’t think that was a problem at all at that time. I was ignorant. I knew nothing about the world. Nothing...”

Noriko says that the drinking problem existed already at the beginning of their marriage.

“Thinking back, there were alcohol problems from the beginning of our marriage. He did banshaku every night. Considering his health, he once decided to have two *kyukanbi* [resting day for one’s liver, no drinking day, see glossary on page 556] per week, but he couldn’t keep the promise. So he decided to do once per week, but he couldn’t even do that. From that time on he had diarrhea and he still has it now. One day, our doctor told me that this is probably one of the symptoms of his alcohol dependence syndrome, his habit of drinking too much.”

-----When did you start thinking that your husband is an alcoholic?

“I think it coincided with the time Tsugie became disabled. His drinking habit became severe from that time. That was about 4 years ago.”

Considering the fact that Noriko married Ichiro at the age of 26 and she noticed his drinking problem 4 years ago, it took more than ten years for her to consider him an alcoholic from the time she first noticed his alcohol related problem.

Verbal Violence

Noriko considers her husband’s verbal abuse most painful.

“There is almost no physical violence. But he verbally abuses me almost every single day. For example, my husband is a very tidy person. So he says things like ‘You can’t clean the house,’ ‘You can’t even clean the house,’ ‘Perhaps you have ADHD problem [Attention Deficit Hyperactivity Disorder—one of the symptoms is being incapable to make ones surroundings neat and clean], ‘You are cleaning the square room round.’ Every day he says: ‘You are

incapable of cleaning.’ He complains about the way I close the curtain. When it comes to curtains, [Noriko paused and tried to calm down] he makes me fold the curtain like origami [Japanese paper folding], 20 cm wide back and forth neatly like this [Noriko uses her scarf and folds it very neatly]. If I don’t follow his words, he gets angry and puts me down, makes me feel that I am nothing. [Noriko paused.] Since he is so strict on me, it makes me wonder what kind of clean environment he was brought up in. I have been to his parents’ house, and it really makes me wonder; I think his parents’ house is worse than my house [Noriko tilted her head sideways and looked doubtful.]. He says, ‘You are dull-witted and slow. That is the reason why I say dumb to you all the time.’ He once said to me ‘Your eyes are like a rotten fish’s eyes.’ This really hurt me since one of my eyes has low eyesight and therefore I am a bit squint-eyed [this problem was almost unnoticeable to me]. In addition, I was brought up in a fishing village where my father worked as a fisherman. My husband does not step on the edge of the *tatami* mats and I on the other hand do. He therefore criticizes me saying, ‘Your family did not even teach you such basic manners. That’s the reason why you can’t properly educate your children either.’ Sometimes Kazuko goes against him. Whenever this happens, he accuses me of not properly raising the child. There was a time when he drank and came to my bedroom. I was of course sleeping, but he criticized my faults drunkenly for ever and ever. Yesterday, too. Just because the evening meal—sausage—was a bit too spicy for him, his complaint went on and on...”

-----Has he ever hit or kicked the wall, overturned the dining table, or thrown things at you?

“No, he never did that. You see. For my husband, the house is the most precious thing in the world. He is obsessed with keeping it neat and clean, almost to the extent of abnormality. He

easily gets mad when the house is damaged. One day, I fell in the bathroom and bled. He came right away saying ‘Ohhhh, my house!’ instead of caring about my wound. Every time something happens to the house, always says the same: ‘Don’t destroy my house. It is a thirty year mortgage!’ So here I am, always worrying about my husband scolding me about taking care of the house. When Tsugie was still small, I was obsessed with the idea that she should not make any damage to the house. I was always worrying about her behavior and telling her not to damage the house....”

-----Does your husband try to watch your movements such by calling you frequently and check where you are or what you are doing?

“He used to do that frequently in the past. It was the worst before I noticed that he is alcohol dependant. Without my consent, he opened my bag and checked the contents. He frequently called and asked me what I was doing, too. There were times he was eavesdropping on my telephone conversations with my friends, too. One more thing about the phone call... One day, an old friend called me. Since I haven’t seen her for a long time, our conversation went on for a while, perhaps for thirty minutes or so. Next time I noticed, Ichiro was standing right next to me shouting ‘How long do you have to talk!’ He said it so loud that my friend heard it, too. I couldn’t believe what he was doing. I was very angry afterwards. Since then, my friend says ‘It’s scary to call Noriko’s house.’ and calls me only during the day. It is such a sad and deplorable thing to happen.”

Physical violence

Ichiro used physical violence against Noriko only once. When I asked about the reason, she answered:

“I was struck or knocked by my husband only once. It happened a while ago when I was worried about my husband’s drinking problem, and thus was deeply involved in self-help group activities, such as participating in the weekly meetings and going to public lectures and so on. It seems that my husband didn’t like that. One day, saying that ‘I went the wrong way,’ he struck at the back of my head, bang [Noriko pointed her head’s occipital region] like that once.”

Deviant behavior

While Ichiro’s abusive words hurt her heart, she on the other hand did not have a chance to heal the wound. As time passed by, her bottled-up feelings accumulated and transferred into deviant behavior.

“In worst case, I took sleeping pills to go to sleep. Sometimes, I banged pots and pans with lids and utensils and made loud noises in order to release stress. While cooking or cleaning the house, I use ear plugs, too. Cleaning, for example, easily takes thirty or forty minutes. I hate my husband complaining about various things and disturbing my work. I don’t want to hear his complaints any more, at all. That is why I wear ear plugs. My problem went to the extent that I can no longer distinguish what is normal from what is abnormal. [Noriko paused.] Since I also have a disabled child, I used to panic frequently, especially before knowing that my husband is alcohol dependant. Before knowing about his problem, I went crazy every time he accused me.

I didn't understand what was going on and therefore did not know what to do. I was desperate. There was a time I could barely stand up on the floor. I felt like I was floating in the air sometimes."

She confessed that the bottled-up feelings led her to abuse her child.

"I am sorry for my daughter, but I abused her. Since I grew up in a family of domestic violence, I have always thought not to become a physically abusive parent. But I occasionally noticed that I was beating my child in the name of 'raising' the child.' It was not 'raising' but rather hitting the child according to my will. I didn't hit her head, but I hit her hands and her butt based on my emotions. Since I wasn't aware of my AC problem at that time, I wasn't aware of my deviant behavior either."

The oldest daughter's behavior

It appears that the oldest daughter is also negatively affected by her father's drunken behavior.

"Kazuko also couldn't tolerate the situation, so we asked a company to attach a lock to her room's door. [Noriko paused.] Hearing that I put a lock on my adolescent daughter's room's door, you might think 'why in the world am I doing that as a parent?' In our house, however, we must do so. My husband also often complains to Kazuko. Just because her bath was a bit long, for example, he scolds her more than necessary. Sometimes, without notice, he enters her room and drunkenly tries to make his point. He says many nasty things that cause distrust in people, such as 'You are sly,' 'You are a liar,' etc. I don't want Kazuko's precious life to go the wrong way just because of Ichiro. The reason I use ear plugs or put a lock on her bedroom

is that I want her to pass the entrance exam for high school, a milestone in her life and a great challenge, without unnecessary additional obstacles.”

It seems that Kazuko is scared of her father when he is drunk.

“Sometimes, late at night, when I am sleeping in my bedroom upstairs, my daughter knocks the door and asks me to accompany her to go downstairs. She asks, ‘Urr, Mom [hesitant tone]? I want to go downstairs to the kitchen, but dad is there, drinking. Could you please come with me to the kitchen?’”

She hates it when her friends talk anything about alcohol.

“Sometimes, among her friends, they talk about alcohol related issues such as one saying ‘my dad is drinking all the time these days.’ When such occasions occur, she feels uncomfortable and wants to change the topic or leave as soon as possible.”

The cause of husband’s drinking

What does Noriko think is the cause of her husband’s drinking?

“In the past, I used to think that the stress from his work was the cause of his excessive drinking. About his daily criticism and complaints, I thought, ‘Perhaps he was venting his stress on me by scolding or criticizing me.’ But since I learned about the nature of alcohol dependence syndrome, I changed my perspective. An elderly woman whom I meet at the self-help group meeting once said something like this: ‘You don’t become an alcoholic just because

you like drinking. There is more than just liking the alcohol. The problem is in the family environment where he grew up; the root of him is the part that is rotten. There is something that makes him drink.’ When I heard this, I was convinced. Her reasoning made more sense to me than my work-related stress hypothesis.”

Poor husband

Noriko, who is calm at the moment, talks about how she sees her husband objectively.

“So, because of this, I sometimes have sympathy for him, thinking that ‘He is also the poor victim [not merely the wrongdoer].’ But that is when I am calm... When I am in the midst of the problem, my feeling towards him is nothing but anger and is far from what I just said right now...”

If only he didn’t drink...

-----Do you think you can get along with him if he stops drinking?

“That’s a difficult question. [Noriko appeared to be thinking hard.] You see, people at the self-help group say something like ‘Alcoholics are originally very good people.’ or ‘Alcoholics became alcoholics because they were too good men originally.’ But, I can’t think in that way. My negative image of him is too strong. I can’t think ‘I could get along well if only he didn’t drink.’ or ‘he is originally a very good person and therefore became an alcoholic.’ I tend to think that ‘he is bad from the very beginning, from the root.’ Perhaps I am lacking in the effort I should make...”

The current married life: *kateinai-rikon* [divorce within the household]

The present husband-and-wife relationship is the relationship of water and oil—they repel each other strongly. Noriko rarely does anything together with her husband, for example visiting her parents.

“My love towards him cooled down completely. Right now, I think ‘as long as our life is running, that is enough for me.’ Probably Ichiro regards me as the worst woman in the world.”

She continues.

“One day, a person at the self-help group meeting told me: ‘The alcoholic’s marital relationship is like ‘less than zero points in an examination. It is negative since people’s relations with others generally do not involve hatred.’ When I heard this, I thought my marital relationship is ‘less than zero points,’ too.”

Noriko’s dream she held towards marriage and the reality

Noriko married Ichiro at the age of twenty-six through the introduction of an acquaintance.

“I don’t know what young people do these days, but at that time, when I was young, it was

normal for a woman to work and get married. There was an idea that woman should get married by the age of twenty four or five. So, as I was part of that trend, I married Ichiro.

Thinking back, I think it was very wrong. I think so since I married him without thinking about the purpose/meaning of marriage or the purpose/meaning of having a child. It was like a child giving a birth to a child... I don’t think I was qualified to become a mother at that time.”

-----Before getting married, what dream did you have of married life? How do you think about that now, after you experienced the reality?

“I used to believe that married relationship is a relationship of mutual trust. I therefore wanted to make a relationship in which both trust each other. A relationship where one can talk about everything... That was my idea. Unfortunately, however, confronted with reality, I learned that what I used to think was just an illusion.”

Divorce

-----Have you ever considered divorcing your husband?

“I ran away from the house once. I went to my parents’ house at that time. But, considering the situation of the disabled child, I had to come back. It would have been great if I could make the decision at once, but I can’t. I have been unable to make the decision and prolonged my current life by halves until today... [Noriko paused.] One day, I couldn’t tolerate his drinking problems and then the idea of divorcing him struck me. I went to see a lawyer at once. The lawyer’s [male] response was however unexpected. He told me, ‘You must become wiser. Your depressive behavior makes not only your husband but also me upset about you.’ When I was told so, I cried and cried, feeling that I was not properly understood. I heard later that there are specializations among lawyers. The lawyer I consult was not a divorce specialist.”

It has been pointed out that many women who ask for help in these kinds of domestic problems confront indifference from the officers involved. Yoshihama (1999) reports some insensitive

remarks made by the Japanese judicial system's family court conciliators: "You should consider one or two slaps as a sign of love and passion and accept them," "You have tolerated your husband's violence for 20 years and had children. How come you cannot tolerate it any more?" "Women should endure," "You are too stubborn as a woman. That's why your husband dislikes you." (Pp. 78-79)

Ichiro's understanding of his drinking problem

How does Ichiro understand his drinking problem? I wondered if there is any positive sign for the future.

"My husband denies his problem, saying 'I'm not alcohol dependant.' and therefore doesn't go to the self-help group meeting."

-----How about you? Do you go to the self-help group meeting?

"I am not going there for the time being. It's because my daughter is currently preparing for the entrance exam... In addition, I am busy taking care of my second daughter... I really want to go, though. But if I go, I think there will be various things I want to do further, such as going to public lectures, participate in a fun events... These are not good for me right now. I should refrain from all these. I am thinking to start going there again after Kazuko's examination, though. Sometimes I feel like me behaving like this is part of my co-dependence problem.
[Noriko smiled]"²⁵

-----[I said involuntarily.] Don't you think it is especially important for you to go to such places right now since you are going through a difficult time? Although it is not manageable to go there every day, I don't think it would hurt you much if you go there, say once per month or so.

“Yes...I think you are right. As a matter of fact, currently, during the spare time caused by the reserved lifestyle, I watch unnecessary TV shows, some garbage shows about entertainment and politics. Those are even less important than going to the meeting for me anyway...”

Shizuka na aruchu [quiet alcoholics]

When the interview approached the end, Noriko related several stories which have been concerning her for a while.

“Um...I have a question. I have a friend whose husband drinks every day from the morning. Isn't this considered alcoholic? Well my problem is that she says that she has no problem like the problems I have. She says that her husband doesn't have any problem at all. I wonder if she is hiding her problem, enduring it, or being senseless, meaning she cannot feel that there are problems. What do you think about this kind of person?”

²⁵ For the explanation for non-Japanese reader: Many Japanese mothers make great efforts for their children's entrance exams. Noriko's behavior is common, nothing unusual among Japanese mothers. (From my personal perspective, however, the social phenomenon of many Japanese mothers making significant efforts for their children and pursuing their dreams through their children's accomplishments of passing the exam appears unhealthy not only for the children but also for the women.)

She was talking about the type of alcoholics described by Inada Nada in his “*shizuka na aruchu* [quiet alcoholics] hypothesis.” As confirmed by the data of this study, this type of alcoholics exists in Japanese society. They are the ones who receive medical treatment not because they suffer from alcohol related societal or domestic problems, but because their alcohol related physical or psychological disorder worsened to the extent that they cannot endure the situation anymore. Some of them die without ever undergoing proper treatment for alcohol dependence syndrome.

The society’s closed attitude to the problem of alcoholism

Noriko also pointed out the trend of the society to be closed to the problem of alcoholism.

“Sometimes when I say ‘My husband has alcohol dependence syndrome,’ some people’s immediate responses is, ‘Oh that is a family disease. It means that you also have a problem.’ It makes me feel like there is a fault in me and that discourages me to speak any further. In addition, alcohol dependence syndrome is a hard topic to talk about. I wish Japan were generally more open about this kind of problem. In other words, I wish we could talk about this kind of issue more freely without stigma attached to it for being a member of the alcoholic family.”

Noriko’s tears

Since Noriko had been talking spiritedly, I was busy taking notes based on her stories. Once when I happened to look at her while I was writing, I noticed she was suppressing her tears yet many of them were falling down in big drops. I realized the pain hiding behind her cheerful and firm character. Things are not fair for her; her pain is not due to her own faults. It is also

uncontrollable. In the field of alcohol related treatment, telling survivors “*ganbatte* [please make an effort. A common Japanese phrase to encourage a person to work hard.]” is usually a taboo thing to say. But since I feel so much for her, I would like to convey the following message to her: “Although your burden is overwhelming, please don’t give up. Please overcome the difficulties. There is always something good in life and that is what you have to look for...”

Case 10. Husband's *amae* and gender within the household

Name		Age	Occupation												
Kimiko Toyota		58	A full-time worker at a famous regional long-established confectionary store												
Family			Husband's Occupation												
Nuclear <input type="checkbox"/> <input checked="" type="checkbox"/> Extended		# of members	5	Various places such as convenience store, a famous regional long-established confectionary store, restaurant (currently unemployed)											
Family members															
Ichiro	Husband		62	Diagnosed with character disorder/abnormal character											
Kimiko	Wife		58												
Kazuo	First son														
Tsugiko	First daughter														
Masazo	Ichiro's father			Deceased											
Hatsu	Ichiro's mother			Deceased											
Total Interview Time			Wife Attending Self-help Group?					Husband Attending Self-help Group?							
3 hour 50 minutes			<input checked="" type="checkbox"/> Yes <input type="checkbox"/> No					Yes <input type="checkbox"/> No <input checked="" type="checkbox"/>							
Wife's KAST concerning her husband's alcohol related behavior (See Appendix 1 on Page546)															
1	2	3	4	5	6	7	8	9	10	11	12	13	14	Total	
<input checked="" type="checkbox"/> 3.7	<input checked="" type="checkbox"/> 3.2	<input checked="" type="checkbox"/> 2.3	<input checked="" type="checkbox"/> 2.2	<input checked="" type="checkbox"/> 2.1	<input checked="" type="checkbox"/> 1.7	<input checked="" type="checkbox"/> 1.5	<input checked="" type="checkbox"/> 1.2	<input checked="" type="checkbox"/> 0.8	0.7	<input checked="" type="checkbox"/> 0.7	<input checked="" type="checkbox"/> 0.6	<input checked="" type="checkbox"/> 0.5	<input checked="" type="checkbox"/> 0.5	20.8	
-1.1	-1.1	-0.8	-0.7	-0.7	-0.4	-0.5	-0.2	-0.2	0	-0.1	-0.1	0	0		
?	?	?	?	?	?	?	?	?	?	?	?	?	?		
Analysis (See Analysis on Page 489)															
<input checked="" type="checkbox"/> A1	<input checked="" type="checkbox"/> A2	A3	A4	<input checked="" type="checkbox"/> A5	<input checked="" type="checkbox"/> A6	<input checked="" type="checkbox"/> A7	B1	<input checked="" type="checkbox"/> B2	<input checked="" type="checkbox"/> B3	<input checked="" type="checkbox"/> B4	<input checked="" type="checkbox"/> B5	<input checked="" type="checkbox"/> B6	<input checked="" type="checkbox"/> G1		
<input checked="" type="checkbox"/> C1	<input checked="" type="checkbox"/> C2	C3	C4	<input checked="" type="checkbox"/> C5	<input checked="" type="checkbox"/> C6	<input checked="" type="checkbox"/> C7	<input checked="" type="checkbox"/> D1	D2	<input checked="" type="checkbox"/> D3	D4	<input checked="" type="checkbox"/> D5	<input checked="" type="checkbox"/> D6	D7	D8	
<input checked="" type="checkbox"/> E1	<input checked="" type="checkbox"/> E2	<input checked="" type="checkbox"/> E3	<input checked="" type="checkbox"/> E4				<input checked="" type="checkbox"/> F1	<input checked="" type="checkbox"/> H1		<input checked="" type="checkbox"/> H2	H3	<input checked="" type="checkbox"/> H4	<input checked="" type="checkbox"/> H5	H6	
Types of Problems (See Analysis on Page 489)															
<input checked="" type="checkbox"/> Verbal Abuse		<input checked="" type="checkbox"/> Physical Abuse			<input checked="" type="checkbox"/> Financial			<input checked="" type="checkbox"/> Psychological			<input checked="" type="checkbox"/> Shirinugui		Child-Related		
Note															

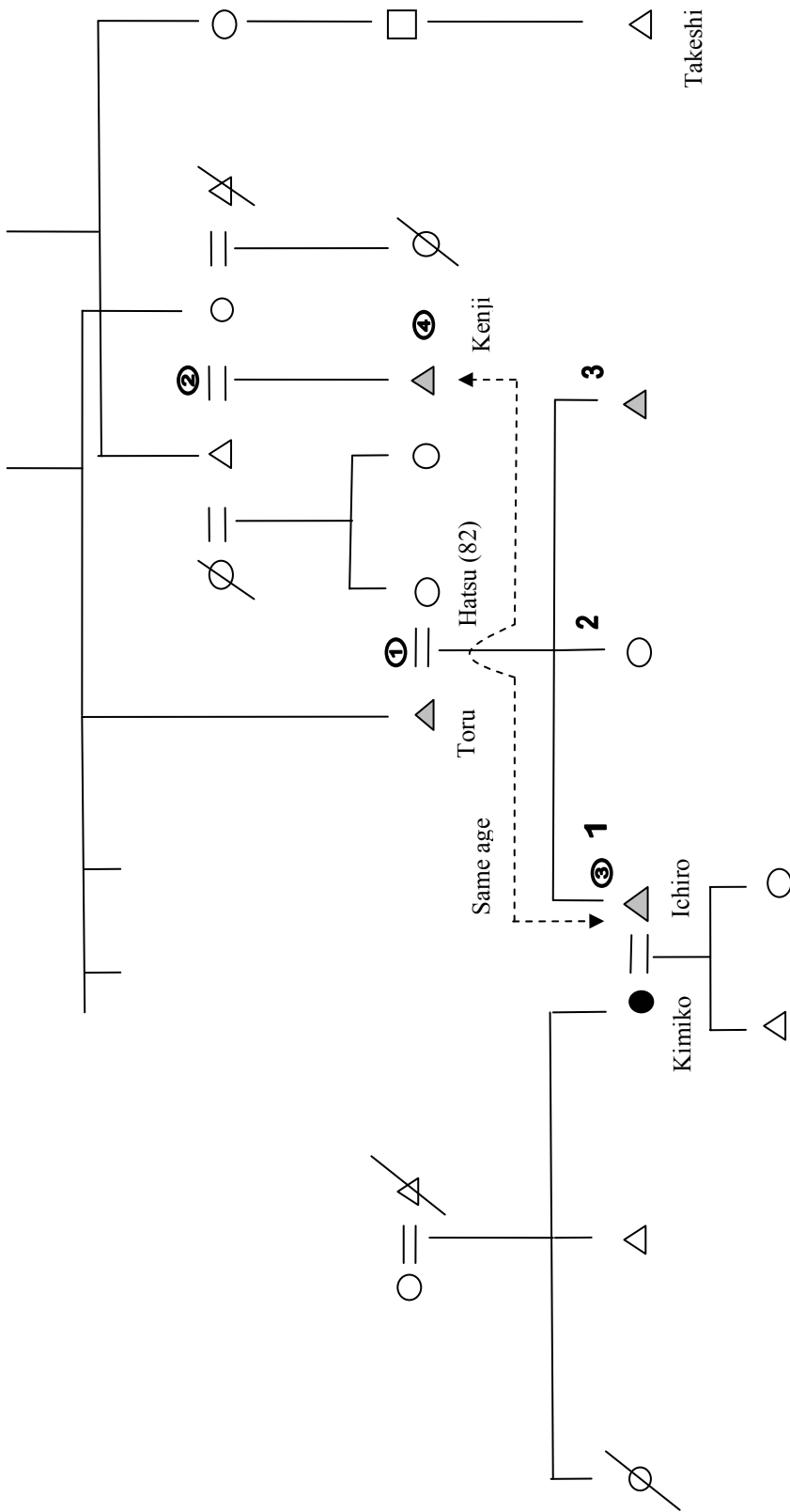

Kimiko Toyota

Kimiko's husband started to abstain from alcohol one and a half years ago. Since then, his violent (drunken) behavior decreased significantly. Kimiko and her two children attend a self-help group where they learn how to cope with their long history as a dysfunctional family. Ichiro, the husband, does not participate in any self-help group. It appears, however, that he is learning from Kimiko and their children who talk about and actually practice what they have learned at the self-help group in the household.

Ichiro's drinking habit before marriage

-----How did you meet your husband?

“We were working at the same company. Both of us were working for “Hansel and Gretel” [a famous long-established confectionary store in the region].

-----Was this a love marriage?

“Yes. We got married when I was 25 years old and Ichiro was 29.”

-----What did you think about his drinking habit in those days?

“Well, since my family doesn't drink, I was not familiar with the custom of drinking. I was absolutely ignorant about the idea that some people change their character 180 degrees when they become drunk.”

-----You just mentioned that your family doesn't drink. Is this because your family members just didn't drink or is it because they are biologically incapable drinkers?

"I think because we are biologically incapable. All of my family members do not like drinking."

-----Could you drink two glasses of wine?

"Two glass? NO WAY! After this much [Kimiko indicated 2 cm with her fingers], I start having a serious headache. Even though I want to drink, I can't."

-----As a person who doesn't drink, how did you view your husband's drinking during that time?

"Well, at that time, he didn't become dead drunk like he did later. So, I didn't think he had a drinking problem."

-----Is your husband *shuran* [a person who gets into a frenzy when drunk]?

"Hmm [pondering]. Well, I think he is."

Ichiro and his work

-----Were there any alcohol related problems such as him being absent from work because of a hangover after you got married and started living together?

“Yes. He was sometimes missing work because of a hangover already at that time.”

-----”At that time” means that he was still in his late twenties, correct?

“Yes. He has an idea he should rather not work if he is not in the perfect condition. This was because he thinks that working in a bad condition rather causes troubles, especially to others. He likes making a distinction between doing and not doing things clearly. And, when he was determined to do things, his motto was to do it ‘beautifully, accurately, and fast.’”

-----Do you still work at the same company?

“I was working there until I retired last year. I once left there for child-rearing after I got married. But when my child entered elementary school, I returned there, first as a part-time worker and later as a full time employee. Ichiro, on the other hand, quit there four or five years after our marriage. He changed jobs frequently: Gingerman [another long-established confectionary store in the region], Seven-Eleven, an insurance company, a game center, a loan company, etc. Sometimes it lasted for only one year but sometimes ten years or so, too. Currently, he is unemployed.”

-----Does this mean that the family income was mostly dependant on your salary?

“No, not really. We had some houses that we rented out. That was the major income.”

-----Hmm, renting houses.... [I hesitantly asked.] Are you rich?

“Oh, no. We are not that rich. But some people say that the reason why Ichiro became like this is because we have these properties.”

-----Is Ichiro’s changing jobs related to his drinking?

“Yes, it is related to his drinking habit.”

Three years after the wedding

-----Tell me about any alcohol related problems you have experienced during the period from your wedding until you started to consistently think that Ichiro is an alcoholic.

“Three years after our wedding, he started to have headaches. Perhaps he was drinking too much every day. So he consulted a psychiatrist and was hospitalized for three months. After the hospitalization, he consulted a different doctor who diagnosed him as ‘character disorder/abnormal character.’ Since I did not accompany him for the consultation, I don’t know anything more than this.”

-----What do you mean by ‘character disorder/abnormal character’?

“Well, I don’t really know, either.”

-----Have you asked your husband what that means?

“No. I just heard that he was diagnosed as such. I didn’t ask anything further. I couldn’t.”

----Is there any incident or situation that makes you think that he has the so-called
“character disorder”?

“Not really. Well...but, there were occasions when he shut himself up for a while—maybe for ten days—when something unpleasant had happened to him. When this happened, he locked his bedroom door and didn’t respond to us at all, even the call for meals.”

-----Was he physically abusive during such occasions?

“No, he wasn’t.”

-----Were you convinced/satisfied with this diagnosis of “character disorder/abnormal character”?

“No. In fact, I am not convinced.”

-----By the way, how was his drinking habit at that time?

“Oh, he was drinking quite frequently, sometimes with his colleagues and sometimes with his relatives. Since he drank more than his body could handle, he vomited, and sometimes couldn't go to work because of the hangover the next day.”

-----Did you think he had a drinking problem at that time?

“No, I didn't particularly think that his drinking habit was problematic.”

Having difficulties communicating with others

-----[I muttered.] I wonder what factor made the doctor diagnose him as “character disorder/abnormal character.” Shutting himself in sounds a bit unusual, but that's not enough to be diagnosed as “character disorder/abnormal character.” You said there is no violence, too. Hmm [I wondered if there was something she was not telling me.] By the way, was there any verbal abuse, for instance you having to listen to his endless grumbling, at that time?

“I am not sure whether or not this may be called grumbling. My husband, in his heart, believes that he is really a capable person. Do you know those commonly held presentations in companies, which are intended to educate the company's workers? [I

nodded]. Well, when such presentations were held and the invited specialists give lectured on management, he later on lectured to me saying that the lecturers were telling lies. He took some management courses when he was in university.”

-----He says “the lecturer is wrong” to you and not to the lecturer himself directly?

“Yes. My husband cannot communicate with others very well. Because of this, I don’t think he has many real friends. His so-called ‘friends’ are often people who grew up with problems, such as family problems.”

-----Is he *sabishigariya* [a person who constantly seeks other people’s care]?

“Yes. But he is a person who can’t say his needs for care by himself. [Kimiko paused]. But that is what I realize these days. In those days, I used to think his bottled-up feelings were due to his fault as someone who can’t properly express what he needs to say.”

Ichiro’s family environment; strict rule of avoiding shame

Not being able to express himself is not just limited to Ichiro in his family. Repressing one’s feelings which often ends up exploding seems to be an old Toyota family custom which has existed at least since Ichiro’s childhood. There is a strict rule in this house: people are supposed to hide shameful events, and to attain this goal, they make every effort to keep up the proper appearance. In this situation, each member’s discontents do not count; there even seems to be a great value attached to the behavior of repressing oneself.

The wife's role within the family

In this situation, people, especially the wives, are expected to work hard to minimize the risks while enduring the difficulties they confront. This seems to be an expected behavior for the wives, something that is taken for granted in this family. It even looks as if the women's role in this household is to support the men in order to set them off to their advantage. The following are some of the episodes that illustrate this point.

(1) Conversation about Ichiro's absence from work because of the hangover

“Suppose Ichiro is not going to work because of a hangover. When this happens, my mother-in-law [Ichiro's mother] urges me to call his workplace saying that he will not be attending work on that day. She asks me probably because she believes it is the wife's duty. Although it is not my real intention, I do what I am told since it is unavoidable. On that day, my mother-in-law keeps up the appearance by removing Ichiro's shoes and coat from the entrance room and pretends that he has gone to work just like usual.”

-----Why do you have to do such things inside the house?

“I think she did this because she thought my father-in-law would get angry and scold Ichiro badly when he noticed that Ichiro was missing work because of a hangover.”

(2) Grandfather's care

“My sisters-in-law and my brother-in-law's wife, Tsugie and Mieko, took elaborate care of the bedridden sick father-in-law [Ichiro's father] for three years. Saying, ‘I don't mind about myself. As long as he is fine, I am happy,’ they took care of him, perhaps more than they took care of themselves at that time. They had a value system different from my own. They sacrificed and sacrificed for my father-in-law even when their bottled-up feelings exploded and they also became ill due to the everyday chores. I often said to myself: ‘why do they make so much effort?’; ‘Are they doing this because they want to be recognized by the family, the understanding that they are making such effort [≈sacrificing] for the whole family?’”

(3) Parmesan cheese and *Sanuki udon* [Sanuki Japanese noodles]

“For Ichiro, spaghetti must always go with parmesan cheese: without parmesan, spaghetti is not considered spaghetti. Grandmother often asked me to go out and buy parmesan when she was planning to cook spaghetti for his lunch. If I couldn't, he asked my children to go and buy it at the store. [Kimiko pauses.] There was also an occasion like this. One day, my brother-in-law came to visit from Tokyo and it was one hour before his departure back to Tokyo. Grandmother asked him, ‘What do you want to eat?’ My brother-in-law replied, ‘I want to eat *Sanuki udon* [Sanuki region's style of *udon*].’ Unfortunately, we didn't have the ingredients at that time. I thought it would be good if we could cook something with ingredients we had in the house. And think about it, it's only 1 hour until his departure! One hour! But contrary to my expectation, my mother-in-law demanded me to go and buy the missing ingredients: ‘Your brother-in-law wants to eat *Sanuki udon*. It would be good if

somebody could go out and buy the ingredients for him.’ So there I was, rushing to the neighboring supermarket to buy *Sanuki udon*. After I came back, with the help of grandmother, we made the dish for him in a hurry. [Kimiko paused.] You see... My mother-in-law is somewhat sly. She doesn’t/can’t say things clearly when she demands things from people. She is also a dependant person. If there is something which is hard for her to ask, she always—I mean really always—expresses this feeling in a very abstract manner.”

(4) Offerings to the ancestors

“Another thing that upsets me about my mother-in-law is that although she demands many things in detail from me, she herself doesn’t do as much as she asks me to do. For example, for the offerings on the Buddhist altar²⁶, she gives me many directions: ‘you are not supposed to offer four legged animals’; ‘It is important to offer fresh food every day’; etc. The worst time is the beginning of a new year. On January first, I am expected to make this; on the second I must make this but not that; on the third I must... This goes on until the 15th of January. Did you know that you are not supposed to serve chicken until the 15th?”

-----Really? I am sorry but I occasionally cook *zouni* [new year’s rice cake soup] with pork since it tastes better.

“I also grew up in a rational family like that. For example, if there is a rule that we are not supposed to place a chicken dish on the Buddhist altar until the 15th, we eat it but just not

put it on the altar till the 15th. But this is not the case in this family. My mother-in-law rigidly followed the rules, such as we should make this on this day and not that on so and so days. Although I worked hard to follow her word, it was a great burden on me since I was also working outside. One day, therefore, I said to my mother-in-law, ‘I can not cook for the Buddhist altar anymore.’ Since then, this became my mother-in-law’s task. Although she was the one who asked me to carefully do many things, she often left an old dish at the altar since she became responsible for it. When I asked, ‘Is it okay to leave the old food like that?’ she answered, ‘Oh, it’s okay. Let’s leave it like that.’ Contrary to how strict she was on me, she was quite easy on herself when she wore the same hat.”

(5) Fixing fish and scallops for husband

-----It sounds like women in this house exhaust their energy quite a bit for their men.

“Talking about exhausting energy, Mieko [Ichiro’s brother’s wife] is the worst one. Her value system is very similar to that of mother-in-law. Always when we serve a fish dish to this family, she carefully removes all the bones from the fish for her husband. Without it being boneless her husband doesn’t eat it.”

-----Wow!

“The more surprising thing was when we served a scallop dish.”

²⁶ Many families in Japan have a small Buddhist altar in their house to worship their

-----Did she remove the adductor muscle from the scallop?

“No, that is something many wives do, too. In addition to removing the adductor muscle, she dissected the scallop, like removing that wiggling orange thing at the side!”

Public behavior [*tatema*] and behavior behind the door [*honne*] (see glossary on page 556)

Although this sister-in-law plays the ideal subordinate woman's role, she has not an ideal woman's character at least from Kimiko's perspective.

“For example, she talks ill about her husband's family in front of me such as saying ‘Oh, I hate visiting my husband's parents' house since these people fight all the time.’ But the moment she sees the grandparents, she completely changes her attitude and says with gratitude: ‘Oh, I am very glad to see you! My husband must be especially happy since he has been waiting for this moment to come’ etc. When I see this drastic change in her attitude and behavior, I think, ‘Hey! You were saying something completely opposite ten minutes ago! How could you change so drastically?’”

-----There seems to be a significant gap between her *tatema* and *honne* behaviors.

“Yes. This behavior is not limited to the behavior of Mieko but also the behavior of almost everyone in the Toyota family. The scary thing is that they do this, even the self-repression,

ancestors.

without noticing it; like a reflex. I wonder if there is a need to keep appearances so much.”

[Kimiko makes a facial expression of annoyance. She pauses and then continues.] My parents-in-law taught Ichiro, ‘Don’t believe what people say; read the meaning behind the words.’ since he was young. Contrary to this, I have a tendency to understand people’s words literally. So, when I married into this house, I was surprised to learn that this kind of house exists.”

Duty as a wife

“It was about seven years ago when Ichiro’s drinking problem became severe. He drank and often became violent. When he was abusive, my mother-in-law always called me at my workplace saying ‘Ichiro is drunk and yelling at us. Please come back, now!’ Sometimes I received these kinds of calls from my sister-in-law saying ‘Mom is suffering since your drunk husband is causing trouble at home! Please go home and take care of my mom!’ There is an idea that I should be responsible for Ichiro’s problems since I am his wife.”

For Kimiko, her career being disturbed by such calls and the disturbance of her sleep because of the endless quarrels between Ichiro and other family members was the most troublesome experience in her married life.

“One day, Ichiro was violent to our daughter. When he caught her wrists which made her unable to move, she called for help to her grandfather (Kimoko’s father-in-law) who was a former policeman: ‘Help! Grandfather help!’ My father-in-law however ignored her; he heard it but didn’t come out from his room. And later I was summoned by him and told to

be more responsible as a wife and a mother. It seems like he thought I was the reason why Ichiro became like that.”

-----Why you?

“He probably thought that the reason for Ichiro’s frenzy was that I was not making enough effort/sacrifices for him which made him unstable.”

Cause of the husband’s worsening drinking habit

-----When did your husband’s drinking problem become severe? Was there any cause for this?

“It was about 9 years ago. My father-in-law died. Ichiro, as the first son, tried to take the initiative for managing his father’s funeral. I think he wanted to be the chief mourner. Contrary to that, the relatives surrounding him were not very supportive of this idea. That pissed him off and increased his alcohol consumption significantly. He started missing work and later he was fired. Ichiro says to me, recalling of those days, ‘People weren’t happy when I said that I wanted to be chief mourner.’”

-----So, who became the chief mourner in the end?

“It was grandmother. [Kimiko pauses.] She was the chief mourner, but she didn’t do much. In this house, some relatives, even though they are distant relatives to us, like to give

suggestions and often cause trouble. For grandfather's funeral, one of the problems revolved around the issue of grandfather's posthumous Buddhist name²⁷, which cost 2.5 million yen [≈US\$ 22,727].”

-----2.5 million yen!

“Yes. Since we thought this was too much, too, our house didn't want to pay for it. We however went through a big discussion for this since the censorious relatives made a big fuss about our tentative decision suggesting to us that ‘we should pay’ or ‘we shouldn't pay’ etc.”

Posthumous Buddhist name

----- Wow! 2.5 million yen! [This house must be rich.] This question is not directly related to alcoholism, but isn't it unreasonable to pay such an amount?

“Of course I am not happy about this. Our house explicitly said to the monk, ‘we don't want to pay that much.’ But our monk is an autocrat; he only cares about money. Frequently he asks for money, 10,000 yen [US\$ 90] for this and even 500,000 yen [US\$ 4,545] for that... Occasionally he reveals how much our neighbors paid and who contributed how much for the religious objects they bought at that temple.”

²⁷ Posthumous Buddhist name: new name given to a person after his/her death.

-----I have heard about terrible Japanese religious workers, too. Although it is considered a sacred job, they can be quite avaricious.

“Oh it’s a horrible story. Our monk travels overseas in the name of a business trip, and brags about his wonderful trip afterwards. He is also particular about beer; he says he only drinks ‘*Asahi super dry* [popular brand beer].’ He is giving a hint for the middle-year and year-end gift giving period. In addition, although the temple is only three minutes walk from our house, we often give him a lift. [Even if the family’s offers, it is proper for the monk to decline the offer in this case.] Finally, several people died one after another these days in our family, and because of this, 1.5 million to 2.5 million were paid for each person’s Buddhist name. We paid altogether 8.5 million [≈US\$ 77,272] yen within the last several years only for these Buddhist names.”

-----8.5 million yen!

Ichiro’s father’s death

The interview returned to the topic of the disputes between relatives, revolving around the grandfather’s funeral, which lead to Ichiro’s excessive drinking.

“For the issue of the posthumous name, grandmother’s cousin’s daughter’s husband Takeshi pressed us to pay. I wondered if he was receiving a margin from that temple.”

-----What did grandmother say as the chief mourner?

“Well, she said, ‘Shall we pay more?’”

-----You mean paying more than 2.5 million yen? Is she a religious person?

“Not really. But she prays every month for her great-grandparents and her husband, some of them died more than 50 years ago.”

-----Doesn't that mean she is religious?”

“No, I don't think so. I think that it is just the force of habit. As a matter of fact, she dabbles in various religions. But since she always quits before her faith deepens, we are the ones who have to clean her mess with the involved religions.”²⁸

Severe drinking problems

-----How did your husband drink at that time?

“He started drinking after he got up and continued drinking until the end of the day. The 2.7 liters [≈0.71 gallon] of *Daigoro* [Cheap *shochu* brand, see glossary on page 557] usually disappeared in three days. He drank like a fish and often became violent like a storming ocean. Since I worked outside during the day, I wasn't as troubled as other family members

²⁸ Since this grandmother has the habit of adhering to appearances, it is possible that grandmother's words “Shall we pay more?” came out of her intension to avoid the bad

who remained home during the day-time. It seems like they struggled quite a bit with Ichiro who violently yelled and yelled.”

-----What did he yell about?

“He was often unhappy with grandmother.”

-----Was there any violence?

“In this situation, he often grabbed at the opponent’s wrists, like in aikido, and made the person unmovable. Besides this, he seldom used violence.” [Note: Kimiko later described her experience of calling the police since Ichiro’s violence was almost lethal.]

----Has he ever struck you?

“No, not really.” [This may not be the truth, as suggested by the previous note.]

----Has he ever pushed you?

“Yes, especially when I tried to tear myself away from him when he grabbed my wrists.”

-----Did he pound the table with his fist in order to win his point?

reputation attached to the family (shame): “that family is poor (the family lacked the money

“Yes, that happened frequently.”

-----Has he ever thrown things at you?

“He seldom threw things at me, but he occasionally threw everything in the room out of the window.”

-----Hmm. Does this happen suddenly when people are not around? Or is it something that happens when there are people surrounding him?

“[He does it] *always* when someone is around. In fact, he announces it before he goes into action: ‘I am going to do it [throw it] now!’ There was an incident when he declared he would put and then did put the house’s *tatami* floor on fire, too.”

-----When this happens, who cleans up the mess afterwards?

“Usually the family members in the house: me, my son, my mother-in-law, etc.”

-----Does that include your husband?

“No way! He will never ever do such a thing!”

to pay)” or “that family is stingy (that family doesn’t want to pay)”.

Continuing the relation--the financial reason

-----Did he verbally abuse you?

“Yes.”

-----What were the words that hurt you the most?

“It was ‘You, get out from this house!’”

-----Why didn’t you leave the house, then?

“I have thought about leaving the house, too. But I couldn’t. The reason is the financial problem.”

-----But you were working full-time. On the other hand, he was an unstable worker, changing his job one after another.

“Yes. But our house, which originally came from my husband’s family, had income from the rents.”

-----I see.

The problem of this family's property is something more significant than I thought. Understanding this part, which I did not pursue [too sensitive of an issue!], is perhaps crucial to understand this family's problem.

For improving the current alcohol related problems of the society

-----Did you have any problem that involved the police?

“Yes. One day, our quarrel developed into an almost lethal fight so we called the police. But, you see, the police are very detached people; they treat our problem as a third person's business. Our family knew how unreliable policemen are since my father-in-law was also a former policeman. In spite of this, however, we called the police. After the call, several police cars with quite a few policemen arrived. The moment they reached our house, however, my husband became very quiet and gentle. The policemen who saw that situation thought that the problem was solved, and thus, thought they should leave the place. We opposed their reaction but their point was: ‘We cannot arrest a person who is non-violent/obedient/quiet.’ In the middle of the night, therefore, I called our doctor, explained him about our situation, and asked him to convince the police to arrest my husband. So, the doctor talked to the police for a while. But, after all, the policemen left our house without taking my husband with them. [Kimiko paused.] You see, even though his rage calmed down because they came, it doesn't mean that our problem was solved. There was the possibility that the calmness was only temporal and he would fly into a worse rage later. This made us uneasy, but the police didn't understand this possibility.”

----- What did you want the police to do for you at that time, then?

“I wanted them to take him with them.”

-----Take him and do what?

“I wanted them to make him realize that what he did was a crime. I wanted them to carefully educate my husband about what kind of sins he had committed. For example, it would be great if he had to go through a compulsory counseling service. Japan is very poor in these kinds of services.”

--- Have you desired such services from places other than the police, such as from the health center?

“I have visited the health center to consult about my problem. I told them that I have been troubled by my husband’s drinking problem and am currently going to a self-help group. When I said so, the officer there said, ‘Oh, then you are more familiar about the available service than we are.’ and gave us some pamphlets and that was the end.

-----Hmm. It seems like the helpfulness of the officer at the health center varies. I know a staff member who was kind enough to visit the house of a DV victim and helped her out.

“Is that right? Well, then, maybe I was unlucky.”

Family background

Kimiko believes that the family norm with its big gap between *tatema* and *honne* is related to Ichiro's drinking. In addition, she believes that his complicated family composition is also a cause of his drinking.

In order to understand this, knowing some of the complex relationships within the family is necessary. There is a man called Kenji who affected Ichiro's life significantly. They spent much time together throughout their lives: periods of compulsory education, high school, university, and Ichiro's first company. Kenji also made Ichiro think of himself as unimportant in the family even though he was the first-born son.

Keinji is younger than Ichiro [in fact they were born in the same year], but is Ichiro's uncle [Ichiro's grandfather's son] as well as his cousin [father's older sister's son] [See kinship chart on p-220]. The story of this convoluted family tree goes back two generations. First, Ichiro's mother [Hatsu] married Ichiro's father [Toru]. At that time, Hatsu's father lost his wife and was constantly having affairs. Therefore, after some troublesome incidents, Hatsu and Toru decided to do matchmaking between Hatsu's father and Toru's older sister who had also lost her husband. Kenji was born out of this marriage between Hatsu's father and Toru's older sister.

“[Kimiko said:] This is something that I was told after I got married. Perhaps they [Ichiro and/or Toyota family] thought I would decline his proposal if I knew about this before the wedding.”

Kenji and lonely husband

“It seems like my mother-in-law always gave priority to Kenji. For example, for Kenji and Ichiro’s school’s parent’s visiting day, she always went to Kenji’s class first and Ichiro’s later which made Ichiro lonely. She should have switched which one to visit first every time... But such a thing never happened; she visited Kenji’s class first all the time. When my husband blames her for that, she gives a farfetched reason for it. She is extremely good at that: ‘Well, your teacher said coming later is better because they can afford more time for the conversation about you.’ Well anyhow, Ichiro was not fond of grandmother giving Kenji priority over him.”

According to Kimiko, Kenji calls this grandmother “mother.”

-----Why does your mother-in-law give so much attention to Kenji, even more than her real son Ichiro?

“I think it was her father’s wish.”

The two were often compared, which caused tension in their relationship. Kenji was a distinguished child who received many awards in elementary school. Contrary to this, Ichiro was a child who was wholly at odds with such things. Under these circumstances, Ichiro felt very small at school. Throughout those days, he had a strong inferiority complex until one of his teachers said to him: ‘You are really a capable child.’ Ichiro recalls this incident even now, saying, ‘If the teacher didn’t encourage me by saying this, I would be

dead by now.’ Time passed and by the time they became junior high school students, the relationship reversed: the time of Kenji who had long been the superior changed and now Ichiro was the better student. Unfortunately, according to Ichiro, his family members were not happy about him being superior.

The two grew up in these complicated family circumstances, carrying difficult feelings, including their turbulent adolescence. Both failed the high school entrance exam and therefore went through the *ronin* period [people who have failed the entrance exam and are waiting for another chance next year] together. Ichiro passed the exam the next year while Kenji failed again. The next year, he entered a school, but since he was unsatisfied with the school, he changed schools three times afterwards. Fortunately, Kenji as well as Ichiro graduated from high school. After their graduation, they entered the same university and were employed by Hansel and Gretel, the long-established confectionary company in the region through their family connection.

The relationship between the two was quite serious at that time of their lives as Hansel-and-Gretel employees. The family made an arrangement with the company to separate them: Ichiro, as the first son, was to remain at that place while Kenji was to be appointed somewhere else. However, due to the company’s mistake, it was Kenji who remained and Ichiro who was appointed to a store in the countryside, in no-man’s-land. This happened when Ichiro was 24 years old. Ichiro had to move into an unexciting very small city, alone. This *tanshinfunin* [business bachelor] period increased his alcohol consumption. Five years later, Ichiro was appointed to a store in his hometown and was able to live with his parents again. However, since there were young relatives lodging in his

house as university students, contrary to the expectation he held during his *tanshinfunin* time, he felt excluded, feeling that there was no room for him in the family.

Drinking occasions when relatives gather

----- [I was looking at husband's lineage in the kinship chart] Who are the drinkers here?

“Everyone.”

-----Men and women?

“Yes almost all men and women.”

-----Could you tell me the people whose spouses are having troubles because of their partner's drinking problems?

“This man, this man, and this woman's husband, and this woman...”

-----That's quite a few. Do these relatives cause trouble when they visit your house?

“Ooooh yes, ooooh yes. [Kimiko made a troubled face.] When there is a family gathering, it's awful, really awful.”

-----Do quarrels happen often?

“Ooooh yes. All the time. This woman [Kimiko pointed at a certain woman in the kinship chart], in the past, used to visit our place every weekend and ended up crying all the time.”

-----Between whom and whom do quarrels occur?

“Well, my husband does it with this man and that man but the quarrels involving him are relatively minor compared to those of some other people. There are combinations between this man and that man [different person], and this one [different person] and that one [different person].

-----It seems like the participants are mostly men. [Kimiko nodded.]

Ichiro's mother

“There is a pattern. The quarrels occur and some of them last until the morning. And when this happens and the situation becomes unendurable, my mother-in-law comes up and rescues the situation by saying, ‘*Watashi ni menjite* [for my sake], please stop fighting.’”²⁹

-----Does the prolonged quarrel stop if she says that? -- ‘Stop fighting for the sake of me.’

²⁹ *Watashi ni menjite* means ‘for my sake’ or ‘because of me.’ It conveys a great desire without giving any reasons. Usually the person making the request commands the respect of the other people involved. If a person uses this expression frequently, however, it loses its magic, as is the case for this grandmother.

“No, it doesn’t. But this is the pattern all the time, really all the time. Although people in this family are very strict about following the rules such as ‘not to fight’ or ‘not to grumble,’ once alcohol enters their bodies or if it becomes impossible for them to endure the situation and their bottled-up feelings explode, the rules are ignored completely. [Kimiko pauses.] When the quarrel lasts until late at night, you become really tired. I honestly wish they would sleep in on the next day since usually it is a weekend holiday anyway. But, you see, the ringleader of the quarrel always gets up early and eats breakfast early in the morning. [Kimiko makes a troubled face.] When this happens, my mother-in-law always curries favor with that person by serving tea and breakfast or asking ‘What do you want to drink/eat this morning?’ And women who cannot do this, like me, are considered unqualified as a wife, in other words a bad person, according to her standards. You see, they are the ones who quarreled and made us sleep deprived, why do I have to sacrifice even further? There is one more thing I want to say. Since they are now both sober, why don’t they discuss about last night’s issue now? I think if they are both calm, it is possible that they find a good solution to the problem which wasn’t solved the previous night. Well, in fact, it is considered very preposterous; because fighting is an absolutely bad thing in this house. Because of this, putting the dirty things back on the table is something we shouldn’t do. No matter what, people in this house never ever talk about the previous day’s quarrels later, when they are sober. Not even a word.”

-----By the way, what is usually the cause of the quarrels?

“Well.... [Kimiko appeared to be thinking hard for about a minute..] Sorry, I can’t remember. I do remember that they fought, but I can’t remember the reason of the quarrels even though I am trying this much. It’s so weird.”

Self-help group

-----Do you go to a self-help group?

“Yes, I do.”

-----What made you go there?

“My husband’s drinking problem became severe. His liver disorder worsened and he started having abdominal dropsy, too. His belly became so big that he couldn’t get into the car. His weight increased from 60 to 89 kg [\approx 132 to 196 pounds]! It was unbelievable. He also had auditory hallucination. He was saying things that didn’t make sense: ‘I hear Kenji’s voice.’ At that time, I thought he was really going to die. Because of that he was hospitalized. This gave him the opportunity to abstain and me to participate in the self-help group. Since then, although he slipped [drunk again] twice, he has continued his abstinence until today. Our life is quite peaceful now compared to those days.”

The hospital that Ichiro entered was a big hospital, but it was not a hospital that specialized in alcohol treatment.

-----Does Ichiro also go to the self-help group?

“No. It’s only me and my two children who go to the self-help group. The three of us are also receiving counseling services, too.”

-----Is it okay that your husband is not going to the self-help group?

“Well, he never wants to go to such a place, but he is a lot better now than he used to be. These days he shows some interest in what we are doing and learning at the self-help group. These days, my children and I try to practice at home what we have learned at the self-help group. For example, people in our family use words which hurt others, which is bad. So we try not to do this by being careful with our choice of words. We also try not to ask things vaguely; one’s request must be expressed clearly. By doing that, I think my husband is grasping the picture of the self-help group, what kind of things we do and learn.”

-----Doesn’t your mother-in-law participate in the self-help group?

“Well, by hearing the stories from us, she showed interest and said ‘I want to go there, too.’ voluntarily. We have taken her there a few times, but it didn’t last. It seems like she is not used to her problems being pointed out by others and thus feels uncomfortable, which makes her want to return home right away.”

-----How many points out of 100 do you give to your current married life?

“I will give it about 70 points, I think.”

-----How about in the past?

“Zero.”

It seems the problem is not with Kimiko herself but with the family members surrounding her. Because of this, it is them more than her who really need the help which can be obtained from self-help groups. During the interview, I also asked about her family background which might be related to her being an alcoholic's wife. When I asked her if she has a co-dependence problem and, if so, what would be the major cause of it, she answered that *if* she has co-dependence problem, the major cause would be the experience of losing her father when she was still young. However, she thinks this idea is a farfetched interpretation of herself and therefore unconvincing. Instead, she thinks the biggest problem for her continuing the torturous married life with Ichiro was the cultural norm related to gender, the idea that the woman should support her husband and stay married with their first partner.

Case 11. When he died, all the bad memories disappeared completely. Right now, I only remember good things. It is rather hard for me to remember bad things about him.

Name				Age		Occupation								
Sakura Kobayashi				54		Owner and manager of a cake shop								
Family						Husband's Occupation								
Nuclear		Extended		# of members		6		Owner and manager of a cake shop						
Family members														
Taro		Husband		57		Deceased (8 months ago)								
Sakura		Wife		54										
Kazue		First daughter												
Tsugie		Second daughter												
Kikuzou		Taro's father				Deceased (2-3 years ago)								
Sachiko		Taro's mother				Deceased (several month ago)								
Total Interview Time				Wife Attending Self-help Group?				Husband Attended Self-help Group?						
2 hours				Yes No				Yes No						
Wife's KAST concerning her husband's alcohol related behavior (See Appendix 1 on Page 546)														
1	2	3	4	5	6	7	8	9	10	11	12	13	14	Total
3.7	3.2	2.3	2.2	2.1	1.7	1.5	1.2	0.8	0.7	0.7	0.6	0.5	0.5	11.2
-1.1	-1.1	-0.8	-0.7	-0.7	-0.4	-0.5	-0.2	-0.2	0	-0.1	-0.1	0	0	
?	?	?	?	?	?	?	?	?	-0.2	?	?	?	?	
Analysis (See Analysis on Page 489)														
A1	A2	A3	A4	A5	A6	A7	B1	B2	B3	B4	B5	B6		G1
C1	C2	C3	C4	C5	C6	C7	D1	D2	D3	D4	D5	D6	D7	D8
E1	E2	E3	E4				F1		H1	H2	H3	H4	H5	H6
Types of Problems (See Analysis on Page 489)														
Verbal Abuse		Physical Abuse		Financial		Psychological		Shirinugui		Child-Related				
Note														

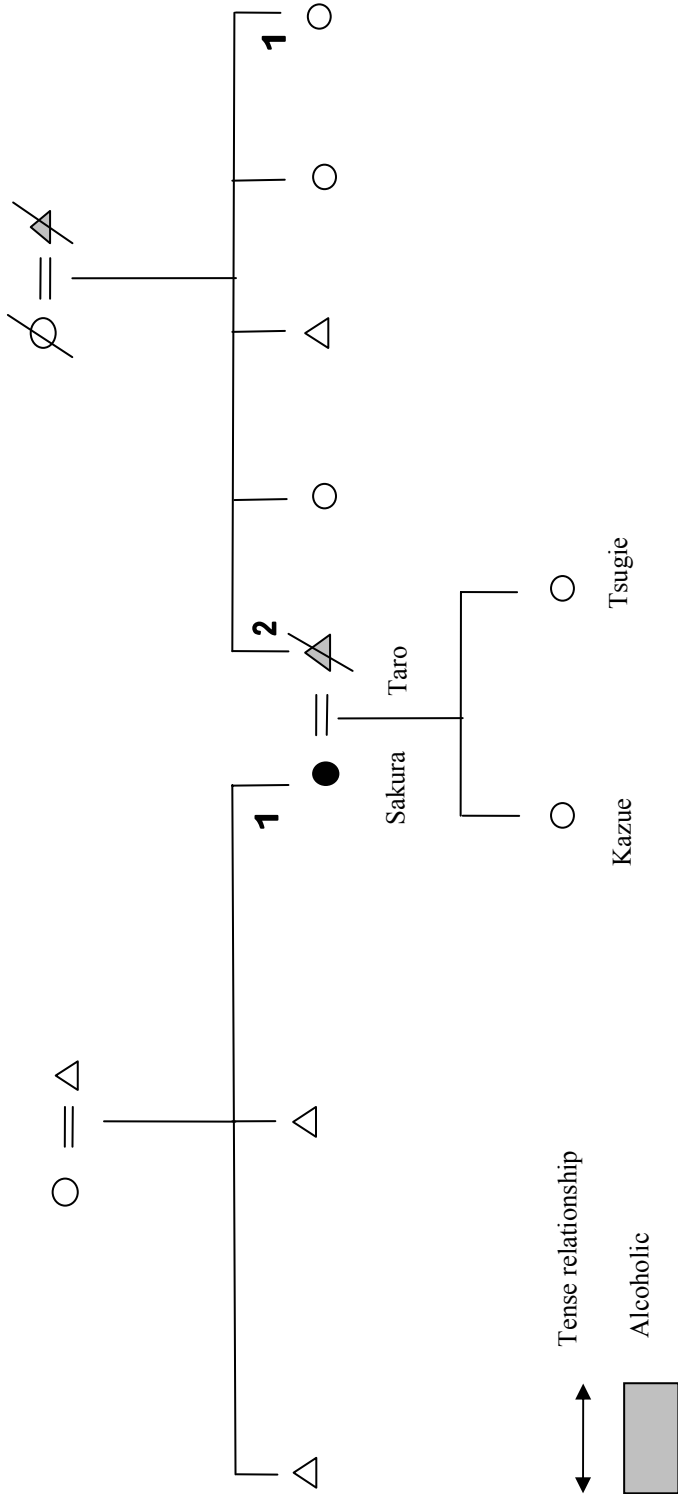

Sakura Kobayashi

Sakura is 54 years old. She is very energetic when she is dealing with customers at her shop [She is the owner and the manager of a self-owned cake shop]. My impression of Sakura was that she is a nice and a cheerful woman. Sakura lost her husband just 8 months ago. I was painfully aware that interviewing Sakura about her husband's alcohol problems, which were related to his death, might be difficult for her. Nonetheless, I still felt it necessary to interview her. I wanted to know the heart of a woman who lost her husband because of alcohol dependence syndrome. What does a wife who lost her alcoholic husband feel? Is she now in comfort? Or does she feel anger? If so, against whom? Her husband, or herself? It could be against the medical institution which failed to cure his disease... There may also be a feeling which can be expressed neither as relief nor anger. I braced myself more than usual and went to her cake shop where the interview took place. Since Sakura was very busy, it was most convenient for her that I came to her workplace. When I entered the shop, the place was filled with the delicious aroma of the beautiful cakes.

How Sakura met Taro

-----How did you meet your husband and get married?

“Before marrying, I used to work at a mall. My father-in-law was originally working at a city office, but when he retired, he started to work at a confectionary store in the mall where I was working. I met Taro through him, my father-in-law.”

They had an *omiai* [meeting where prospective marriage partners meet with each other through a go-between], and got married when Sakura was 24 years old.

-----Were you informed about your husband's drinking habit at that time?

"I was told that 'He drinks to some extent,' but I didn't know that it was that much. But at that time, although I thought he drank a lot, I didn't think it was a problem."

The time when Taro's alcohol consumption increased

-----When did you start thinking that your husband's way of drinking is not normal?

"I think it was when the children were in junior high school and in high school. He started drinking to get drunk."

-----Was he drinking 'pleasantly' or 'negatively' such as becoming depressive or angry?

"He wasn't a pleasant drinker, for sure. Once in a while I saw him laugh but, most of the time, he wasn't pleasant. He did not become cheerful and talkative when drunk."

-----When he became drunk, did he become mad or resort to violence?

"No. There was no physical violence. He did become tedious, though. [His tediousness will be described further later.]"

-----What was he drinking and about how much?

“He was drinking *sake*. I don’t remember in detail, but I think he emptied 1 *sho* [\approx 0.8 liter \approx 0.48 U.S. gallon] *sake* bottle in 2-3 days. That means 3 *gou* [\approx 0.54 liter \approx 0.14 gallon] per day...or something like that. It seemed like there was no distinction between alcohol and water for him.”

-----When he drank, did he eat, too? In other words, did he drink with a meal? More precisely, how much food did he eat? Just a little bit of relish? Did the meal include staples, like rice?

“He was drinking mostly during the supper time. He was drinking with the relish as his main dish, and that was it. He wasn’t eating staples [rice] at all. This was his dinner pattern for a long time, even before his drinking habit worsened.”

-----Where did he drink most of the time, at home or at bars?

“He mostly drank alone at home. He often drank after work. He sometimes drank with his father, too. By the way, my father-in-law was a drinker, too. [Sakura paused.] My husband occasionally went outdoors and drank, too. His hobby was fishing... When fishing, he liked drinking with his fishing friends at the spot where they were fishing. I have joined him several times, too... [Sakura looked like she is recalling those days.] He had the habit of

bringing back his garbage.... So, [Sakura laughed.] even though I had been telling him not to drink, I noticed he wasn't following my words because I often found empty alcohol bottles in the garbage bag he brought home. [Sakura laughed and tears started rolling her face.]”

-----Had he ever missed work because of a hangover, or negatively influenced his work because of his alcohol related problem?

“No. When it comes to work, he was a person who did what he had to do no matter what happens. Well...but, at the end, he was going to work only in the morning and staying at home the rest of the day since he was too sick to work. He was sick, you know... But, he was drinking beer at home nonetheless. It seems like he did this since he had nothing to do when he was at home. He was drinking beer since I always reminded him: ‘Don’t drink *sake* while I am away!’ [The word *sake* in Japanese means a certain Japanese liquor, but it also means ‘alcoholic beverages in general’.] [Sakura laughed.]”

-----What reason did you give to the employees for him not coming to work?

“Well...just like normal. I just told them something like, ‘My husband is not in today, or this afternoon since he is not feeling well.’”

-----Have you ever found him sleeping on the floor or in the corner of the room because he was too drunk to go to his bed? Also, has he ever had a toilet accident while drunk?

“There were occasions when he was sleeping in a hallway drunk in the middle of the night. Since he was incapable of going to his bed alone, I helped him go to the bed and change into pajamas. In terms of toilet accident...yes, it happened near the toilet once.”

Reaction of Sakura against her husband’s drinking

-----Sometimes, a wife of an excessive drinker develops certain behaviors such as hiding alcohol bottles or adding water to the husband’s bottles based on her intention to prevent him from drinking too much alcohol. Have you done anything like that?

“I did hide alcohol drinks, like putting them in my wardrobe. There was one time when he found it and asked me, ‘What is this (sake bottle) doing here?’ I didn’t add water to his sake bottle, though. My father-in-law told me that he used to add water to his *sake* in order to reduce his drinking, but it caused him drunken sickness or, how could I say, bad drunkenness. Because of this, he ingrained into me not to add water to *sake*. So, I have never thinned sake with water, not even once.”

-----While he was drinking, were you careful or restraining yourself in order not to make your husband upset?

“I did try not to say unnecessary things, especially things that could negatively affect his feelings. But, even if I tried not to say too much, the discontent that he drinks too much was something I carried in my mind all the time. I knew I shouldn’t, but I couldn’t help it. As I

said before, he becomes tedious when he was drunk. But that's not because he complained about certain problems. It is usually because I complained to him, 'Not again! Enough of this drinking [Sakura said this in an upset tone]!' or 'Stop drinking! [Sakura said this in an annoyed tone.]' to which he replied things like 'Why can't I drink! What's so bad about it?!' We both became defiant and we went on like this forever."

Sakura's feelings

-----Could you please illustrate your feelings at that time with an anecdote?

"With an anecdote.... [Sakura looked as she was thinking.] I don't think there is any... I don't remember anything."

When I decided to go on to the next question with the idea that there is no need to force her to recall her bad experience [if there were any bad ones] about her recently deceased husband, she replied.

"It's strange... I am sure there were many disagreeable things. But, when he died, all the bad memories disappeared completely. Right now, I only remember good things. It is rather hard for me to remember bad things about him."

Reason for drinking: expanding business

Sakura thinks Taro's excessive drinking habit was strongly related to his busy job.

“The time my husband’s drinking consumption increased significantly coincides with the time when our business became very busy. We expanded our business by opening new shops until we reached 5 shops. My husband was working hard from very early in the morning until 7 o’clock at night everyday throughout. We employ relatives. Because of this, we have problems peculiar to family-owned-businesses. My husband dealt with all these, and I am sure it wasn’t easy. Taro was also managing all the legal and financial matters, too. During the Japanese economic depression time, our sales decreased by 50%. It was hard, but he managed everything all right. He was tense all the time. And that’s the reason why I think he escaped to the world of alcohol.”

Now, as the owner and the manager of the cake shop since the death of her husband, Sakura feels for her busy husband of that time as follows:

“These days, when I come back from work, I occasionally pour a little bit of wine in a glass and drink. When I do this, all my strain goes away and I feel *huuuuuuh*... [Sakura made a big sigh]. And then I feel for my husband: ‘I understand now, Taro. I guess you were drinking with such a feeling, weren’t you.’ [Sakura smiled with tears.]”

-----Do you think you were relying or depending too much on your husband?

“Yes. When I think about those days now, I think I was doing *onnbu ni dakko* [baby being carried in the front and the back at the same time, ≈depending heavily on someone]. I think I was *amae*-ing [easy on myself, see glossary on page 554]. Right now, due to the Japanese

economical problems and so forth, we have only one shop remaining which is this one. Taro used to open the shop at 8 o'clock, but I open it at 9 o'clock. It's amazing how much one doesn't understand about other people's pains until one starts having those problems oneself. Right now, I often realize how much I didn't understand about Taro. I really didn't know anything about him. At that time, I was thinking 'Boy he makes a lot of effort...' or 'Gosh, that looks like a tough job...' But I didn't truly understand from the heart. Maybe he was thinking 'It's no use to grumble to the family members...' at that time."

Separation between work life and private life

"My husband disliked having work related conversations at home. Work life is work life. Private life is private life. Those two must be separated. That was his motto. When he came back home, he tried not to think about work-related matters if at all possible. There was a rule that work related conversation was prohibited in our house."

This was however just a principle; he couldn't completely forget about work when he was at home. According to Sakura, he occasionally drank to forget the troubles of his work day. Sakura also told me another story about his strong desire to separate the private life from the work life.

"Our house was far away from the shops. I thought it would be convenient if the shop was part of our house. If so, I could do the laundry during the spare time and so forth. So, one day, I suggested this to him, but his reply was, 'If we do that, I will become neurotic!' It seemed like an outrageous idea to him."

Hard working husband

-----It sounds like your husband was a very hard working man.

“Yes, he was a very hard working man.”

-----Could you tell me about his character briefly?

“He was a very considerate person. For example, since we operate cake shops, we receive various requests from customers: ‘We want the cake to be delivered to this place by this time’ or ‘we want the decoration to be like this and like that.’ Some are very detailed and tiresome. But Taro always tried his best to satisfy the customers. He was very careful every day to achieve the requested delivery times. For detailed requests, he tried his best to satisfy the customers. At any event, it was a priority to please the customers. He never showed his anger or negative feelings at work at all. Perhaps this was the major cause of his stress. [Sakura paused.] Thanks to his instruction, I am somehow managing the shop okay. He always told me ‘to be punctual,’ ‘to ask the customers about their requests beforehand in detail’ and ‘to make the customer happy.’ He told me such things and here I am working as he told me every day, right now. When I married into this house, I didn’t know my way around in this business at all, but now with all his instruction, I am working on my own, naturally, without any problem. It’s amazing...”

Taro had a thorough character [perfectionist], too.

“He was a skilled man. He was also very good with his fingers. He liked drawing pictures, some of them made it to the *Nitten* exhibition [the most competitive annual art exhibition in Japan]. Also, when he decided to do something, he did it until he attained the top grade qualification in that field. I quit before reaching that kind of level, but he did things thoroughly when he made up his mind to do something.”

When Sakura told me this, I looked at the certificates of merit presented to Taro which were displayed on the wall at the shop.

Reasons for husband’s drinking--part 2

-----Were there any other reasons for his drinking besides the work related stress?

“Hmm. [Sakura pondered.]”

-----By the way, did you have any mother-in-law problem?

“It will be a lie if I say I didn’t. My mother-in-law only praised her own children even though I was making a lot of effort. I was discontent about that which led to grumbling about my mother-in-law to my husband. I complained to him like ‘Why is she always on her children’s side and not mine?’ I think it put him in a difficult position between me and his mother.”

-----What was the position of your husband at that time: on your side, on his mother's side, or in a neutral position?

“He wasn't on either side most of the time. If my mother-in-law said irrelevant things, he scolded her, and when I said something wrong, he said to me ‘Get out from the house!’ too.”

-----So can I say that he took a relatively fair position on this issue?

“Yes, I think so. [Sakura paused.] By the way, now that I am also old like my mother-in-law at that time, I understand her feeling of those days very well. Just like my mother-in-law, I feel that my children are the dearest right now. As I said before, you don't really understand until you actually experience it.”

From this, I concluded that the bride and mother-in-law problem is not directly related to Taro's excessive drinking.

Emotional support from relatives and friends

-----When your husband was drinking a lot and you felt it was a problem, did you have anyone to talk to about the problem?

“I consulted my husband’s sisters and a person called Mrs. Tanaka. I said to them things like ‘My husband just doesn’t stop drinking’ or ‘How can I make him stop drinking? What shall I do?’”

-----When you consulted these people, did you feel you were properly understood?

“They listened to me and sympathized saying ‘Yeah, that’s the way drinkers are.’ but I don’t think they really understood the pain I was experiencing.”

Self-help group

-----Have you ever approached any kind of public services such as the public health care center or the telephone consultation service to solve your husband’s drinking problem?

“About 2-3 year years ago, Mrs. Tanaka recommended that we go to a self-help group. I was quite skeptical whether this is really going to work for us. My husband was not a social person... Therefore, we ended up not going even once after all.”

Husband’s death

Our conversation shifted to the topic of Taro’s death.

“Taro died peacefully at the hospital. He had kidney dialysis in addition to the alcohol problem. The last hospitalization was because of pneumonia which developed from a flu. He felt intense ache and therefore was sent to the hospital by ambulance. Around that time,

he had been repeatedly hospitalized... Two months before the last hospitalization, he was hospitalized for two months, too. [Sakura paused.] As for the last hospitalization, the pain was so severe that the doctor gave him morphine. One time, the morphine amount was too much so that he stopped winking... They stopped the morphine injection immediately and he recovered his consciousness... Anyway, around that time, the doctor warned me that he may pass away soon. I told the doctor, 'Whatever you say, I understand. But please, just please soften his pain, even a little bit.' Since Taro was in a critical state, I informed his relatives such as his siblings who live far away, and many of them visited the hospital to come see him once before his death. [Sakura paused.] On that day [the day he died].... he had a medical check up scheduled at 2 o'clock in the afternoon. In order to manage everything on time, I was busy on that day from early in the morning. Before that day.... he was crying because of the pain....saying '*Aaaa! Aaaa!*' more than usual.... In the morning, my daughter was looking after him. When she asked him, 'Dad, what do you want to eat?' he replied, 'Whatever you make is fine...' My daughter is a pretty good cook... Some time after that conversation, he died peacefully at 12:43. It was after he finished his lunch but was before the check up..."

Two people' deaths

At that time, Sakura was taking care of 2 sick people who were in a critical state. Sakura's mother-in-law was also hospitalized with cancer. She was already hospitalized before Taro's last hospitalization.

“I was told by the doctor that my mother-in-law may die earlier than my husband. Since my husband was a considerate son, he was more worried about his mother’s condition than his own. But he passed away earlier than his mother... And one month after his death, his mother died, too. Everything happened all at once. My mother-in-law’s death was before the 49th day after my husband’s death [In Buddhism, the 49 days following death are the period when the dead person’s life is judged and the reincarnation is determined. It is believed that during this period, the dead’s soul is wandering in this world.] Although possibly my mother-in-law wanted to die at home, she died at the hospital.”

-----You lost two important people in your life within these 8 months. It must have been an extremely hard time for you, taking care of these hospitalized people and the funerals...

“Oh yeah... It was really tough... [Sakura paused.] But I did my best. I have no regret. Yes, of course I come up with small things such as ‘I should have done this or that’ or ‘If I had done this in this way instead of that way, it would have been better...’ But that’s okay. I truly made a sincere effort so I have no regret. Since my mother-in-law was an old woman, someone suggested that we should do a small funeral with only the relatives. But we had a funeral as big as for my husband.... Truly, I have no regret.”

Tough time

-----I can’t believe you are working apparently so normally despite the fact that you lost two important people in the last 8 months. Are you really okay?

“I really didn’t want to do anything for the last several months. But I went to work during those days because I had to. During that time while I was working, my mind got mixed-up and I felt very hot suddenly. I experienced that several times. I also occasionally felt my feet were not on the ground; I felt like I was floating. Until very recently, I didn’t want to cook either. After I came back from work, I just couldn’t cook. When this happened, my children asked me, ‘Mom, are you going to cook today? If so, when?’”

-----Did/do you suffer from depression?

“I tried not to become depressed by reading books or by talking with friends. In the past before Taro’s hospitalization, I used to hold a baking class. The class has been canceled since my husband illness became severe. But these days, since my friends [who are also her students] asked me when I am going to start the class again, I started to hold the class again. [Sakura paused.] In addition, since we have a debt at the bank, I had to be strong. I have been saying to myself, ‘Sakura, you have to be strong.’ and ‘Sakura, there is no time for you to cry.’”

Talking to the Buddhist altar

Since her husband’s death, Sakura frequently talks to the Buddhist altar.

“At the beginning, I used to complain to my husband while facing the altar. But it is more common these days to talk about the difficulties he was experiencing when he was alive. Now that I have to manage everything responsibly, I feel like I understand his situation at

least a little bit. I say things like ‘When you were alive, we were too busy so that we didn’t have much time doing work together.’ or ‘I didn’t say many kind words to you.’ [to the altar].”

-----Do you think he is saying ‘You finally understand!’ to you from heaven?

“Well....perhaps he is. [Sakura stared into the distance.]”

Doctor’s responsibility

-----Alcohol dependence syndrome is a mortal disease. But it is possible to recover from it. Unfortunately, in your husband’s case, he died. Right now, if you have any regret or discontent regarding the services you wanted to receive from medical institutions, public health-care centers, or society, please let me know so that these things may be improved.

“I wanted to know what was really happening to his body. Take, for example, liver disorder. I wish I knew what was happening to his liver and what that means. I wanted the doctors to tell me whether it came from his excessive drinking or from stress. I wanted them to tell me, not just him, but also his wife. The doctor can understand immediately what is going on by looking at the numerical data and the pictures of the patients’ internal organs. We as non-professionals, however, can’t. We don’t know what is going on, at all. I wish they told me in a way I can understand. I wanted the professionals to tell me what was wrong in what way and therefore what needed to be done. I wanted to know in a way I could understand. I don’t want them to tell him ambiguously, something like ‘You should reduce your

drinking'; I wanted them to tell me clearly about his problem, to me. If I had known he would die if he kept drinking like this, I would have been more careful to make him stop drinking, too. As the proverb '*sake* is the best of all medicine' says, I may have reduced his drinking to a harmless amount. I would have said it differently when I complained about his drinking to him, really. It's so true, because it's a big problem for me if I lose him, too."

-----Right... If you understood the problem well, you would have probably thought about the problem you were about to confront as well, that is the situation of rest of the family who will be left behind with the remaining shops and the debt. In that case, you might have thought about how to deal with his drinking problem more seriously and constructively, too.

"Yes. I used to ask my parents-in-law, 'Please tell my husband not to drink from your mouth.' but they believed that alcohol could not kill people and responded 'Well, he likes drinking. Let him drink as much as he wants.' If I really understood the danger of alcohol, I wouldn't have just accepted that and keep my mouth shut. [Sakura paused.] My parents-in-law strongly believed that alcohol cannot kill people. There was no way they imagined something like this would happen to their son."

-----It seems to me that their ignorance of the danger of alcohol dependence syndrome was a problem, too. Perhaps society in general has to be aware of this disease, too.

"Yes, I think there is that aspect, too."

If one can live one's life over again

-----Suppose you can live your life over again. How far would you like to go back and what would you do?

“I want to go back to the day when our business started becoming busy. I wish we hadn't expanded our business. These days, I question myself whether expanding our business was good. Maybe it would have been better if we had done our business with only one shop. Simple life may have been better....without flashiness, aggressiveness, and busyness. Why were we so obsessed about expanding our business? Right now, I am operating only one shop with my children. It's okay. It's really enough to live without any problem. Why did we expand, invest, and go through life without any spare time? At that time, while I was working in one shop, he was working in a different shop. We didn't have sufficient time to communicate with one another... Why did we do that? If we hadn't expanded our business, maybe my husband wouldn't have drunk that much and ended up dying. That's what I think these days.”

From the beginning to the end, while Sakura related her story she was wiping big tears from her eyes. Although crying, she kept talking with a smile and saying [or justifying] “Sometimes when the tension goes away, [I can't help crying like this].” This was the precious story of Sakura's husband who will never come back again, the story of Sakura's life with her husband which for sure had bad moments that cannot be recalled anymore.

Case 12. Family Environment Peculiar to the hardworking and successful husband

Name					Age		Occupation							
Akiko Takahashi					62		Takahashi Car Repair Company (accounting)							
Family							Husband's Occupation							
Nuclear <input type="checkbox"/> <input checked="" type="checkbox"/> Extended			# of members		5 (now) 6 (past)		Takahashi Car Repair Company (manager)							
Family members														
Taro		Husband			66									
Akiko		Wife			62									
Kazue		First daughter					Refuse to go to school.							
Tsugie		Second daughter												
Hatsu		Taro's mother					Deceased (several years ago)							
Total Interview Time					Wife Attending Self-help Group?					Husband Attending Self-help Group?				
1 hour 50 minutes					Yes <input type="checkbox"/> No <input checked="" type="checkbox"/>					Yes <input type="checkbox"/> No <input checked="" type="checkbox"/>				
Wife's KAST concerning her husband's alcohol related behavior (See Appendix 1 on Page 546)														
1	2	3	4	5	6	7	8	9	10	11	12	13	14	Total
<input checked="" type="checkbox"/> 3.7	<input checked="" type="checkbox"/> 3.2	2.3	2.2	2.1	1.7	1.5	<input checked="" type="checkbox"/> 1.2	0.8	0.7	0.7	0.6	0.5	<input checked="" type="checkbox"/> 0.5	≈ 6.4
-1.1	-1.1	<input checked="" type="checkbox"/> -0.8	-0.7	<input checked="" type="checkbox"/> -0.7	-0.4	<input checked="" type="checkbox"/> -0.5	-0.2	<input checked="" type="checkbox"/> -0.2	<input type="checkbox"/> 0	-0.1	-0.1	<input type="checkbox"/> 0	0	
?	?	?	<input type="checkbox"/> ?	?	<input type="checkbox"/> ?	?	?	?	?	<input type="checkbox"/> ?	?	?	?	
Analysis (See Analysis on Page 489)														
<input checked="" type="checkbox"/> A1	<input checked="" type="checkbox"/> A2	A3	<input checked="" type="checkbox"/> A4	<input checked="" type="checkbox"/> A5	<input checked="" type="checkbox"/> A6	<input checked="" type="checkbox"/> A7	<input checked="" type="checkbox"/> B1	<input checked="" type="checkbox"/> B2	<input checked="" type="checkbox"/> B3	B4	<input checked="" type="checkbox"/> B5	B6	<input checked="" type="checkbox"/> G1	
<input checked="" type="checkbox"/> C1	<input checked="" type="checkbox"/> C2	C3	<input checked="" type="checkbox"/> C4	<input checked="" type="checkbox"/> C5	<input checked="" type="checkbox"/> C6	<input checked="" type="checkbox"/> C7	D1	D2	D3	D4	<input checked="" type="checkbox"/> D5	D6	<input checked="" type="checkbox"/> D7	D8
E1	<input checked="" type="checkbox"/> E2	E3	<input checked="" type="checkbox"/> E4				<input checked="" type="checkbox"/> F1	<input checked="" type="checkbox"/> H1		<input checked="" type="checkbox"/> H2	H3	H4	<input checked="" type="checkbox"/> H5	<input checked="" type="checkbox"/> H6
Types of Problems (See Analysis on Page 489)														
<input checked="" type="checkbox"/> Verbal Abuse			<input checked="" type="checkbox"/> Physical Abuse			Financial		Psychological			<input checked="" type="checkbox"/> Shirinugui		<input checked="" type="checkbox"/> Child-Related	
Note														

Akiko Takahashi

Akiko is a wife of the manager and owner of the Takahashi Car Repair Company. The company, built by her father-in-law, is quite prosperous and employs many workers. Behind this successful business, however, is the busy home environment peculiar to a family which owns and operates a prosperous business.

Akiko related her tragic story extremely fast [like a machine gun!]. And from the beginning to the end, she repeatedly laughed loudly which made me reflexively laugh as well, despite the fact that the story was tragic and far from being laughable. Since I have encountered many interviewees who told their stories in this manner, I became curious about this behavioral pattern. So one time, I asked her when she laughed loudly:

-----Wait, Akiko, this is a terrible story! How come you laugh so much? I wonder if it is our nature [or maybe Japanese people's behavioral pattern] to say things comically when we relate terrible experience about ourselves...

When I said this, Akiko made a serious face and replied:

“Perhaps you are right. There is certainly a feeling in me which is like ‘I can't talk about this without laughing.’”

For me, interviewing Akiko was a pleasant time since there was much laughter and many jokes. It was however also an interview which raised a big question in my mind when I was looking at the data afterwards: ‘Why was I laughing so much at that time?’

How Taro Met Akiko

-----How did you become acquainted with Taro and get married?

“It was an arranged marriage. My sister was running a store, and Taro was the nephew of a good customer of that store. The conversation for the marriage proposal emerged from such a situation. Before asking me about my feelings—like ‘yes’ or ‘no’ to marry Taro—things were progressing without me, and when I finally noticed this, I was already in the situation of I must marry him [Akiko laughed]. Taro was already from that time a busy person and so didn’t spare time for our relationship. Before our wedding, I met him only once! It was so horrible that I wrote a letter to him saying that ‘I can’t marry you under such a circumstance.’ [Akiko laughed.] His mother, who sympathized with me, therefore invited me to her house and cooked a fancy foreign dish for me. Foreign dishes [Western style dish] were quite unusual at that time. Confronted with such kindness, I felt she was a kind woman and an amazing person.”

Taro’s father died of apoplexy [alcohol related] when Taro was still only nineteen years old. Since then, he has been the manager of Takahashi Car Repair Company. The marriage was arranged when he was 26 years old, which was about 6-7 years after he became the manager.

-----Were you informed about his drinking habit at all?

“No. Well, since I was raised in a non-drinking family, I didn’t bother about this kind of problem at all in the first place. Since my dad was also operating a self-owned business with 9 children, he was too busy to drink. I have almost never seen my father doing *banshaku* [drinking with meal] in my life.”

Husband's drinking habit (part 1)

-----What kind of person is your husband?

“If he doesn’t drink, he is gentle and quiet. Appearance-wise, he has a well defined features, the so-called *yasa-otoko* [nice-looking guy] [Akiko laughed]. People often say to me, ‘you have a good looking husband’ [Akiko laughed]. He also works a lot. In addition to his good performance as a manager, he is also good at taking care of his workers beyond their job. He sometimes visits the deceased workers’ tombs, too. In addition...perhaps he just likes having power...he is also the president of the car mechanics’ association of the Tohoku region. In any event, he is a busy person. For example, more than 10 years ago, although he was sent to hospital for cancer, he kept working hard and giving suggestions to the employees even from the sickroom. At that time, my work was to bring him the work-related messages to the hospital. He couldn’t just lie in bed and be hospitalized. [Akiko laughed.]”

-----You just used a conditional term “if he doesn’t drink.” Are you saying that his character changes when he drinks?

“I’m not sure whether drinking makes him become a sharp thinker or not, but when he drinks, he becomes very picky and gets angry over very small things: ‘there is not enough relish [for drinking]!’; ‘the garage’s light bulb is out!’; ‘the hem of the pants is lose!’; ‘a button on the shirt is missing!’ etc. [Akiko laughed.] Occasionally, he brings up old stories which I have even forgotten and lectures me. When my mother-in-law was still alive, it was her role to listen to his

complaints; but now that she is gone, it's me who has to take over that role. 'It is not supposed to be this,' 'That is wrong'... He sometimes complains about things to me which he wasn't able to say to the proper person before. Honestly speaking, I don't want him to bring work-related problems to the home. [Akiko laughed.]”

-----How does he drink? Tell me about his drinking habits.

“During the Japanese economical boom, he often drank outside. But that was still only once or twice per week. He is strict when it comes to money; playing merrily is not his thing. Most of the drinking, which he did in a relaxed manner, was done at home. He was doing *banshaku* [drinking with meals, often at home, see glossary on page 554] every day. In our house, we have a kit called *kan-petto* [Japanese sake bottle heater] which warms the *sake* to the right temperature. [Akiko laughed]. Using that, he drank two bottles every day. No *kyukanbi* [the resting day for the liver = no drinking day, see glossary on page 556]. Usually I warm the first two bottles for him, but when those weren't enough, he sometimes took the 1 *sho* [≈ 1.8 liter ≈ 0.48 gallon] *sake* bottle to his seat and was pouring it by himself.”

-----For *banshaku*, did he eat something or was he just drinking?

“I made him various relish dishes all the time. My husband cannot stand alcohol without foods: a meat dish, a fish dish, a cooked dish, a pickled dish, etc. I prepared *sashimi* [raw fish] for him every day. Often I worry about his relish more than the family's dinner because it's a problem when he isn't satisfied with the relishes. When this happens, I had to ask for delivery, such as *sushi* [expensive dish], for him. [Akiko laughed]”

-----You are a diligent wife!

“Well... we had many workers working at our place. So we are used to taking delivery in general. In addition, there is a *sushi* restaurant right across from our house. So, they didn't mind delivering to our house even for just one serving.”

Mother-in-law

-----Your husband sounds like a very picky person.

“My husband was raised by an extremely strict mother. Because my mother-in-law went through a lot of difficulties since she was young, she is a strong spirited person with quite a bit of endurance. Since he was raised by such a firm mother, he has high expectations not only from himself but also from others, too. He frequently scolds employees if their performances don't meet his standard.”

-----What kind of person is your mother-in-law?

“She passed away a long time ago. She was great. She didn't come out to the public and show off how hard she was working but rather worked hard without being noticed by others. Her life story was not necessarily a happy one since she encountered many troubles in her life. For example, her mother married three times which was rare for woman of that time. Also, she was put out to service [*houkou*] since she was a child. And although she got married, her husband had two illegitimate children with a lover [Akiko laughed with a troubled face]. That problem was solved

by giving them part of the property when my father-in-law passed away, though. In addition to that, of her twelve children only two survived to adulthood. It seems like she couldn't produce milk to nurse the infants. When my father-in-law died, the family debated who should become the manager, Taro, my husband, or my mother-in-law. She was such a capable woman. In the end, my husband became the manager. Although this was the case, she supported him in the background which was crucial for his success in business. Not only did she support the work outside, but she also did the housekeeping work perfectly, as well. She was going to a cooking school, and, as I said before, frequently made very fancy dishes.”

-----A woman tougher than *Oshin*? [I was half joking] [*Oshin* is the main character of the popular NHK television series of the same name. The drama is the life story of the successful peasant girl, Oshin, who was born in the Meiji period—from 1868 to 1912—sold by her poor parents and encounters many difficulties but overcomes them due to her determined spirit. It was originally released in Japan in the 80s but has become popular again these days because of its popularity in other Asian countries. At the time of the interview, Oshin was rebroadcasted daily in Japan.]

“Yes. She was much tougher than Oshin. So, meeting her standards was very tough for me too. [Akiko laughed.] For example, she made me polish the ceiling! If there was a tea stain on a tea cup...boy! That was a big problem! I had to bleach the cup immediately. [Akiko laughed.] For every meal, I had to place chopsticks at each person's place... You see...people in this family are very meticulous. They notice the difference immediately when the position of the pencil in the desk drawers changes [Akiko laughed]. Anyway, since mother-in-law was the one who managed the house, I worked really hard, almost on a stubborn level, in order to be the good daughter-in-law.”

No indulgence for *uchimago* [children of one's heir-apparent] and married-in-wife

-----It doesn't sound like she was a sly person who demanded a lot of you while she didn't do anything. She seems to have had high standards where she was strict not only to people but especially to herself.

“Yes, you are right. She never cheats or deceives others and uses it to her own advantage.

Well...that isn't completely true though... I remember she was treating herself well. I knew she was secretly eating special health foods such as the special royal jelly and the expensive Chinese teas. Although my children found out and asked for it, she never gave it to them.

Talking about the preferential treatments, she also showed partiality to my husband; she just doted on him. She served special delicacies only to him for dinner; took delivery only for him; and allowed only him to travel to South-East Asian countries... I wonder if she did this because he was her son, or because he was a hard working man who earned the household money. By the way, since she was the one controlling the household check book, I went through a lot of difficulties. For example, my dream was to let my children wear nice clothes or take after-school lessons such as playing piano or doing gymnastics, just like any other parents around here. But since my mother-in-law was an extremely thrifty person who didn't find importance in such luxury and uneconomical things, I couldn't do it. The only thing I was able to do was to let the children learn the Japanese abacus by a very generous teacher who taught two of my children for the price of one.”

-----I thought your house was well off, wasn't it?

“Yes, and that’s the problem. Although we weren’t short of money, my mother-in-law was always extremely strict, especially to our children. She is quite lenient and kind to her *soto-mago* [children whose parents are not heirs of the household], though. Whenever she had coupon tickets for places like amusement park or local events, she always gave them to the *soto-mago*. Good things were rarely given to my children.”

-----That’s unusual. I thought usually the *uchi-mago* [children whose parents are the heirs of the household] are spoiled and the *soto-mago* are not.

“Right. Somehow, however, she was always strict to the *uchi-mago* and me, the bride.”

A wife who does not complain

-----Treated in such a way must been upsetting for you. By the way, have your complaints to your husband about your mother-in-law caused a dilemma for him, which consequently led him to drink out of frustration?

“I don’t think that applies to my case. My position at home didn’t allow me to complain about things. In addition, although I suffered a lot because of the bad relationship with my mother-in-law, I almost never grumbled or vented my anger towards him.”

-----Was there anyone surrounding you to whom you could release such daily frustrations?

“No. But if it exists, those would be the people in my parental home. Since I had many siblings, I sometimes consulted my brothers and sisters when I was having difficulties. [Akiko paused.] There was a situation once, when I was still young, where I couldn’t stand this house anymore so I ran away to my parents’ house using a taxi. [Akiko laughed.] I wonder why I did that... [Akiko looked as if she were trying to remember it.] It was because of the fight between my husband and me. Anyway, I’m sure it was because of something very stupid. Oh yes, I remember! I said ‘you *shuran* [frenzy drinker]!’ to him and he scolded back, ‘Hey! What do you mean by calling me *shuran*!!!’ [Akiko paused.] I had to sit square on the floor and was scolded. I thought, ‘Why? Why do I have to go through this despite the fact I am making such efforts every day?!’ And that’s the reason I left the house. Unfortunately, I had to come back after all, though. The reason was simply because of the children. I had two children: 0 and 1 year old. Thinking ‘it’s not the time for me to get angry and make a fuss,’ I came back home. Although I didn’t possess a bit of love towards my husband, my duty to raise the kids and the disapproval of the idea that I would have to leave the kids in that house if I were to leave were very strong. Since this incident, I have never thought of running away from the house.”

Fortune-telling

According to her story, her brunt of dissatisfaction is directed more towards her mother-in-law than towards her husband. To avoid misapprehension, Akiko is not a lazy person. Instead, she is rather a perfectionist [and competitive] type who tries not have any fault on her side. It is possible that there are people who take advantage of her hard-working character; as she says, “I am a fool since I am incapable of cutting corners.” Her mother-in-law and her husband may have done this.

-----It's surprising that you don't complain.

“I occasionally go to see fortune-tellers. My friend likes that kind of thing. Anyway, according to the fortune-tellers, the compatibility between my husband and me is ‘the worst.’”

----- You consult fortune-tellers?

“I have consulted *jikaku* fortune tellers [fortune tellers who use the method of consulting the number of strokes in the client's name's Chinese characters.], too. I took my official seal [stamp, official signature in Japan] to the famous *jikaku* fortune teller one time. According to him, my husband's name is excellent, both last-name-wise and given-name-wise. Thinking about it, it is true. He has property. Although many of the rival companies went bankrupt because of the bad economy, ours somehow survived. By the way, contrary to his name, my name is hopeless according to him, both maiden-name-wise and current-name-wise. According to him, it is better to just follow my husband without opposing him. Saying ‘yes’ all the time seems to be what I should be doing. So, that is what I am doing.”

Husband's drinking habit (part 2)

-----When did your husband's drinking problem worsen?

“My husband got cancer [not related to his drinking] in 1989 from which he recovered. His drinking was most severe after he recovered from the cancer [early 1990] until our physician told him to cut down his drinking in 1996. I remember he abstained for a while, like for two weeks or so.”

Akiko took out a notepad on which she had jotted down Taro's medical history. She had made it for this interview.

-----What do you think was the cause of his increase in alcohol consumption?

“Perhaps the strain he had been under was relieved. It was the period of relief for him since our children got married and we now had an heir for the company/house. In addition, the accountant who used to be responsible for the company's budget retired. This man was a good employee, but he was also very strict and tight on the budget. He was a person of absolute integrity. For example, he never allowed us to buy anything for the house using the company's money, not even a broom. After his retirement, Taro suggested to allot more budget for *settai* [business related receptions, see glossary on page 556], which increased his opportunity to drink outside. Since he is a frugal person, this, only meant he increased the drinking opportunity to 1-3 times per week, though. At that time, he was also drinking about three *gou* of *sake* everyday at home.”

-----Has he ever skipped work because of the hangover?

“No, he always goes to work. He has never missed a day from work because of a hangover. At our house, the workers gather early in the morning every day. So, when he was ill, there were occasions when he rested for one or two hours after the gathering finished. But, truly, I have never ever seen him missing work for a whole day.”

Alcohol related problems

----Has your husband abused you physically when he was drunk?

“There was one time when he strongly punched me when I charged at him because he put down my efforts. And there was one time, also, when he threw something at me and so the house was damaged. [It seems like the object did not hit her.] In terms of ‘violence’...I think that is pretty much it.”

-----How about verbal abuse?

“He did that frequently. He becomes tedious when he is drunk. ‘Bring the drinks more!’ and so on. Because of this, when I serve his drinks, I usually try to leave the place.”

----What kinds of things did he say besides that?

“They are always small things, such as ‘you are not promptly and accurately conveying the work-related message to me!’ I also don’t like him scolding at me when I come home later than I was expected to.”

-----Does he hit his fist on the table in order to make his point?

“Oh yes, he does that often.”

-----How about overturning the table during meals?

“No. That rarely happened. My husband doesn’t vent his anger on objects in general. [Moment of pause.] By the way, no matter how harsh our quarrel is, my husband always asks for his meal. Even if we haven’t reconciled yet, he still asks for the meals, three times per day, and eats them.”

-----Well, isn’t that a good thing? It seems like the meal is giving you the opportunity for reconciliation....

“Do you think so? Well...I don’t know. [Akiko smiled and tilted her head to one side.] My honest feeling is that we are so busy that we don’t even have time to have a proper fight.”

-----A busy life is indeed a tough life. By the way, have you ever received a call from a bar saying “Your husband is too drunk to go home alone. Could you come and pick him up?”

“No, I haven’t. No matter how deadly drunk he became, he always arrived home by himself. He often used the taxi. Of course, I happen to see him lying on the living room floor since the strain to reach home safely was removed at the moment he entered the house.”

-----When that happens, do you help him go to sleep, for instance by taking him to the bedroom, removing his clothes, and making him wear pajamas?

“I don’t think so... I did put a blanket on him when he was lying in the living room, though.”

-----Was there any “effluence accident” because he was drunk?

“I am not sure this could be called the effluence experience, but he has made a mess in the toilet because he was drunk once.”

Husband’s current drinking habit

----How is his alcohol-related drinking habit now? Is he abstaining, or is he still drinking?

“He is currently drinking. Oh, but his drinking habit mellowed down quite a bit compared to the past. When he was told by the home doctor to abstain, he didn’t drink a drop of alcohol for two weeks! That was really amazing. [Moment of pause] These days, he drinks *mugi-shochu* [distilled wheat liquor] every other day and *sake* in between. He drinks about 2 *gou* [≈ 0.36 liter ≈ 0.09 gallon] per day. No *kyukanbi* [resting day for the liver, see glossary on page 556]. These days, he uses the microwave to warm his drinks by himself. He watches television and drinks.”

----Are you still preparing many elaborate relish dishes for him?

“Yes, but his taste changed significantly, though. In the past, he preferred deep fried dishes such as *tonkatsu* [fried pork coated with egg and bread crumbs], but he likes plain and simple dishes these days: vegetables, *sashimi* [sliced raw fish], cooked dish, *sunomono* [ingredients marinated/pickled with vinegar] etc. He eats *kim-chi* every day. He sometimes eats ascidian [a sea squirt], too. He seems to be very concerned about his health. For example, these days, he drinks *umeboshi-cha* [pickled Japanese apricot tea] every day. He bakes the apricot and puts it into the tea. Since he is a man of strong intention, if he decides to do something, he will do

exactly that persistently. He is doing this every day. In addition, he is eating a perilla *miso*-soup every day. Did you know that perilla is very good for your health? I saw it in *Mino-Monta*'s television show³⁰ [Akiko laughed]"

-----Are those any good?

"Oh yes. His health seems superb."

According to Akiko, Taro recently started walking as an exercise, too.

-----Akiko, do you think your husband has a problem when it comes to drinking?

"No. I don't think he has a problem. His health is not really damaged, I believe. I sometimes think it would be better if he had *kyukanbi* [resting day for the liver, see glossary on page 556], though."

Husband's drinking and his family members surrounding him

Taro's hard-working habit and his environment may not seem to relate to his drinking at first glance. Such an environment, however, is not entirely unrelated to his drinking behavior. In this house, because the household is busy but also very successful, there is an attitude which permits or even encourages drinking—which provides instant pleasure—for Taro. The family members

³⁰ A popular morning television show targeted at housewives which gives tips on various ingredients for meals. Japanese grocery stores are also influenced by this show; the ingredient covered on the day's show tends to sell well and sometimes even sells out immediately.

surrounding him carry the idea “As a hard-working father, who sacrifices himself for the family, why can’t we at least let him drink and enjoy his modest entertainment?” This can be seen in Akiko’s behavior, as described above, who does not perceive her husband as a problem drinker.

In this respect, I see the similarity between this case and Sakura Kobayashi’s case [Case #11: A successful and hard working husband who died because of his alcohol dependence syndrome]. Both men drank to remove their tension after work, which appeared as no problem to the family members. In addition, they were also far from the stereotypical bankrupt alcoholic family but rather had a respectable hard working family environment. In these cases, one of the major problems lies in the family’s ignorance of the nature of alcohol dependence. By not knowing about it, they allowed or even encouraged the father/husband’s drinking and supported his drinking habit. Family members must understand that “although he sacrifices his life for the family, excessive drinking is a different matter.” Remember—this ignorance killed Sakura’s husband.

Case 13. Many successful abstainers' wives also participate in *Danshukai* (Japanese self-help group) meeting.

Name		Age	Occupation												
Takako Segawa		72	Librarian at the prefectural library (retired)												
Family			Husband's Occupation												
Nuclear	Extended	# of members	5												
			Salesman for well-known Japanese enterprise												
Family members															
Ichiro	Husband	68	Diagnosed with alcohol dependence syndrome, Alcohol related incident (police involved)												
Takako	Wife	72													
Kazuko	Daughter														
Total Interview Time		Husband Attending Self-help Group?		Wife Attending Self-help Group?											
2 hour 20 minutes		Yes No		Yes No											
Wife's KAST concerning her husband's alcohol related behavior (See Appendix 1 on Page 546)															
1	2	3	4	5	6	7	8	9	10	11	12	13	14	Total	
3.7	3.2	2.3	2.2	2.1	1.7	1.5	1.2	0.8	0.7	0.7	0.6	0.5	0.5	≈15.7	
-1.1	-1.1	-0.8	-0.7	-0.7	-0.4	-0.5	-0.2	-0.2	0	-0.1	-0.1	0	0		
?	?	?	?	?	?	?	?	?	?	?	?	?	?		
Analysis (See Analysis on Page 489)															
A1	A2	A3	A4	A5	A6	A7	B1	B2	B3	B4	B5	B6	G1		
C1	C2	C3	C4	C5	C6	C7	D1	D2	D3	D4	D5	D6	D7	D8	
E1	E2	E3	E4				F1			H1	H2	H3	H4	H5	H6
Types of Problems (See Analysis on Page 489)															
Verbal Abuse	Physical Abuse	Financial		Psychological	Shirinugui	Child-Related									
Note															

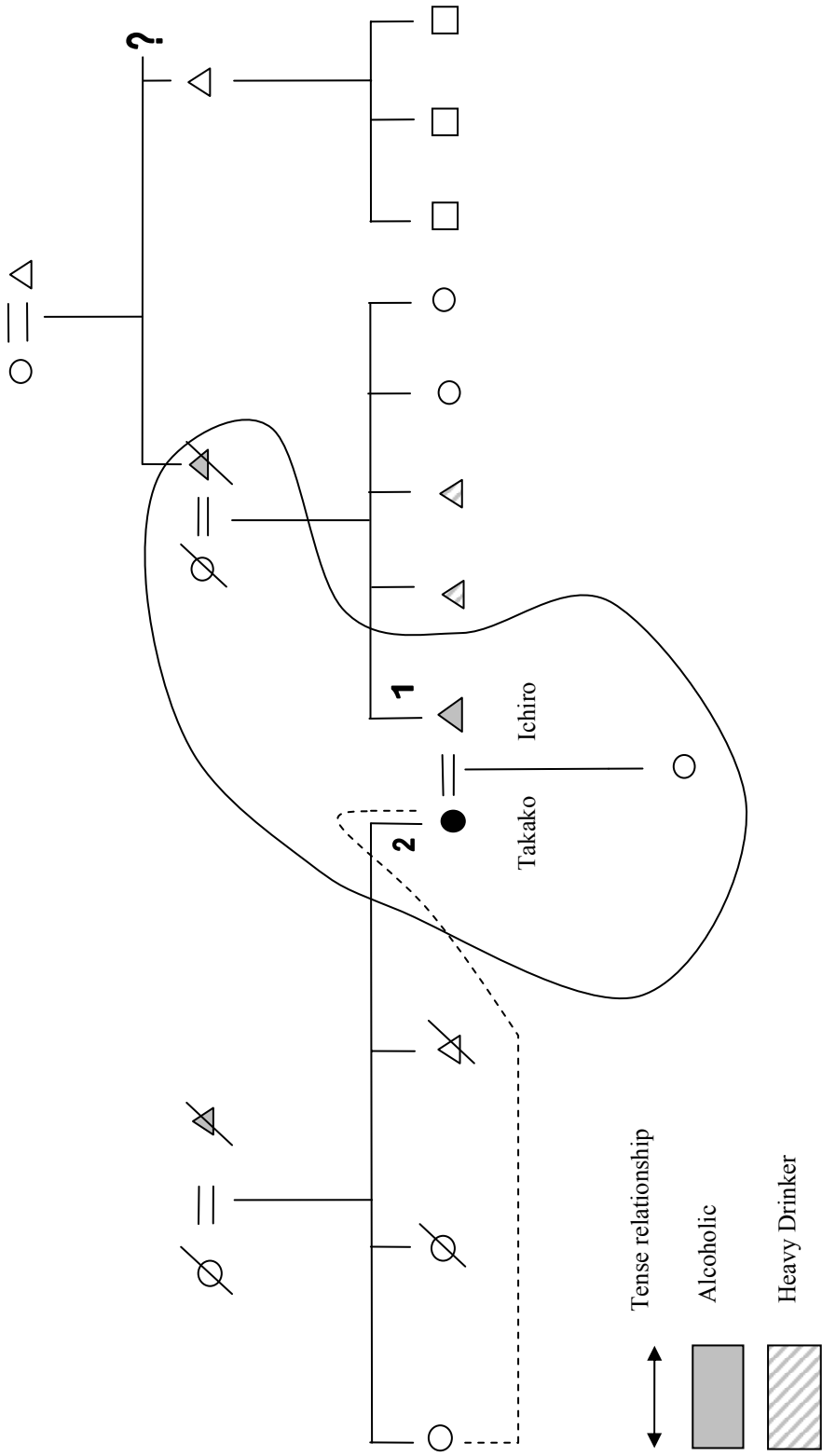

Takako Segawa

Perhaps since she had been working outside for a long time, Takako appears professional—she wears a nice looking suit. She appears to be in her early sixties rather than her actual age of 74. Her way of talking is calm and logical. Coincidentally, I have met her necktie-alcoholic husband—Ichiro—as part of a previous study more than five years ago. I

remember he was an unusually kind and polite man, smiling all the time. His hobby is reading books from a broad range of genres. I remember talking with him about ‘the World treasure’ in which he was interested at that time. My impression of Ichiro, was, honestly, quite positive. For this interview, however, I tried to suspend the previous impression; my task was to understand Takako’s perspective as his wife, which quite possibly is very different from how he is perceived by people in general.

The beginning of their married life

Takako and Ichiro’s families were neighbors; they passed each other the local community’s circular notice³¹ and helped each other when needed. Takako married the four years younger Ichiro when she was thirty-three years old. She says that the marriage was “something like a love marriage, certainly not an arranged marriage.”

-----How did you see Ichiro’s drinking habit at the beginning of your married life?

³¹ Circular notice (*Kairan-ban*): Notice that gets passed from house to house in a small community.

“There was seldom a problem. I would say he drank ‘*tashinamu teido* [some].’³² Since I worked outside, I have seen many men drinking outside as an extension of their work. Some drank and got deadly drunk... Since I was familiar with this kind of drinking custom, I didn’t think that Ichiro was a particularly deviant drinker. In fact, I remember he didn’t have much trouble compared to the troublesome drinkers I witnessed at that time.”

According to Takako, Ichiro was drinking ‘normally’ during the first or second years of their married life. This means that he was drinking outside with his work-related mates [e.g. colleagues and customers] every night.

“I thought ‘this is the way men drink.’ They drink after work and become talkative... And through this they release their stress... I always thought that this is the way it is for men.”

As described, since Takako had encounters with many drinkers like Ichiro as well as drunks whose drunken behaviors were much worse than Ichiro’s, she never regarded her husband as particularly problematic. Even now, she does not think that the current way of men’s drinking as well as Ichiro’s way of drinking at that time is “weird” or “wrong.”

Problem drinking--part 1

-----Tell me about the first time you noticed his alcohol problem.

³² The expression *tashinamu teido* is commonly used by Japanese for the amount of alcohol they drink: “I drink *tashinamu teido*.” As the literal meaning 'at the level of enjoying' indicates, this expression is very ambiguous where the amount can differ significantly. Throughout this study, when the interviewees used this word for describing their husband's amount of drinking, I asked for more specific information.

“It was about five or six years after we got married. He drank at home after he came back from drinking outside. This is something he commonly used to do in the past, too. The problem was that until then he used to drink only one *gou* [≈ 0.18 liter ≈ 0.05 gallon] of sake but now this amount was not enough for him anymore.”

In terms of work, Ichiro was a hard-working man, perhaps more than other colleagues. He didn't grumble about his work when drunk nor missed work because of a hangover.

According to Takako, it seems there was no physical abuse, either.

-----Could you tell me about the time when you became sure that he had a drinking problem?

“The time I constantly started worrying about his drinking was several years after the first time I noticed his drinking problem. It was probably when he was in his mid-forties or so. He returned home later and later. He started hopping bars. Occasionally he came home deadly drunk. He started skipping work because of a hangover, too. Once he took the mandatory health examination and was told that his liver was in a bad condition. From around this time, he started to become hospitalized about one week every time. At that time, his boss was not yet aware of his drinking problem.” [The boss did become aware of Ichiro's drinking problem later.]

Traffic accident

One day, around that time, Ichiro caused a traffic accident. At midnight when he was walking back home drunk like usual, he ignored a signal and was hit by a car at the crosswalk.

“I received a phone call from a hospital saying ‘Your husband, Ichiro, was caught in a traffic accident. Please come immediately.’ That night, I remember I heard the sirens wailing from the house and thought ‘Oh no... Someone may have gotten injured.’ It never occurred to me that that siren was for my husband. I went to the place of the accident. His glasses were lying on the road, rim bent and lenses broken. One of his shoes was there, too. It was a horrible sight. Fortunately, Ichiro’s injuries were not as bad as I thought. He hit his back which required him to stay in hospital for a while, though. Fortunately the driver who ran over him was a very kind lady; she frequently visited Ichiro at the hospital and apologized for what she had done.”

“I was the most exhausted, perhaps more than Ichiro himself...”

Since this accident, Takako started seriously worrying about her husband’s drinking problem. She began a lifestyle where she waited without sleeping for Ichiro’s return late at night.

“I anxiously waited for his return without sleeping every day. While waiting, only negative things came up to my mind: ‘What if he has caused a traffic accident again?’; ‘What if he became involved in some kind of trouble?’; ‘What if his disease becomes worse?’ Thinking

about those days now, I think I was very exhausted, perhaps more than the alcoholic Ichiro himself. When I noticed his return at the door, I was first of all relieved, although seeing his drunken behavior made me mad afterwards. By the way, the problem of the day did not end there. Since Ichiro hadn't had supper, I had to serve a meal to him. In addition, I had to prepare his bath. Since our bath uses gas to heat the water, I didn't want any accident caused by my drunken husband. It was too dangerous to leave him alone. I only slept after he had finished his bath and had gone to bed.”

Takako says it was common for her to go to bed at one or two o'clock in the morning.

She worked at the public library and had to go to work by 8:30 a.m. every day. Instead of rushing to work the next morning however, she commonly made sure her husband was okay and called his workplace if he was ill due to a hangover, before she left for her work.

“I frequently called his workplace and gave them excuses—'He caught a cold,' or 'He is not well today...'—so that he can be absent from work. They were mostly lies...”

When she couldn't get enough sleep during the night because of her husband's late return, she took a nap at the locker room at work during her lunch break. This was in fact part of her daily routine. Takako's daily schedule after this can be described roughly as follows. Her work ended at 5:00 p.m. she went home. Afterwards, she prepared dinner and ate with her family at 7:30 p.m.. This dinner of course did not include Ichiro. Afterwards she watched television or took a bath and relaxed. Then, from 9:00 p.m. to 10:00 p.m. (and

sometimes until 1 a.m. or 2 a.m.), she lay in bed and waited for Ichiro's return. She slept lightly, without changing to her night clothes. Then she waited for Ichiro to return and took care of him as described above. Takako states that she lived this way for at least fifteen years.

Drinking problem--part 2

Ichiro's missed work more and more often as time passed. Sometimes, he did not even come back home.

“He was staying at a business hotel near his workplace. Affairs? No, I don't think he had that kind of problem at all. He stayed in such hotels, drank and slept there, and on the next day he went to work from there. [Takako paused.] He was also going to places such as a 24 hour sauna. He seemed to be taking sauna to become sober and then drink again. Taking sauna to become sober... Where in the world did he learn such a thing...? [Takako looked troubled.]”

When Ichiro lacked money, Takako was called and asked to pay hotel bills for Ichiro. Sometimes Ichiro asked her to pick him up, too. Sometimes when she arrived at the hotel to pick him up, there was an effluence in the hotel room caused by Ichiro. Takako says there was almost no violence in the house. She said, however, that the door and the window glass were broken several times. There was not much verbal abuse, or grumbling about the workplace. It is worth mentioning here that Takako was trying to avoid Ichiro when he was drunk and because of this there was no physical or verbal abuse. Simply knowing that there

was no physical nor verbal violence may already portray an accurate picture of their relationship of that time. When Ichiro's disease worsened to the level of madness, Takako says there was almost no conversation between them. Although Takako did not talk to him, Ichiro on the other hand was saying many meaningless things "You stupid!" or "Shit!" to her—or perhaps to somebody else in his mind—in a very inarticulate manner.

Problematic bar for the wife

Ichiro was a regular patron of a certain bar. Takako told the bar's Mama about her husband's drinking problem and asked her not to let him drink too much and make him return home early. She told this to the Mama every time she visited the bar to pick up Ichiro. Takako had long believed that she was on good terms with this Mama. Her perspective, however, changed after one memorable incident...

"Selling drinks is their business. They [the bar's staff including the Mama] show sympathy for my problem, but they weren't as supportive as I expected. One day, when I went to the bar to pick up Ichiro, he was hiding in a small private room at the bar. Here is the story. I went to the bar like usual and asked if my husband was there. Mama said that he was not there. Indeed, there was no Ichiro when I looked around the bar. But, then I happened to notice his coat hanging at the wardrobe. I said to Mama, 'Are you hiding my husband? Let me see him!' Then I saw Ichiro coming out from the room reluctantly. I was surprised. Probably, when they noticed that I came to the bar, Mama allowed him to hide in that room at once. I had a word with Mama afterwards."

There was also a money related trouble with this Mama, too. Ichiro guaranteed a loan for one million yen [\approx U.S.\$9,091] which was for Mama's expansion of her business. It was hard for Ichiro to say "No." Since the bar was a good customer of Ichiro as a salesman, being on good terms with them was important for Ichiro's work. Ichiro frequently drank at that bar without paying. According to Takako, Mama seemed to start deducting the unpaid bill and its interest from the one million yen which he had guaranteed. And as the time went by, the unpaid bills increased. At the same time they had to pay a significant amount of money as guarantors of the loan. Ichiro was not the only guarantor of the loan, Takako was also named as guarantor. When Takako noticed that she had to pay such a large amount she couldn't believe what was happening. She decided to talk with Mama directly.

"Realizing that Ichiro is of no use, I went to Mama's place and talked with her face to face. After a long discussion, I promised her that I will pay the unpaid bills and their interest. At the same time, I asked her to pay off the rest of her loan herself. I fixed the problem in some way so that the damage did not increase any further. Even so, I believe we paid about half of the amount Ichiro had guaranteed."

The call from the boss and the company's reaction to Ichiro's problem

It was around the time when Ichiro was 50 years old. His drinking problem worsened and he missed work frequently. At that time, he could not even eat his meals properly; he was mostly just drinking. And finally, at last, his health worsened so much that he was not even able to drink his favorite alcohol.

One day at that time, Takako received a call from her husband's boss.

“His boss said, ‘Your husband is faultless in terms of work. But, these days, he frequently misses work without notice. And even when he comes, he smells like alcohol. Do you have any problem that I need to know of?’ It seems like the boss thought that this problem is induced by some problem in our marital relationship. I could no longer lie to the company anymore; I finally revealed our problem to the boss. I said to him: ‘My husband is an alcoholic. He can't live without alcohol anymore. I have been struggling with the problem for a long time, too.’ I related my story. The boss carefully listened to my story and sympathized. He sometimes muttered ‘It would be a scandal if there is a suicide in our company [Ichiro worked at a very well known Japanese company.]...’ After all, the boss said to me, ‘I will take this information to the top. I promise we will come up with some kind of solution.’ and we ended our conversation at that time.”

As she learned later, this boss gathered the section chief, the division chief, and some other important employees of that branch and held a meeting to come up with a solution for Ichiro's alcohol related problems. Through this, Ichiro's workplace came up with a plan for Ichiro's drinking problem, which involved many employees of the company.

The day to carry out the plan finally came. Takako was asked to tell the boss any bars Ichiro was likely to visit that night. She listed the bars one after another: on street A, there are bars X, Y, and Z; on street B, there are V and W; on street C, there are S, T and U... The employees participating in the plan were asked to stand-by at these bars and contact the headquarters immediately when Ichiro arrived. Right before the start, the boss

said to Takako, ‘Madam, we need you to wait for our call at home. Please be prepared to leave the house immediately whenever we call you.’ [Takako paused.] It was a little after 10 p.m.. I received the call ‘He’s found! He is at the bar V on street B!’ I was called to come to the headquarters immediately. So I went. When I arrived there, Ichiro and I talked with Mr. Miyazawa, his former boss, whom Ichiro trusted a lot. We talked about what he should do from now on. Mr. Miyazawa recommended Ichiro to consult a doctor and go through treatment thoroughly. So, the next day, we went to the mental health division of a hospital which Mr. Miyazawa knew very well. Mr. Miyazawa was kind enough to arrange everything for Ichiro to be hospitalized. Ichiro was diagnosed with alcoholic liver disorder and was told to stay in hospital for one month. In the hospital, we were informed by the doctor that there is a hospital in this region that specializes in alcohol treatment. Ichiro was recommended to consult the doctor there.”

Hospitalization

Takako says that this time was the donzoko [the very bottom] in her life. They went to the hospital the doctor had recommended and Ichiro was diagnosed.

“I still clearly remember that day. It was Saturday. Ichiro and I went to the hospital together. When Ichiro was called for the diagnosis, Dr. A said to me, ‘Mrs. Segawa, you can join, too. But please, refrain from interrupting our conversation.’ The doctor told Ichiro, ‘You have alcohol dependence syndrome. This is a curable disease. Whether it is cured or not, however, depends on you. Do you want to live long? Are you serious enough to overcome the disease?’ Afterwards the doctor said, ‘We do currently have a bed available, so we

could admit you here if you want. What is your preference?’ Ichiro had a dubious and unwilling attitude towards the doctor. I, on the other hand, wanted him to go through the treatment desperately. I persuaded Ichiro as much as I can: ‘Ichiro, the physician made an effort for you to get diagnosed and here we are now at the hospital. Let’s not waste other people’s efforts. Why don’t you accept this offer?’ and ‘This is the chance. Let’s make an effort together. I will support you, too.’ At that time, I was more desperate than Ichiro himself. Through our conversation, Ichiro finally replied, ‘Well... in that case, I could go in.’ At that time, since I didn’t expect him to become hospitalized, I wasn’t prepared for this at all. But as the saying goes—What is worth doing is worth doing promptly.—I promised the doctor that I will responsibly bring my husband to the hospital the next day [so please take care of my husband]. After we returned home, I was in a rush to prepare for Ichiro’s stay in the hospital. The next day, Ichiro was hospitalized, as planned.”

This was when Takako had just retired from her job.

“Fortunately, since I had more time than I used to, because of my retirement, I was able to take care of my husband more than I used to. During the hospitalization, Ichiro was forced to follow a well-regulated lifestyle. According to the hospital’s rules, patients were permitted to leave the hospital on Saturday and Sunday. Although Ichiro actually didn’t drink, I was very much worried about him taking advantage of these days and use them as an opportunity to drink outside.”

According to Takako, her husband's medical treatment was more painful than she had expected. As part of the treatment, he was locked into a single room. During the confinement, he saw hallucinations as part of his withdrawal symptoms. Since Ichiro never went through such an experience before, he was very much surprised with the tortures he went through. Unlike the medical treatment which was painful, his relations with the people surrounding him were non-problematic at all. Due to his serious and caring character, people trusted and relied on him a lot. After the successful three months hospitalization, he convalesced at home for a month and returned to work at his old workplace again.

Participating in the self-help group at the hospital

During Ichiro's hospitalization, Takako was recommended by the caseworker to attend the self-help group for the family held at the hospital.

“At the meeting, I learned that alcohol problems not only require the treatment of the alcoholic person's disease itself but also treatment of family members surrounding the alcoholic. The doctor told me, ‘Your task is to let the problems you went through out. This is your treatment.’ When I heard this, I doubted what he said and thought, ‘How can speaking out cure me?’ But now, I think he was right. As I spoke about my bottled-up feelings that I had accumulated over the years, I felt my negative feelings, my irritation, anger, and anxiety diminishing. It was something that I couldn't say to any other people, not even to my best friends or my parents. [Takako paused.] At the meeting, there were people whose face showed their tough life because of their family member's addiction problem. They related their horrible stories such as ‘I was kicked in this way, knocked in

that way, accused in so and so ways...’ I learned many things by listening to the stories of people whose experiences resembled mine. As you know, talking about such things requires a lot of courage. In the beginning, I was mostly listening to other people’s stories. But little by little, I became able to talk about my family’s problem, our alcohol problem, too.”

Ichiro drank again 2-3 times since this hospitalization. He is currently abstaining. It has been at least thirteen or fourteen years since he drank the last time.

The meaning of attending the self-help group

Attending the self-help group meetings during Ichiro’s hospitalization gave Takako the opportunity to start changing herself. And continuous attendance was crucial for the change to continue and become stable.

“Even after Ichiro’s hospitalization, I kept going to the self-help group meetings. At the beginning, Ichiro refused to go. But through my persistent persuasion he started to accompany me to the meetings. Since, then, regardless of bad weather—rain, wind, or snow—we have been going to the self-help group meetings. Whatever happened, I pulled his arms and went to the meetings at least twice per week. What I learned at the hospital’s self-help group was for me to recover from my co-dependence problem and become an independent person. Although I understood this in words, it was hard to act it out in my every day practice. I was frequently involved in his problems which I shouldn’t have been.”

The meaning of wives attending the self-help group

Takako believes that “the changes in the wife’s side is the key to the solution of the husband’s problem and moreover the solution to the problem in a broader sense.” And for this, she believes that the wives’ participation in self-help group meetings is a quick means to change themselves in the right way. Based on her experience, she states the technique for the husband’s success in abstinence as follows:

“I have participated in the self-help group meetings for many years, and, at the end, we served as the group leaders of a self-help group. Throughout my activities, I realized the influential position of alcoholics’ wives. I think wives’ attendance at self-help group meetings is very important. I have witnessed many cases where husbands fail to abstain since their wife stopped attending the self-help group meeting. It seems to me that if the wife’s awareness of the problem is strong, then her husband’s abstinence is more likely to succeed. Many successful abstainers’ wives tend to go to the meeting together with their husbands. I understand that the wives want to complain ‘Why do I have to go?’ Thinking back, when Ichiro was hospitalized, it was only me, as an alcoholic patient’s wife, who was attending the hospital’s self-help group meeting. It’s indeed not common for wives to attend self-help group meetings. However, one thing I can say to you is that ‘doing so will certainly pay back.’ It’s worth it.”

After Ichiro abstained for seven or eight years, he and Takako actively participated in self-help group operated events. Later, Ichiro became the leader of the local self-help group and Takako served as the sub-leader.

“Serving in these responsible positions was good for us, too.”

When Ichiro’s abstinence reached ten years, they decided take a step back from the active roles. They did this since they believed that Ichiro could live without alcohol. They are, however, still official members of the self-help-group and occasionally attend the meeting. They do so since they know that departing from it means one step closer to starting to drink again. Takako told me about the difficulty of abstaining without the help from the self-help group. She informed me about the recent incident where her self-help group friend, who was also serving as the chairman of the local self-help group, stopped coming to the meeting, drank again and died.

Peaceful husband-and-wife relationship

Takako says that they are currently spending a much stabilized married life.

“In the past, I was always worrying not to make him upset while talking to him. But now, I can say whatever I want. Our relationship in the past was very unhealthy. But now after we went through the treatment of our alcohol problems, our relationship changed to what one may call ‘a healthy marital relationship.’ I like the current situation a lot. These days, I still recall the days when my husband's colleagues were all recruited for the solution to his drinking problem. That event was amazing. I think it was very crucial for our lives, too. We were helped by many people. Without the incident, our current situation would probably not have been possible. [Takako paused.] Although I experienced various unforgettable

hardships, my feelings became easier and easier as I listened to other people's experiences and participated in alcohol problem related events such as study groups and public lectures. Through such activities and time, my vexations against Ichiro went away and it is almost lost by now. These days, I even worry about the likeliness of me forgetting all the suffering I have experienced in the past. [Takako laughed.] It is true that sometimes 'time solves the problem.'”

The causes of husband's drinking problem

-----Why do you think your husband drank so much?

“Well, he started drinking when he was twenty years old. The accumulation of his daily drinking habit is simply the reason for his inability to stop drinking.”

-----Could you think of any other cause besides this one that made him drink excessively and became alcohol dependent?

“Hmm [Takako looked like as she is thinking a lot]. Maybe the stress induced from his work?”

-----There are various kinds of work related stress: stress induced from bad relationships with colleagues or with the boss, failure to be promoted, etc. For example, do you think he had any problem in terms of promotion?

“No. Since Ichiro is not a university graduate, he seems to have given up in the competition for promotion right from the beginning when he started to work. He didn’t seem to have a strong desire for getting an executive position. Whenever his colleagues or his friend got promoted, he was happy for them, too. Ichiro is a kind person and people like him. He doesn’t create enemies. Because of that character, he had no trouble with bad human relations in general. He was liked by his boss, too. I think his work-related stress was induced by his failure to attain the company’s margin such as failing to attain a certain number of customers. I think rather the stress induced from such problems is the cause of his drinking.”

-----Do you think his drinking habit is related to some kind of inferiority complex?

“Yes. As I said, Ichiro had to give up studying at university. He spent his adolescence in the poor postwar period. Around WWII, he had to be separated from his parents and live with his uncle’s family. He was still in his early teens at that time.”

-----Do you think separation from his parents at such an early age induced some kind of incurable problem in him?

“Well, I’m sure it was hard time for him since it happened when he was quite young. But, many people lived like that at that time so he wasn’t the only one. I don’t think this experience created the problem that influenced the rest of his life.”

The conversation goes back to the topic of him giving up studying at university.

“Anyhow, when Ichiro was in high school, his parents closed down their business in Osaka and joined him. At that time, he had two sisters more than ten years younger than him. In such a poor family condition, an eighteen year old man was an important worker for the family. Although Ichiro was clever enough to enter the university, he had to quit and earn money instead. Since he had a strong urge to study, he took evening classes. During the day he worked outside and at night he took evening classes from a two-year college. After he graduated from the college, he started working for his current employer immediately. If he had gone to university... It seems like he wanted to become a journalist. I think his experience of having to give up his dream has long been part of the root of his drinking problem.”

-----Is there any quarrel between Ichiro and his parents for him not being able to go to university because of the financial situation of that time?

“He has expressed his grudges about this problem to me, but I don’t think he has ever accused his parents for it.”

-----Were Ichiro’s parents aware that his drinking was partially caused by these reasons?

“Yes. His parents were always apologizing to me saying, ‘I am sorry my son is causing you so much trouble. It is because the parents are so incapable and unreliable people.’ I used to

say to them, ‘Mother(-in-law) and father(-in-law)—it’s not your fault. It was common for many people of that time to have such problems like you. It was because of the societal situation and not you. You shouldn’t feel so guilty about it.’ Despite my words, however, they were still feeling guilty for what they did. They frequently apologized to me who was often busy cleaning Ichiro’s mess. In addition to this, they felt small for being taken care of by us. Because of all this, they felt uncomfortable pointing out his excessive drinking habit to him. They almost never touched the problem at all. They were in a sense enabling Ichiro’s drinking.”

-----Is there any possibility of a bad relationship between you and your mother-in-law being the cause of Ichiro’s excessive drinking?

“This is rare, but my relationship with my mother-in-law was unusually good. It’s almost like a real mother and child relationship. Grandfather is bit perverse [twisted mind], but that didn’t cause a bad relationship between us. We were in general on good terms and I don’t think this could have been the cause of Ichiro’s drinking.”

Takako’s advice

-----Could you give some advice to women currently troubled by similar problems as you were?

“First of all, it is necessary to recognize that ‘the family itself is sick.’ Secondly, it is important for those who surround the alcoholic, such as wife and children, to ‘recover from

the problem of co-dependence and become independent.’ It is especially important for these people not to get affected by the alcoholic’s drinking action [whether he drinks this day or not]. Also, never ever clean up his mess. Thirdly, ‘consult the doctor.’ The sooner, the better. Fourthly, ‘study about this problem,’ And fifthly, at last, it is important that ‘you listen to other people’s stories or speak up about your problems and release your bottled-up feelings, for example by going to self-help group meetings.’”

Takako concisely enumerated these pieces of advice all at once. I was surprised by this remark. She must have been helping other people based on this advice for a long time.

Those people who continuously attended self-help groups often say that doing so was good for them. On the other hand, there are many people who hesitate to go to these meetings. As described in other interviewees’ reports as well, the stereotypes of self-help groups—“gathering of stinky alcoholics” or “gathering of the losers of the society”—are an obstacle for many people to participate in them. Contrary to these stereotypes, self-help groups are in fact gatherings of many people who are quite pleasant: they are often serious, caring, hard-working, and most important, they are people who humbly face their problem squarely, which for many people is very hard to do. Since attending self-help group meetings seems to be the key for many successful abstainers, I feel helpless when I encounter people who show their reluctance to participate in these meetings with the common excuse: “I am too busy to go there right now. Maybe in the future” Contrary to the situation in the past where there was no self-help group meeting held in the region, there is a meeting almost every day somewhere in the region now. The environment is set to allow

people to start to turn around their lives at any time: now it only depends on people's choice whether they want to take responsibility for their lives or not.

Case 14. Wives have to take action from their side, too. It's their life. They are supposed to be responsible for their own lives. Suffering from anxiety caused by the possible doomed future alone is not good at all.

Name				Age		Occupation									
Nobuko Kikuchi				65		Part-time worker at a cafe									
Family						Husband's Occupation									
Nuclear		Extended		# of members		4-6		Civil engineer							
Family members															
Ichiro		Husband		67		Diagnosed with gastric ulcer, neurosis									
Nobuko		Wife		65											
Kazuko		First daughter													
Tsugio		First son													
Total Interview Time				Husband Attending Self-help Group?				Wife Attending Self-help Group?							
1 hour 40 minutes				Yes No				Yes No							
Wife's KAST concerning her husband's alcohol related behavior (See Appendix 1 on Page 546)															
1	2	3	4	5	6	7	8	9	10	11	12	13	14	Total	
3.7	3.2	2.3	2.2	2.1	1.7	1.5	1.2	0.8	0.7	0.7	0.6	0.5	0.5	≈19.9	
-1.1	-1.1	-0.8	-0.7	-0.7	-0.4	-0.5	-0.2	-0.2	0	-0.1	-0.1	0	0		
?	?	?	?	?	?	?	?	?	?	?	?	?	?		
Analysis (See Analysis on Page 489)															
A1	A2	A3	A4	A5	A6	A7	B1	B2	B3	B4	B5	B6	G1		
C1	C2	C3	C4	C5	C6	C7	D1	D2	D3	D4	D5	D6	D7	D8	
E1	E2	E3	E4				F1	H1	H2	H3	H4	H5	H6		
Types of Problems (See Analysis on Page 489)															
Verbal Abuse		Physical Abuse			Financial			Psychological			Shirinugui		Child-Related		
Note															

Her biological mother died when Nobuko was in elementary school

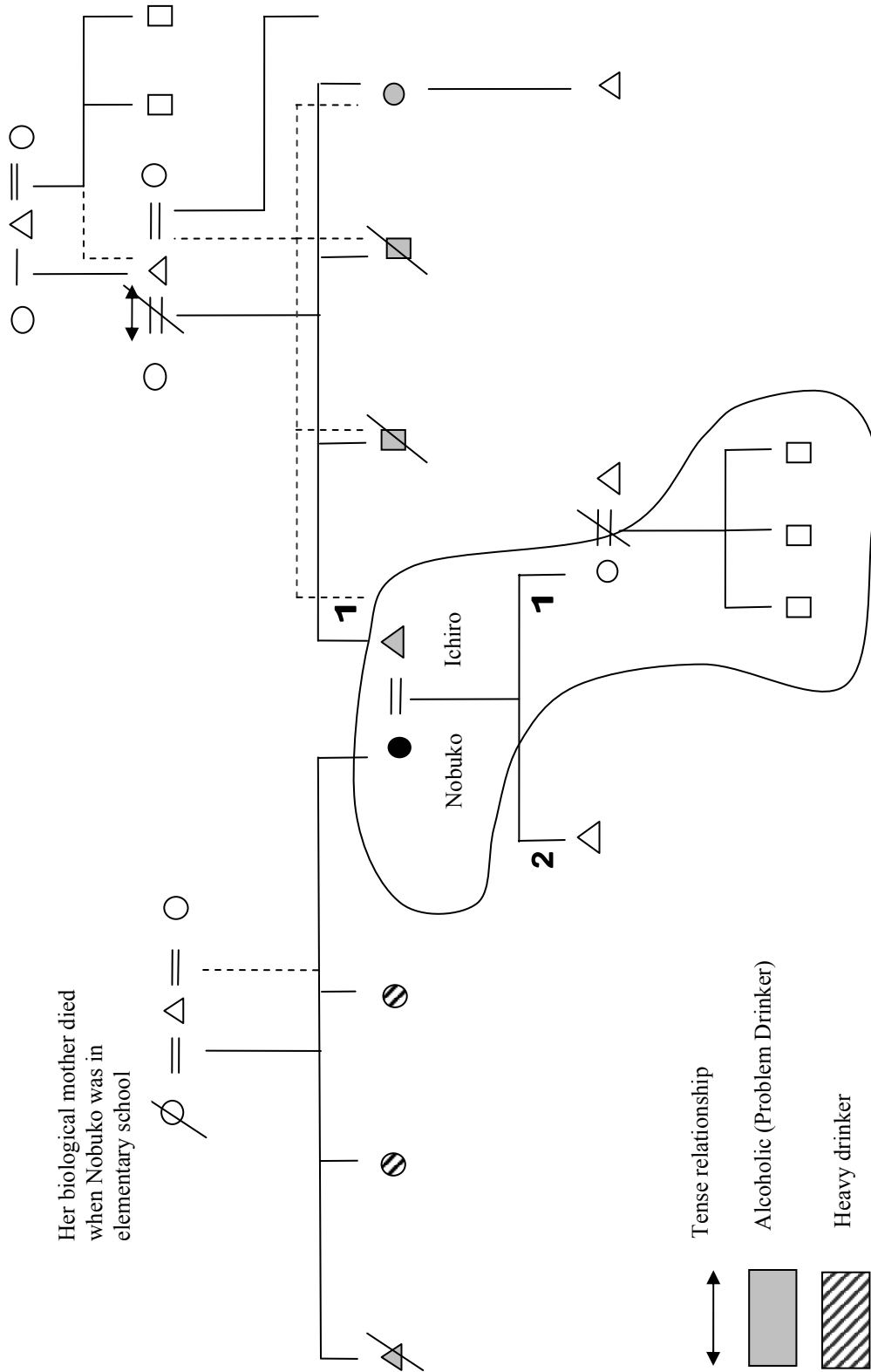

Nobuko Kikuchi

Nobuko looks like a kind woman with a big smile. Her husband Ichiro has been abstaining for approximately twenty years. During those years, she has long been involved with self-help group activities with Ichiro. I asked her about the memories of the time when Ichiro was still drinking heavily.

Family background

Both Nobuko and Ichiro have complicated family backgrounds. Nobuko lost her biological mother when she was a child and therefore was raised by her step-mother. Although her father was quite fond of drinking, she thinks it was within the acceptable range of Japanese drinking culture. Nobuko's siblings, including her sisters, are all heavy drinkers. She lost her younger brother because of cerebral hemorrhage when he was still relatively young. She recalls her brother and describes that he might have had alcohol dependence syndrome.

Ichiro's father was married twice, as well. Contrary to Nobuko's father, Ichiro's father had drinking problems. He often overturned the table when he was drunk. Ichiro's biological mother could not tolerate her husband and ran away from the house leaving the children, including Ichiro, at home. Therefore Ichiro was then raised by his step-mother. Interestingly, Ichiro's father also had a complicated family background. Ichiro's father's father had Ichiro's father with a woman before he was married. After the illegitimate son, Ichiro's father, was born, he got married with a different woman. Ichiro's father was adopted by his biological father's family and raised by his step-mother.

Nobuko has two children who are both in their thirties. Recently, however, her daughter got divorced, and is living with her parents Nobuko and Ichiro. Nobuko worried about her

daughter's divorce especially at the beginning, but she doesn't worry about it much anymore these days. She regards the current situation as far better than the donzoko [the very bottom] period she experienced when Ichiro's drinking problems were still acute.

Drinking at the beginning of their marriage

Ichiro's excessive drinking habit already existed at the beginning of their marriage.

“My marriage was arranged. We got married twenty days after I was formally introduced to my prospective partner, Ichiro. I was only twenty three years old at that time.”

-----That's a story! By the way, were you informed about his drinking habit, at all, from the go-between before the wedding?

“Yes. I was told that ‘he drinks,’ but this word didn't bother me much since I was brought up in a drinking family, too. In fact, when we got married, I didn't see him drink for a month. I therefore remember feeling the wonderfulness of married life at that time.”

-----What do you mean by ‘for a month’?

“Well, the month I married into his house was in April. You see, there are many cherry blossom viewings [≈drinking parties] held in April. Ichiro had trouble with his gastric ulcer because of his excessive drinking on such occasions at that time and therefore he had to abstain from drinking. After a month or so, when his stomach had recovered, his drinking started again.”

-----Doesn't it tell you that he was drinking too much already at that time?

“Yes. But, just to let you know: his drinking habit was not that bad at that time.”

Contrary to Nobuko's statement, that her husband's drinking habit was not so problematic at the beginning of their marriage, already at this point Nobuko indicated the existence of some alcohol related problems and continued to do so as the interview progressed.

-----How did he drink in general?

“He often drank with his friends and had fun. Occasionally he brought his friends to our house, too.”

-----Did he commonly drink outside?

“Yes, mostly.”

-----How about solo-drinking?

“There was no solo-drinking. Wait, I might be wrong. Yes, he was in fact doing *banshaku* [drinking with meal, see glossary on page 554] every day at that time. I know this since I remember preparing his relish, fish dish, everyday. I can't believe I used to do that! I was really cooking for his drinking, every single day. [Nobuko laughed].”

-----Did he behave violently toward you or have quarrels with someone because he was drunk?

“Not really.... Wait, did he used to hit me already at that time [I don’t remember]? Ichiro wasn’t really a ‘violent violent’ person. He occasionally punched me, though. He occasionally yelled at me, too. [Nobuko nodded.]”

-----“Punched you with his fist”? Isn’t that considered “violent person”?

“Yes [Nobuko laughed], you might be right. By the way, like his father, he also frequently overturned the table. As I said before, his father used to overturn the table and leave the room. It was the task of the other family members to clean up the wreckage scattered all over the floor afterwards. Just like repeating his father’s behavior.”

-----Did he throw something at you?

“No, he didn’t throw things that much.”

-----Have you ever received a call from a bar saying that they want you to pick your drunken husband up at the bar?

“No. That never happened to me.”

-----Has he ever missed work because of a hangover?

“That happened all the time. Yes, I called his workplace every time that happened. I told them that my husband cannot come to work on that day because he is sick. Yes, I was doing the so-called *shirinugui* [cleaning up the mess, see page 531] for him. [Nobuko laughed.]”

Aggravation of the husband’s drinking habit

Although Nobuko’s husband already shows these signs of problems at the beginning of the marriage, Nobuko says “he was not problematic until he became about fifty years old.” Ichiro suffered from neurosis around that time. Nobuko thinks that Ichiro’s drinking habit became bad at about this point.

“Ichiro was appointed to a responsible position of a big project as a civil engineer at a construction company. He couldn’t work well with the other team members who were in the same position as him. I believe there were four people responsible for the project. All four, including my husband, had a strong character. Three of them were university graduates. Although my husband was engaged in this business much longer than the other three, he is just a high-school graduate. I am sure he had his pride. At the same time, however, he might also have felt that he couldn’t keep up with their intelligence. He couldn’t sleep at night, suffered from insomnia, and became depressive. As time went by, not only could he not eat his meals but he also could not drink his favorite alcoholic drinks.”

-----Were you aware of his problem at that time?

“Yes. We went to see a psychiatrist at a big hospital together. There were also some people at work who sympathized with his problem. One of his colleagues advised him to take a break and

not to come to work for a while. I was very anxious about Ichiro since he said things like ‘I want to die. Someone like me is useless in this world.’ [Nobuko paused.] Since the psychiatrist advised me not to worry too much since he is commuting to work and that is a positive sign, I didn’t really worry about him killing himself or something along that line. But one day, he jumped from the roof [eighth floor] of a tall building to commit suicide. Fortunately, he landed on a vehicle and so was miraculously saved. He got a concussion and had to stay in the hospital for half a year. His strange drinking habit—drinking secretly—started around this time in the hospital. [Nobuko paused] While in the hospital, he drank alcohol during the meals, or sometimes suddenly left the hospital and drank at a bar. He started to drink in a dangerous way. I became worried. I was worried not because I thought he will commit suicide again, but because he might get involved in an accident because he was too drunk.”

-----So, it is at this time you started to regard your husband’s drinking as definitely problematic?

“Yes. [Nobuko paused] After the hospitalization, he returned to his previous workplace. Since his neurosis’ direct cause was related to his work, his bosses were very considerate. They allocated him to the Tokyo head office—he had yearned to work there for a long time—for a month, and then re-allocated him to the associated company near our house where he was allowed to do milder work. Despite the people’s consideration, he occasionally slipped out of work and drank during that time. [Nobuko paused.] One day, he left home as he was going to work, like usual, but, later, I received a call from a neighboring prefecture’s hospital [It takes at least two hours by local train from his home to that place] saying ‘Your husband got injured in an accident and we are taking care of him right now. Could you please come to the hospital, immediately?’”

-----What happened? Why was he there, so far away?

“It’s his hobby. He likes spending time riding the train without having any destination and visit places like the local shrines when he gets off. During these visits, he commonly drinks, too. He does all this without giving us any notice. I think his trip to the neighboring prefecture was part of this hobby.”

Drinking amount

-----How much did your husband drink around that time?

“The problem is that I am not exactly sure about that. From my perspective, he didn’t seem to be drinking that much. At home, he was allowed by me to drink only one and a half *gou* [≈ 0.27 liters ≈ 0.07 gallon] of sake. Even when his drinking habit was the worst, the amount of alcohol I served per day was only one can of beer and one *gou* of sake.”

-----Quantity-wise, that doesn’t sound much.

“Right. In fact, I have seldom seen him drinking a lot. He therefore often said to me that ‘I was misdiagnosed and labeled as alcohol dependence syndrome.’ He doesn’t see himself as a problem drinker at all.”

-----Well, that may be true. By the way, is he a biologically incapable drinker?

“I think he is. When he drinks, he falls asleep immediately.”

-----Hmm.

While I was thinking that Ichiro may indeed not be an alcoholic [in this context, it means ‘problematic drinker with alcohol dependence’] and therefore should change the direction of the interview to explore its relevance, Noriko added.

“[Nobuko looked as she was thinking.] I’m not sure if he is alcoholic, either. Perhaps he is [alcoholic]. I don’t know. He indeed does not drink in front of me, but, for example, he was sometimes drinking secretly when I was not around, like in the yard outside. If he happened to have the opportunity to drink, he drank as much as possible with tremendous speed. For example, one day, he said ‘I have to pee,’ and left the room. Our house is an old house where the toilet is outside the house. Usually, he keeps the door open while he pees, but on that day he was keeping the door shut. I became suspicious and so went there to check what he was actually doing in the toilet. As I expected, he was indeed drinking in there. There are more episodes like this. He hid alcoholic beverages in various places of the house: inside the plant pots, behind the books on the book shelves, etc. I couldn’t believe it when he hid it inside the sanitary container at the toilet!!”

----- [Hearing the word ‘sanitary container,’ I burst into laughter.] Excuse me. This is not supposed to be funny. [I burst out laughing again.]

“He really pisses me off! Once I really got so mad with this behavior that I ran out from the house. I came back home after all, though. Losing one’s temper always works disadvantageously. I really recommend you not to do that. [Nobuko smiled.]”

----- [I am looking at the kinship chart.] Your husband’s line seems to like hiding things, don’t they? [I smiled. I was joking.]

“[Nobuko made a serious face.] There is some truth to that. Ichiro seems to do whatever he wants to do, as long as other people are not watching it. It’s pathetic...”

Husband’s drinking problems

Since the attempted suicide, Ichiro’s drinking habit worsened. He slept at the roadside or was caught in an accident because he was heavily drunk.

“Police cars, ambulances....he was taken to the hospital via various types of cars. Sometimes, he was sent to the same hospital as the previous month and the nurse remembered us and said, ‘Oh, you guys again.’ [Nobuko sighed.] Even though I try to leave the problems to him, people are too kind and help him, calling me, the police, or the hospital... Eventually, he became used to being helped by someone else. [Nobuko made an annoyed face.] He himself was not aware that he was causing trouble. At that time, since he was involving so many other people because of his problem, I commonly thought, ‘I wish I could carry all the burdens. I wish it’s only me who feels the pain.’ I was awfully annoyed by him causing trouble to other people, especially strangers.”

Nobuko says these experiences of causing trouble to others affected the formation of the children's characters as well.

“For example, my daughter severely scolds her children when they cause problems at school, even if it was because of a trivial problem. She strongly desires her children ‘not to stick out’ and ‘not to cause trouble to others’ which is probably related to her bad experiences in her past.”

She continues talking about Ichiro's drinking problems.

“In our house, we have a mahogany chest-of-drawers which has locks on the top drawer. Well, he broke it and tried to steal money from the top drawer. He probably wanted to buy alcohol with the money. He couldn't get it after all since there was no money in there in the first place. On that day, when I was walking around our neighborhood, I saw a truck carrying a chest of drawers very similar to ours. Seeing it, I thought, ‘Oh! That chest of drawers is similar to ours.’ Well it was in fact ours. They were repairing it since he broke it.”

-----It sounds like you were the one managing the passbook [bank account]?

“Yes. There is no way I will allow him to manage the money in our house.”

-----Was there any violence around this period?

“Yes, somewhat. But, his violence is not that severe. Ichiro in general does not have a bad temper; he rarely becomes angry. Well, there were occasions when he became angry and made a

stiff face, which was scary. He hit me occasionally, too. But, you see, I attack back when he used violence. And usually, when I responded to him aggressively, he withdrew from the fight.”

----Did your physical fight ever extended to the level of kill-or-get-killed fight, where either one used a weapon such as knife or bat?

“No. Wait. There was one time when he said to me ‘I am going to kill Kazuko [their daughter] so hand me that *deba* [butcher knife]!’ when he fought with our daughter.”

One day he got injured while he was drunk and sent to the hospital, like usual. This time, however, he was sent on to the hospital that specializes in alcohol treatment. And from that occasion until now, although he lapsed several times and drank in between, he has basically been abstinent from alcohol.

The reasons for Ichiro’s drinking problems

----Hearing your stories, there seems to be more than just a drinking problem in your family. Based on what you have told me and what you have experienced, how do you understand your family situation? What do you think is the problem in your family?

“Perhaps you are right. Drinking itself may not be the biggest problem in our family. But what would it be, then? [Nobuko looked as she was thinking.]

-----Let's return to the story of your husband's drinking problems. Why do you think your husband drank so much? Besides the obvious reason that he likes to drink, please describe any other possible reasons that you can think of.

“Besides the reason that liked drinking.... As I said, I think it was because of the neurosis caused from his work. Ichiro is timid, especially when it comes to work. For example, when he gets appointed to an important position such as group leader, he gets depressed, and grumbles with a deep sigh, ‘I have to work as the group leader. How can I do this?’ He probably feels so since he is a responsible person. When we got married and I saw him doing this, I commonly thought, ‘Oh, no. He will probably not climb up the ladder very much.’ [Nobuko laughed.]”

----- [I look at the kinship chart.] Your family relations are complicated. Do you think this is related to the problem?

“Yes, I certainly think so. I think the lack of the parents' love is related to his problem. I think Ichiro regards me as his mother. Incidentally, I think I am acting the mother for him, too.”

----- You certainly took care of him.

“For that, I think my family background is related. I think I have co-dependence problem. It's like lacking the capability to not take care of him. For my marriage, too. Instead of feeling whether I like Ichiro or not, I neglected that feeling and strictly said to my self, ‘this [the situations she experienced] is what marriage should be.’”

-----Was there any mother-in-law problem which put Ichiro in a difficult position and therefore consequently led him to drink excessively?

“Yes. There were occasions when I had trouble with my mother-in-law, which made Ichiro mad and resort to violence. There were also occasions when my mother-in-law and father-in-law fought, which made Ichiro mad and resort to violence, too. [Nobuko paused] Around the time we just got married, Ichiro’s father said that he wanted to marry another woman, which all the other family members opposed. Consequently, Ichiro’s father and his new wife left the house. Because of this, I, who remained in the house, had to take care of my grandfather-in-law, who was supposed to be taken care of by Ichiro’s father and his new wife.”

-----You, as a newly wed wife, must not have been happy about this.

“[Of course not.] But since Ichiro’s sister sympathized with me, it wasn’t that bad. Ichiro’s sister listened to my grumblings, as well as, helped me take care of my grandfather-in-law. I really appreciated her help. [Noriko paused.] In this circumstance, I complained to Ichiro about my problem. And because of this, there were fights between us. He got mad and resorted to violence. Perhaps our relationship as a married couple was already unhealthy at that time. I was around twenty five or twenty six at that time.”

Husband

-----What kind of person is your husband? You mentioned that he gets on the train aimlessly or likes hiding thing etc. It seems to me that he is quite a character.

“Oh yes. He is quite a character. Every day, he reads the newspaper’s death column, first thing in the morning. And sometimes he visits the dead person’s grave, too.”

-----You mean, he visits the grave of his acquaintance?

“No. He visits the grave of people he does not know at all. He just goes there and prays and comes back. That’s it. I’m not sure it is right to say that this is his hobby. Anyway, he does this every day as part of his life.”

Consultant

-----Did you have anyone besides your sister-in-law whom you could consult about your problems?

“Unlike other people, I had people at home I could talk with about my problems. I was working at a cafe, and the master’s wife often listened to my stories. As described earlier, my sister-in-law helped me in various ways. Not only did she listen to my stories, but she also accompanied me to the hospital and sympathized with me frequently. This truly saved me. In terms of consultants, I think I was very lucky. I really think so, even now.”

Nobuko’s participation in self-help group meetings

-----You have long been going to self-help group meetings with your husband, right?

“Yes. No matter what happens, we never missed going to the self-help group. I hear stories like a man stops going to the meetings because he drank again and therefore feels shameful about

himself and can't go to the self-help group. Contrary to this, Ichiro goes to the meeting even if he slips [drinks]. He doesn't reveal that he slipped at the meeting—in fact, he can't say that he drank—but he does go to the meeting. Going there, even if he drank, is respectable, from my perspective.”

-----'You accompanying him' is respectable, from my perspective, too. Incidentally, I occasionally hear that if the wife joins her husband at the self-help group, the husband's abstinence is more likely to succeed. What do you think about this idea?

“I think it is really true. Recently, I have heard the following story. It is about a couple where the husband was abstaining. By the way, his wife doesn't go to the self-help group. According to the husband's story, his wife visited her old friend, whom she hadn't met for a long time. During her stay at her friend's house, her friend's husband served her tea. When she came back home, she sarcastically said to her husband, 'Contrary to my happy girl-friend, whose husband serves her tea, my husband is... [Nobuko sighs.]' It seems like this remark pissed him off and he started drinking again. The man had diabetes, and so was not supposed to eat sugar. But with the feeling, 'You bastard!' he went to a *gyu-don* shop and had two bowls of *gyu-don* [Beef and onion dish, cooked with soy sauce and a lot of sugar.] and then went to the confectionary store and bought various kinds of sweets.”

-----How strange he feels “You bastard!” but he abuses himself instead of somebody else, like his wife.

“Right. It’s the psychology of alcoholics. Anyway, that aside, he expressed in the self-help group meeting afterwards that he was also upset about his wife who does not attend the self-help group with him. I have also heard a story where husband and wife used to attend self-help group meetings together, but since the husband had to do *tanshinfunin* [business bachelor, see glossary on page 556], his abstinence failed. It was because the *tanshinfunin* prevented them from going to the meetings together. [Nobuko paused.] I also think that the wife going to the self-help group is not only for her husband, but also for herself. For me, going there somehow makes me feel at ease. These days, however, I start feeling tired of adjusting my life to Ichiro all the time. I start feeling, ‘I don’t want to spend my precious life being only involved with Ichiro’s abstinence activities.’ You see, I want to explore new horizons. [Nobuko smiled].”

The wives who refuse to go to the meetings

-----I agree. Attending self-help group meetings for wives is for themselves, too. But,...as you know, most women refuse to go to self-help group meetings. The reason is obvious: there is shame attached to going there. Most women, who suffer from their husband’s drinking problems, feel in this way, dealing with the problem in their self-guided way, and suffering from their anxieties. Among them, there are many who end their lives like that, too. Do you have any advice or ideas to solve this problem?

“I understand that very well. They hold feelings that they are the only one in this world who is suffering. They also try to solve the problems in their own way. Yes, I really do understand that. And because of this, they really must go to these meetings. I will just say to them ‘Just go there once. It’s for your own peace of mind.’”

-----Once they go, many things seem to become easier for many women. But it seems to me that this first step is the most difficult part. Do you have advice for these women who are reluctant to take the first step?

“Well, I have heard recently that one woman went to the public health center and consulted about her husband’s drinking problem. The staff at the health center came to rescue the situation in the middle of the night when her husband was drunk and causing problems. Through the discussion between the staff and the husband, the husband decided to go to the hospital and receive proper medical treatment afterwards. So, why don’t they go to the public healthcare center? The center is not stigmatized and therefore perhaps easier to go.”

-----Well, unfortunately, there are people who are reluctant to go even to the public health center.

“If their problem is that bad, I have no solution either. You see, wives have to take action from their side, too. It’s their life. They are supposed to be responsible for their own lives. Suffering by yourself from anxiety caused by the possibly doomed future is not good at all.”

-----“God helps those who help themselves,” right?

“Yes, that’s exactly what I am talking about.”

“God helps those who help themselves” is a Western societies’ proverb that emphasizes the importance of making effort by oneself to attain a goal. In Japanese society where human relations operate through the superior’s guessing the inferior’s feelings (*amae*) and behaving

accordingly, there is a cultural idea that inferiors should humbly and passively wait for help to be provided by the superior. Especially among women who are expected to behave even more passively than men because they are the secondary gender in addition to being Japanese. If you are the wife of a capable man, who is willing to take care of people surrounding him in every aspect of life, then playing the passive role may work well for surviving in this society; if the man is an incompetent alcoholic, however, abolishing this idea and taking action by herself to improve the situation may be a better course.

Case 15. Even if he is such a bad husband, I still want to live with him again.

Name				Age		Occupation									
Saki Yoshida				69		Used to be a part time worker at a food processing plant									
Family						Husband's Occupation									
Nuclear		<input checked="" type="checkbox"/> Extended		# of members		6		Constantly changed job (once a taxi driver)							
Family members															
Ichiro		Husband		69											
Saki		Wife		69											
Kazuo		First son													
Tsugie		First daughter				Eating disorder									
Mitsuo		Second son													
Hajime		Ichiro's father				Deceased, alcoholic									
Hatsu		Ichiro's mother				Deceased									
Total Interview Time				Wife Attending Self-help Group?				Husband Attending Self-help Group?							
1 hour 45 minutes				Yes <input checked="" type="checkbox"/> No				Yes <input checked="" type="checkbox"/> No							
Wife's KAST concerning her husband's alcohol related behavior (See Appendix 1 on Page 546)															
1	2	3	4	5	6	7	8	9	10	11	12	13	14	Total	
<input checked="" type="checkbox"/> 3.7	<input checked="" type="checkbox"/> 3.2	<input checked="" type="checkbox"/> 2.3	<input checked="" type="checkbox"/> 2.2	<input checked="" type="checkbox"/> 2.1	<input checked="" type="checkbox"/> 1.7	<input checked="" type="checkbox"/> 1.5	<input checked="" type="checkbox"/> 1.2	<input checked="" type="checkbox"/> 0.8	0.7	0.7	<input checked="" type="checkbox"/> 0.6	<input checked="" type="checkbox"/> 0.5	<input checked="" type="checkbox"/> 0.5	≈20.3	
-1.1	-1.1	-0.8	-0.7	-0.7	-0.4	-0.5	-0.2	-0.2	0	-0.1	-0.1	0	0		
?	?	?	?	?	?	?	?	?	?	<input checked="" type="checkbox"/> ?	?	?	?		
Analysis (See Analysis on Page 489)															
<input checked="" type="checkbox"/> A1	<input checked="" type="checkbox"/> A2	A3	A4	<input checked="" type="checkbox"/> A5	<input checked="" type="checkbox"/> A6	<input checked="" type="checkbox"/> A7	B1	<input checked="" type="checkbox"/> B2	<input checked="" type="checkbox"/> B3	B4	<input checked="" type="checkbox"/> B5	<input checked="" type="checkbox"/> B6	G1		
<input checked="" type="checkbox"/> C1	<input checked="" type="checkbox"/> C2	<input checked="" type="checkbox"/> C3	C4	<input checked="" type="checkbox"/> C5	<input checked="" type="checkbox"/> C6	<input checked="" type="checkbox"/> C7	D1	D2	D3	D4	<input checked="" type="checkbox"/> D5	<input checked="" type="checkbox"/> D6	D7	<input checked="" type="checkbox"/> D8	
E1	<input checked="" type="checkbox"/> E2	E3	<input checked="" type="checkbox"/> E4				<input checked="" type="checkbox"/> F1			<input checked="" type="checkbox"/> H1	<input checked="" type="checkbox"/> H2	<input checked="" type="checkbox"/> H3	<input checked="" type="checkbox"/> H4	<input checked="" type="checkbox"/> H5	<input checked="" type="checkbox"/> H6
Types of Problems (See Analysis on Page 489)															
<input checked="" type="checkbox"/> Verbal Abuse			<input checked="" type="checkbox"/> Physical Abuse			<input checked="" type="checkbox"/> Financial			<input checked="" type="checkbox"/> Psychological			<input checked="" type="checkbox"/> Shirinugui		<input checked="" type="checkbox"/> Child-Related	
Note															
Marital Status: married, but currently living separately															

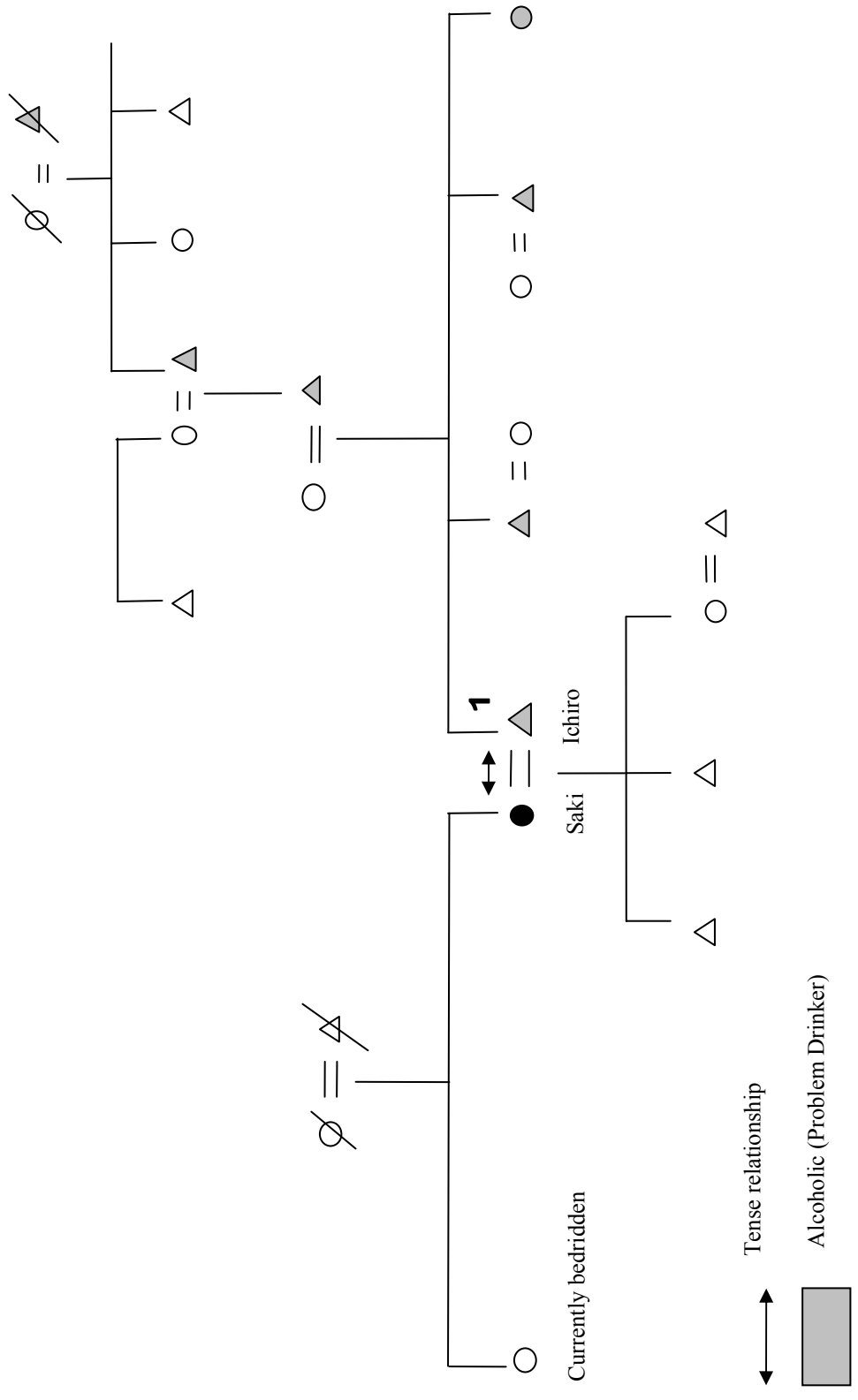

Saki Yoshida

Saki is more reserved than the average Japanese woman. She covers her mouth and her nose with a handkerchief while talking. Sometimes she traces the pattern of the table cloth's lace with her finger while speaking. She stammers; releases words poetically. Since this was her style of speaking, I articulated her feelings and asked if what I grasped was what she meant to say throughout the interview.

-----May I ask for your age?

“Aa...age? Um ah. [Saki looked down.]”

-----There is no need to be shy. [I smiled.] If you don't want to tell me, however, that's all right, too.

“I am too old. [Saki looked down.]

-----[Shall I proceed to the next question?]

“Please write down that I am in the late sixties. [Saki smiled]”

Saki is probably not speaking like this because she is reluctant to talk with me. This is her style; she has been communicating like this throughout her long life.

The Present life

Currently, Saki is living separated from her husband. She started this lonely life when she was in her late sixties. Saki told me that she never told the stories she told me in this interview to anybody else, not even to her good friends or her close relatives. She says her daughter understands her problem the most. Even the daughter, however, does not know Saki's real secret—that even now, she still wants to live together with her husband.

Ichiro's drinking habit at the time of the marriage

-----Were you aware of your husband's drinking at the beginning period of your marriage?

“No. Since I knew little about the world, I didn't notice anything by looking at the way he drank.”

-----Did you grow up in a drinking environment?

“[No, I didn't.] My original family was not total non-drinkers, but they drank so so. For example, we drank some on special occasion such as New Year's Day. I was insensitive to such things [≈alcohol related problems]. I couldn't therefore articulate the problems as 'problems.'”

-----Are you saying that “you weren't brought up in a drinking family, so you weren't aware of your husband drinking problem at that time”?

“[Saki nodded.] Even if I witnessed bad drinkers with horrible drinking habits—being drunk and having quarrels with other people—I commonly thought they were 'normal [non-problematic].’

[Saki paused and talked with regrettable voice.] If only I was aware of the problem at that time....”

I could not guess what would be following these words: “I wouldn’t have married him”? or “I would not have had to go through so much torture”? In any event, her regret was obvious.

-----Tell me about the first time you noticed your husband’s drinking problem?

“It was when my daughter was still two or three years old, so I think he was probably about twenty two or three years old at that time. One evening, somebody carried him home. He was severely beaten. It seemed like after work, he drank at a bar, got drunk, picked a quarrel with somebody at that bar, and became like that. [Saki paused.] Thinking about it, there is another story, too. He got drunk and someone brought him home, like usual. This was also when my daughter was still little. Anyway, I remember my daughter approached the man who brought Ichiro home and said to him, ‘Please, Mr.! Stay at our house!’ ‘Mr.! Please stay over night at our house!’ She asked desperately. Poor girl. Already at that time when she was a child, she was scared of her father. Yes, already at that time....he had the problem....”

In those days, she believed that his drinking problem would disappear as time went by. However, contrary to that optimistic expectation, his drinking habit only became worse. He started drinking on credit and increased his debt. He also stood as the guarantee of other people’s debt and lost a significant portion of his property.

Husband's drinking habit

-----Tell me about when you started to realize that your husband “was definitely deviant” or “clearly has a drinking problem.”

“It was around the time when we moved out from the apartment complex and started living in a house with his parents. I believe it was when he was in his thirties [37 or 38 years old]. Since we were living with his parents, his siblings' families often visited on the weekends. Every time when these people gathered in our house, they had boisterous merrymaking. Usually, at the beginning of the gatherings, things were calm and even harmonious. But, eventually, as time progressed, people started to have disputes with one another and somebody always ended up crying because of the quarrels. Ichiro's parents yelled at people: ‘Shut up!’ or ‘Cut it off!’ and my sister-in-law started sobbing.... Our life has been a repetition of this pattern all the time.”

-----Is Ichiro's family a drinking family?

“Yes. Everybody drinks in Ichiro's family. His father and sister, too. Even though his sister is a woman, she is a drinker. Usually, women don't drink, but that is not the case with Ichiro's sister [By the way, Saki doesn't drink either.] When I got married, I was quite surprised by her drinking habit.

-----Do Ichiro's siblings and his father drink to the extent that it bothers their spouses?

“Yes. Oh, wait. The middle brother doesn’t have much of a drinking problem. But for others, their spouses are all troubled by the drinking problems. Always, they drink, get into a fight, and somebody ends up crying....As I said, this is their pattern all the time.”

-----What is the reason for the quarrels in general?

“Oh, it’s trivial matters such as ‘I want to drink more’ or ‘Bring more drinks’ etc.”

-----Do you have any repetitive quarrel topic which comes up every time when there is a fight?

“No. I don’t think there is such a thing. But these people always become angry for stupid things and complaint like, ‘I want to drink more!’ ‘Bring me more sake!’ ‘You are hiding drinks because you are reluctant to serve it to me!’”

According to Saki, the quarrels involve her husband all the time; it always happens between Ichiro and his parents, brother or sister.

Considering the fact that her obvious awareness of her husband’s drinking problem was when he was in his late thirties, she has been troubled by Ichiro’s drinking for a minimum of twenty five years. Although he was diagnosed with liver disorder and alcohol dependence syndrome, he has not and is not willing to go through proper treatment for these alcohol related diseases. According to Saki, he doesn’t show any interest in abstaining at all.

“Once he told me that a doctor gave him permission to drink since his problem was recovered. So I guess it’s okay for him to drink now.”

-----A doctor said that? No way!

“No, I am not kidding. Ichiro really told me, ‘The doctor said to me that my disease got cured so I can drink again.’”

It was obvious to me that a doctor would not say anything like that to patients diagnosed with alcohol dependence syndrome. Alas! If she only was more knowledgeable of the nature of alcoholism, she would not have been fooled by such a downright lie!

Husband’s violence

-----Did your husband resort to violence when he drank?

“No, not really.”

-----How about verbal violence, such as making you listen to his tedious complaints?

“There were no tedious complaints, but he did yell violently at me like ‘You bastard!’ or ‘Shut up!’ My husband can’t think deeply. That’s in fact the reason for his drinking; he drinks because he doesn’t want to think. In other words, even if he wanted to say something constructively, he wouldn’t do it because he just can’t.”

-----Did he threaten you, for instance by banging on the tables or the walls?

“A little bit. He often threw things. [Saki paused] And sometimes he pushed my shoulder...and then injury.”

-----You were injured because he pushed your shoulders?

“[Saki nodded] At night, he comes back home drunk....and I am scared. So, I lock my bedroom door. However, he tries to tear off the lock and tries to come into my room forcefully.”

-----Your bedroom is separate from your husband’s bedroom?

“[Saki nodded.] I am sleeping alone in my bedroom and Ichiro is sleeping in the room where his parents used to sleep.”

-----Do you consider this situation as *kateinai-rikon* [divorce within the household, see glossary on page 556]?

“[Saki nodded.] But, when he is drunk, he tries to come into the room *forcefully*. He literally broke the door once, too.”

-----That surely sounds forceful.

“It’s dreadful. And it’s disgusting.” [Saki made a wretched face]

----- [Disgusting???

“He’s a man.....so it’s disgusting.”

----- [???

“He’s a man. He *forcefully* opens the door and comes into the room violently at night...”

----- [!!!] Are you saying that he tried to have sex with you forcefully?

“[Saki nods several times with a wretched face.] It’s disgusting.... Late at night, he comes back home and shouts to open the bedroom’s door where I am inside. I usually keep it locked. If I don’t open it, he forcefully tries to open the door. Since he is a man, it’s disgusting.”

Work at a Food Processing Factory

According to Saki, Ichiro drank outside all the time and therefore has not provided any living expenses to the family. Because of this, it had been Saki who had been providing the income for the family. From before her marriage up until a few years ago, Saki has long been working at a food processing factory as a part time worker. Ichiro was an abuser in three ways: a physical, verbal, and financial abuser.

“Since I’m not smart, there wasn’t much that I could do to earn money. Even though I am so stupid and not good at doing anything, one thing I am good at is to do what I can do, like the work I had, patiently and for a long time.”

Husband changes his character when drunk

----How does your husband drink in general?

“My husband is really a good person as long as he doesn’t drink. But once he drinks, even a little bit, he can’t stop and will keep on drinking until all the alcohol bottles in the house are empty. No matter how much or until when—one *shou* [=1.80 liter =0.48 US gallon], two *shou*...one o’clock in the morning, or two o’clock in the morning—he will drink until the last drop of alcohol has disappeared from the entire house. He drinks every day. On his off-days, he starts drinking in the morning. When drunk, his character changes. His voice becomes higher... To me, he looks like he wants to pick a quarrel with someone. His drinking habit is not pleasant to see at all.”

----What is the general reason for him getting into a fight? With whom does he fight?

“There is no such thing as ‘general reason.’ [Saki paused.] For example, let’s say Ichiro and I go out to eat. In general, we concentrate on the food, like this. [Saki pretended that there is a dish in front of her on the table and pretends that she is eating like an ordinary person.] But this is not the case for my husband. When he starts drinking, he is not concentrating on the food at all. First of all, his eyes change. And his voice or the way he talks starts to become noisy. It is clear to me that he wants to have a fight with someone. He sits like this [Saki behaved like an insolent man sitting in a restaurant seat with one elbow hanging on the back of the chair.] and starts checking

people restlessly at the entrance area or the counter of the restaurant. He is looking for ‘people of the same kind.’ And when he finds one, he moves his seat and starts talking with that person.

How can I say... It’s like picking a fight by approaching and starting to talk with the person of the same kind.”

-----Isn’t it disturbing for you when he starts wandering around looking for a fight?

“Oh, I don’t like it [=eating outside with him] at all. [Saki made a wretched face.] I hate eating with him so much. I might just as well eat alone if I have to eat with my heart in my mouth like that all the time.”

Husband

-----By the way, what do you mean by saying “the people of the same kind”?

“Well, how could I say...[Saki seemed to have difficulties answering my question.]

-----Are you talking about people like *yakuza* [Japanese mafia]?”

“Yes. I think he regards himself as a boss of *yakuza*. When he encounters people of that type, he approaches them voluntarily and tries to be friends with them. He also boastful and pretends to know many things in front of them, too. Sometimes, people tell me that my husband has an ‘*ii-konjou* [=good/brave gut].’ But, from my perspective, ... [She made a wretched face and shook her head.] One day, he was wearing loud color clothes with black tattoo-like accessories on his fingers and ears. [Saki made a wretched face.]”

In general, the type of people Saki describes is called “*chinpira* [punk, those who fail to become members of a *yakuza* group]” not “yakuza” in Japan. [Contemporary *yakuza* members no longer appear like what Saki described and are hard for ordinary people to distinguish from white-collar workers.] Incidentally, according to the person who introduced Saki to me, Ichiro is not a *yakuza*-like person but rather an ordinary craftsman-like looking person. The person also told me, however, that Ichiro does speak with a high pitched, loud voice when excited, which agreed with Saki’s description.

-----What does your husband do for a living?

“Work? He has changed his occupation so many times. I don’t know what is considered his ‘real’ job. He quits all the time so easily. It is considered good if it lasts for more than three years. Every time, he gets fired because he drinks and skips work the next day.”

According to Saki, Ichiro has worked as a construction worker, taxi driver, and the like.

The reasons for husband's excessive drinking

-----Why do you think your husband drinks so much?

“It is in his blood. He is from a family that drinks. I can’t think of anything else. He liked alcohol since he was born, so he started to drink when he was still young, and therefore became what he is now.”

-----How about his work environment? Do you think his work environment necessitates him to drink?

“He does drinking with his workmates. What? *Settai* [reception with customers]? No way! He doesn’t do that kind of fancy stuff. [Saki laughed.]”

-----Could you think of any other reason for his drinking?

“My husband cannot live without interacting noisily with people. Somebody has to be with him all the time. It doesn’t matter whether the accompanying people are his friends or not. He just needs somebody—humans—to be with him.”

-----Is he the so-called the ‘*sabishigariya* [a person who cannot stand being alone, see glossary on page 556.]’?

“Yes, yes he is very *sabishigariya*. [Saki nodded repeatedly.]”

-----By the way, did you have problems with your mother-in-law?

“I wouldn’t say I was completely free from that problem, but compared to other wives around me, my mother-in-law and father-in-law were much better than theirs. They didn’t provide any household-expenses to our family, though. In addition, my father-in-law was quite a heavy drinker, too.”

From this remark, I deduced that the probability of the stress induced from the bad relationship between bride and mother-in-law being the cause of Ichiro's drinking is low in this case.

Mother-and-child capsule

-----Sometimes when there is an alcoholic in the family, the mother tends to complain about the father to her children, which creates an abnormally strong tie between the mother and the children compared to the hostile relationships between them and the father. Do you think such a situation applies to your family?

“Oh, yes. Oh, yes. [Saki nodded repeatedly.] Since the children were little, Ichiro seldom joined the family activities such as going to the swimming pool or to the zoo. It was always only the children and me going there. Ichiro almost never joined us or spent quality time with the family. [Saki paused] I also complained a lot about my husband to my children. Now, the children rarely talk about their father. My oldest son regards his father as non-existent; the father died a long time ago. He says something like, 'Dad? Who's that? I don't think such a person exists in this house.' My daughter, on the other hand, worries about him and once in a while asks me, 'What is dad doing? Have you heard from him recently?'"

Even if he is such a bad husband, I still want to live with him again.

-----Could you tell me what kind of public services or any kind of help you want or wanted with this problem?

“I confess. Even now.... [Saki stuttered] You see...living alone is a very lonely life. There is nobody to talk with. Even if he is such a horrible person, I still want to...[Saki stuttered] If I say

such a thing to my daughter, she will scold me saying ‘Stop saying such a thing!’ But...I can’t help it.”

-----Are you saying that you want to live with your husband again?

“[Saki nodded.] Probably my children will not understand, but you see [Saki stuttered]... when you become old, many things, such as your body, don’t work as they used to. You become anxious about many things when you become weak. But, you see,... he is a horrible person who will drink and become violent if we get together again. [Saki paused.] But, if we are together, he could help me do things that I can’t do by myself. [Saki paused.] At night, especially these days when the weather is becoming cold, anxiety haunts my lonely mind. I say to myself in the bed: ‘Am I doing the right thing? Am I going to stay like this until the end of my life?’”

At this moment, I was able to imagine this thin and old [she looks older than her 69 years] Saki suffering from mental agony in her bed alone.

Good parts of husband

Considering Saki’s repeated supportive remarks about her husband, such as ‘He is the person with whom I gave birth after all.’ or ‘He is sometimes very kind.’ in the interview, it appears to me that Saki does not “totally” dislike her husband. For example, regarding her husband’s kindness, she describes as follows.

“Sometimes he calls me. He asks ‘What are you doing?’ and says things like, ‘I just wanted to hear your voice.’ When I told him about the cell-phone which I was thinking to buy, he offered to

buy it for me even though he is on welfare. Saying that I can't receive things from someone who doesn't have money,' I declined his offer.”

According to Saki, Ichiro had the tendency to buy things for other people despite himself not having money and has a hard time because of it afterwards. This habit has long been a ‘troublesome kindness’ in Saki’s eyes. Saki continued.

“During our telephone conversation, he describes how lonely he is and asks me how long I am going to live at the current apartment. [Saki hasn’t told her apartment’s address to her husband] We are both calm when we are conversing. Of course, I always pay attention to what I say not to trigger his temper, though,”

-----He seems to be a kind person. Excuse me for talking about negative aspects of your husband all the time. If I ask you to tell me about his good parts, what could you tell me?

“My husband is easily moved to tears. One day, before we started to live separately, we happened to meet each other at the roadside. When he saw me, he began crying and shedding big tears. I didn’t do anything, really. He simply became sentimental and couldn’t hold his tears. [Saki smiled and looked like she was remembering this incident. She started speaking again.]

Generally, when a wife like me who lives separately from her husband changes her apartment, her husband frantically looks for her new address and harasses her by banging on the apartment’s door, yelling loudly at that place, and the like. My husband, however, doesn’t do such things. He told me, ‘I can find you if I really want to, but I don’t want to do that kind of thing.’”

-----Hmm. Well, it seems like there is a huge gap between the time when he is gentle [=sober] and violent [= drunk].

“Yes, [Saki nodded deeply.]”

Saki expressed that she herself is often confused about which one is the real Ichiro: the one when he is gentle and sober or the one when he is drunk and violent.

-----By the way, do you think everything will be fine ‘if he only doesn’t drink alcohol’?

“[With a bitter face, Saki nodded.] I think things would be all right if he didn’t drink, but he drinks all the time...so what can I do? [Saki paused.] A few weeks ago, I happened to see him at the neighboring town’s mall. He was looking at clothes at the store...I noticed immediately that he was drunk at that time.”

Worrying about the problem alone

-----By the way, do you have anyone with whom you could talk about this feeling?

“No. There is no one.”

-----Who is the person who understands this problem the most?

“It’s my daughter. But I cannot say such a thing to my daughter.”

Self-help group

Neither Saki nor Ichiro go to self-help group meetings for alcoholism. In the past, their family physician had once taken the two and went to the meeting.

“I was still working at that time and so I couldn’t spare the time to go there regularly.”

Saki is hoping that, if possible, she wants to live together with her husband again. Yet, every day as she grows older, the increasing anxiety and weakening spirit swings the decision, especially when she hears from her husband who is kind because he is sober at that moment.

-----You have a point here. People’s feelings aren’t so clear-cut: you can’t just not like him anymore just because you broke up with him. By the way, if you can’t throw away the wish to live with him again, why don’t you start going to a self-help group and start learning more about the nature of alcoholism? I am sure you will receive emotional support as well as information of do’s and don’ts for an alcoholic’s wife. Just in case, for your information, I want you to know that there is this option.

I gave her the information for the time and location of the self-help groups around her home and told her to contact the organizer of the group casually. Saki nodded lightly and replied, ‘Thank you.’ She did not seem to be enthusiastic about going to the meeting.

MEMO

Some days after the interview, I happened to talk with the person who introduced Saki to me for the interview. According to the introducer, Saki's husband is currently struggling to lead a normal life. He is considering to enter the institution for alcoholics located in the neighboring prefecture which supports the alcoholics' recovery on a twenty four hour basis as well as provides various kinds of training for them to become economically self-sufficient. The problem for Ichiro is that he cannot afford the enrollment fee with only the welfare money. As an alternative option, he is thinking to become hospitalized at a hospital that specializes in alcoholism treatment.

----Hmm. So do you think he can't live anymore and is finally in the stage of *donzoko*? [The very bottom of life, see glossary on page 555. For many alcoholics, experiencing *donzoko* has the potential of recovering afterwards]

The introducer made a troubled face and replied:

“Well, unfortunately that is not the case. To me, he looks like he can keep on drinking for a little longer. [He hasn't reached the real *donzoko* yet.]”

Case 16. Today is the third week since he entered hospital

Name						Age		Occupation						
Natsuko Nemoto						43		Part time office clerk at a publishing company						
Family						Husband's Occupation								
<input checked="" type="checkbox"/> Nuclear		<input checked="" type="checkbox"/> Extended		# of members		4		Transportation company (Currently unemployed)						
Family members														
Ichiro		Husband		47		Diagnosed with alcohol dependence syndrome (had hallucinations). Alcohol related incident (police involved)								
Natsuko		Wife		43										
Kazuo		First son		20										
Tsugio		Second son												
Total Interview Time				Wife Attending Self-help Group?				Husband Attending Self-help Group?						
2 hour 45 minutes				<input checked="" type="checkbox"/> Yes No				Probably yes						
Wife's KAST concerning her husband's alcohol related behavior (See Appendix 1 on Page 546)														
1	2	3	4	5	6	7	8	9	10	11	12	13	14	Total
<input checked="" type="checkbox"/> 3.7	3.2	<input checked="" type="checkbox"/> 2.3	<input checked="" type="checkbox"/> 2.2	<input checked="" type="checkbox"/> 2.1	<input checked="" type="checkbox"/> 1.7	<input checked="" type="checkbox"/> 1.5	<input checked="" type="checkbox"/> 1.2	<input checked="" type="checkbox"/> 0.8	0.7	<input checked="" type="checkbox"/> 0.7	<input checked="" type="checkbox"/> 0.6	<input checked="" type="checkbox"/> 0.5	<input checked="" type="checkbox"/> 0.5	≈17.6
-1.1	-1.1	-0.8	-0.7	-0.7	-0.4	-0.5	-0.2	-0.2	0	-0.1	-0.1	0	0	
?	<input checked="" type="checkbox"/> ?	?	?	?	?	?	?	?	?	?	?	?	?	
Analysis (See Analysis on Page 489)														
<input checked="" type="checkbox"/> A1	<input checked="" type="checkbox"/> A2	A3	<input checked="" type="checkbox"/> A4	<input checked="" type="checkbox"/> A5	<input checked="" type="checkbox"/> A6	<input checked="" type="checkbox"/> A7	B1	B2	<input checked="" type="checkbox"/> B3	<input checked="" type="checkbox"/> B4	<input checked="" type="checkbox"/> B5	B6	G1	
<input checked="" type="checkbox"/> C1	<input checked="" type="checkbox"/> C2	C3	<input checked="" type="checkbox"/> C4	<input checked="" type="checkbox"/> C5	<input checked="" type="checkbox"/> C6	<input checked="" type="checkbox"/> C7	D1	D2	<input checked="" type="checkbox"/> D3	<input checked="" type="checkbox"/> D4	<input checked="" type="checkbox"/> D5	<input checked="" type="checkbox"/> D6	D7	D8
E1	<input checked="" type="checkbox"/> E2	E3	<input checked="" type="checkbox"/> E4				<input checked="" type="checkbox"/> F1		<input checked="" type="checkbox"/> H1	H2	<input checked="" type="checkbox"/> H3	<input checked="" type="checkbox"/> H4	<input checked="" type="checkbox"/> H5	8H6
Types of Problems (See Analysis on Page 489)														
<input checked="" type="checkbox"/> Verbal Abuse		Physical Abuse		<input checked="" type="checkbox"/> Financial		<input checked="" type="checkbox"/> Psychological		<input checked="" type="checkbox"/> Shirinugui		Child-Related				
Note														

Natsuko Nemoto

Natsuko appeared to me as a pleasant person. Based on her request, the interview took place at her house. When I entered the house, I felt the housewife's vigor immediately. The room was well arranged with Christmas decorations, flowers, and designer brand chinaware. In the living room, family photographs were carefully arranged on the shelves and on the walls. When I saw her husband on the family photo taken at a studio I asked:

-----Is this your husband? Hmm [I examined]. He doesn't look like a serious alcoholic at all. [I already knew at this point that Ichiro's alcoholism was so serious that he had even seen hallucinations.]

Then she replied:

“Yes. But, on this occasion, too, he was drinking and the picture was taken when he was drunk.”

Natsuko's husband is currently hospitalized at a hospital that specializes in alcohol treatment. Three weeks ago, Ichiro started to experience hallucinations. Natsuko consulted a physician who in turn advised her to consult another doctor who specializes in this kind of problem. For some time, Ichiro's drinking problem has been pointed out by people surrounding him such as his relatives or workmates. Through the company's medical checkups, his alcoholic liver disorder was found by the physician, too. It seems however that he has never been clearly diagnosed with “alcohol dependence syndrome” and never

received proper treatment in the past. This hospitalization is therefore his first experience of receiving specialized medical treatment for alcohol dependence syndrome.

How Natsuko met Ichiro

-----How did you meet Ichiro and get married?

“I used to go to a beauty parlor which I was fond of. The manager there suggested that I meet one of his important male acquaintances who was still single at that time. Later, I found out that the man the manager was talking about was the brother of my high school tennis club’s *senpai* [≈senior. Generally speaking, *senpai* are the old member of the group and are socially expected to mentor their juniors who are called *kohai*.]! I thought, ‘What a small world!’ During my high school period, I belonged to the tennis club and Reiko [Ichiro’s elder sister] was a *senpai* who took care of me a lot. It seems like Reiko herself was also considering me a good candidate for her younger brother, too.”

-----What a destiny! So you did *omiai* [a type of meeting where a person is introduced to a prospective marriage partner by the go-between] kind of thing afterwards?

“Yes. One day, Ichiro, Reiko, and I met at a coffee shop. Reiko was the go-between. This was like the *omiai* for us.”

-----And after this, you became acquainted and eventually got married, correct? [Natsuko nodded.]

-----How long did you go out together and when did you get married?

“I got married when I was 22 years old. I went about with him for one year and six months. Since he was living far away in Osaka [several hours by bullet train], we had a long-distant relationship for most of the time, though.”

-----Was he living in Osaka when you first met him, too?

“Yes. He came all the way from Osaka to meet me here in Tohoku. After we started our relationship, we met each other every month.”

-----Between here and Osaka? That’s quite a distance! It’s expensive, too.

“Yes. He came by bullet train or airplane to see me. His father was paying for the tickets, though.”

-----Why his father? Was Ichiro so late getting married that his father worried about him remaining a bachelor?

“He was 28 years old at that time.”

-----Hmm. It's nice that he came all the way from Osaka using the bullet train and airplane to see you, though.

“Yes. But, my grandfather [Natsuko's father's father] opposed our relations. He suggested to my parents not to let me marry a man who might take me away from my family to a distant place like Osaka. I was therefore told by my family that I can marry him *only if* he is going to live here in Tohoku. So, Ichiro asked his company to transfer him to the company's Tohoku branch which they granted. It was hard, but we made it.”

-----You're lucky! Considering how you met him, his efforts to visit you all the way from Osaka, and how he handled the problem of working in Osaka, I bet you thought your married life would be happy under the care of your husband, didn't you?

“Yes. I thought exactly that and *ended up* marrying him [tone of regret].” [Natsuko and I both laughed.]

Husband's drinking habit before marrying

-----Was your husband a “cheerful drinker” or a “gloomy drinker”?

“He is certainly *not* a cheerful drinker. He does become talkative when he drinks, though.”

-----Is he a reticent person?

“He is not a really reticent person, but he is rather towards that direction, yes.”

-----Is he a social person, good at mingling with people?

“No, no. He isn’t good at that at all. [Natsuko laughed.]”

-----What was his drinking habit before you were married?

“Well, before the wedding, we often had dates. Since both of us were working outside, we commonly met at some place after work. Most of the time, we met at places that served alcohol. They weren’t just cafes; they were cafe-like places that also served alcoholic drinks. Because of my work, I often came late. On such occasions, he often already had a couple of drinks. At that time, he took me to various bars. Since I was brought up in a non-drinking family, going to such places was a very new experience. I felt ‘Wow, people who drink come to these kinds of places!’ or ‘I have never been to such a place!’ I was often very excited.”

-----So, going to bars with him didn’t make you think that he has problems but you rather took it as an amusing activity?

“Yes. I never perceived it as problematic at all.”

-----Around this time, were there any occasions which made you feel that he might have a drinking problem? If yes, please tell me about it.

“This is something that I feel now. It was about the time when we were engaged and the wedding date approached. Like usual, we ate and drank outside and then visited Ichiro’s house where his parents lived, too. When I met Ichiro’s parents, his mother asked me anxiously: ‘Was Ichiro behaving properly after he drank? Was he maintaining normal character?’ Thinking about it now, she may have said this because he isn’t well-mannered when he drinks in general. Meaning, he may have usually lost his control when he got drunk. I think that’s the reason she asked me such questions.”

-----Does “This is what I feel now” mean that you didn’t suspect such a problem to exist at that time?

“Right. I wasn’t aware of any problem at all. At that time, when she asked, I simply replied ‘No. He didn’t have any problem.’ and that was it.”

Probability of drinking problems before the wedding

-----Perhaps he already had alcohol problems before the wedding.

“Right, two months after we got married, he was hospitalized with a duodenal ulcer [A sharp pain in the upper abdomen area when the stomach is empty, 3-4 hours after meals or at night when sleeping. The symptoms also include heartburn and bloody feces. The cause

can be excessive alcohol consumption, but it can also be caused by non-alcohol related problems such as stress or irregular meals.] Two thirds of his stomach was removed by the operation. He didn't drink while in the hospital, but he started drinking again when he came home. One such day after his surgery, there was a drinking party for the new employees' at his workplace. He got drunk and so a young female employee brought him back to our house. When I saw him being in her care, I was very ashamed of him. [Natsuko made a troubled face.]”

Husband's family

-----By the way, was your husband brought up in a drinking family? For instance, is your father-in-law a drinker?

“Yes, he is a drinker.”

-----Does his drinking behavior cause trouble to his wife?

“Not really, I think. In this house, everybody including my father-in-law, mother-in-law, and sister-in-law, grandma-in-law, and my husband drink A LOT. They are people who drink and become loud, too. When they drink, they become extremely talkative, like everyone carrying the attitude of ‘You listen while I talk!’ Everyone's voice becomes louder and louder.... When it comes to my father-in-law and Ichiro, they occasionally even pound their fist on the table and try to make their point. I don't know why, but both of them like making a fist in their hand. [Natsuko made a fist in her hand and nodded several times.]

From their perspective, these are not considered fights. However, from my perspective....I often think ‘Why do they have to behave in such a wild manner and make such a big noise?’... Anyway, but, contrary to Ichiro, my father-in-law has his own rules that he lives by. He drinks a certain amount [of course every day], and when it turns 8:30 p.m., he says ‘Well it’s time for me to go to bed.’ and goes to his room. After this, the other people start drinking. This is our routine, our pattern of life. There is this pattern in his house.”

-----When Ichiro or your father-in-law starts talking with a wild attitude, what do they argue about?

“Hmm... [Natsuko tried to recall.] I don’t remember.”

-----Are there violence problems in this house such as somebody overturning the table, throwing something at somebody, kicking or hitting furniture and tables, or using lethal weapons such as a wooden sword, bat, or kitchen knife?

“No, those kinds of problems do not happen at all.”

Alcohol consumption

-----Who drinks the most in this family?

“I think it is Ichiro.”

-----How much does he drink when he is in the mood?

“When he wanted to, he was able to drink at least two bottles³³ of whiskey per day. He was like that right before the hospitalization.”

-----By the way, do you drink, too?

“Yes, I do.”

-----How much do you drink?

“If it is a beer, I drink about 2-3 medium size glasses per time.”

-----Is that your maximum amount or regular amount?

“That is my average amount.”

According to Natsuko, she is considered the one who drank the least in this family. She describes herself to be the least problematic drinker, too.

³³ I did not ask about the size of the bottle.

“I am often the only one not being drunk. So, when we drink and it becomes late at night, people make their excuse, ‘Well please take care of the rest.’ and leave to their bed. I often think, ‘Hey, hey?! Why only me? That’s not fair!’”

Beginning of married life

-----I would like to ask you about the time after you got married until the problem became severe. First of all, tell me about your first experience of a so-called alcohol-related incident caused by your husband?

“Well, since there are a lot, I don’t know which one to talk about... Hmm, you are asking for an episode when I was still young... [I nodded and Natsuko seemed to be thinking.] Well....about 3-4 years after our wedding, we started living in Osaka again. One day in Osaka, around 11 o’clock at night, he was caught drunk driving by the police. Because of this, his driver’s license was taken away.”

-----How did you feel when this happened?

“I thought, ‘Alas! He is a man who can’t distinguish good from bad when he is drunk.’”

-----Does your husband drink more outside or at home?

“At home, definitely. He drank only about three times per month outside. At home, he drank almost every day.”

-----Have you experienced a situation where a bar's *Mama* [female manager of a bar, see glossary on page 556] calls you to pick up your husband at a bar?

"No, not really."

-----How about him skipping work because of his hangover?

"I am sure we had that at that time. But I don't remember."

-----Any violence at that time?

"No, that didn't happen at all."

Natsuko's biggest problem

-----What is the biggest alcohol-related problem in your life?

"I am often troubled by the gap in his character when he is sober from when he is drunk. He is inconsistent and I don't know what to believe or follow."

-----Could you tell me more about that?

“Well for example, my son Kazuo plays soccer. Since his elementary school time, he has been a member of the soccer club, a mandatory school activity at junior high school, high school etc. Ichiro liked going to see him play. But, it was a little problematic for Kazuo. My husband not only went to see the games, but also the daily practice. Kazuo disliked that and so asked my husband not to come. My husband often agreed and said, ‘Okay. I will not come anymore.’ But that was always momentary. After a few days, he always started to go to Kazuo’s soccer again. One day, Kazuo strongly complained to his father and asked him not to come to his soccer anymore. My husband got angry and replied, ‘Fine! I am not going to your games anymore, ever! But this also means that we, as parents, are not going to support you or give you advice, either!’ This was a problem for me. I wanted to go and watch my son play in the competition. As his mother I wanted to help his team on such occasions, too. So since my husband blustered out, I always had to ask him for permission to go to see Kazuo’s game. When he is drunk and is in a good mood, he said, ‘Yes.’ But when I am about to leave the house for a game, if he is sober, he tells me not to go. In such a situation, I ask him, ‘Why? Yesterday you said I could go. How come you don’t follow your own word?’ But it is of no use. He sticks to the principle that I am not allowed to go and there is no room for discussion.”

Natsuko continued.

“Also, when our children were still small, he frequently canceled our family plans to go out to have some fun because he had a hangover. I often thought ‘Why? We planned this ahead

of time. We are now about to go but he is trying to cancel the whole thing because he has a hangover. Why are we always like this?' I was not happy at all when this happened."

Drinking problems that became severe ten years ago

According to Natsuko, her husband's drinking problem became severe ten years ago when they started living in Osaka again.

-----Did you receive any advice or comment from your husband's boss or his colleagues around this time?

"Yes, about 15 years ago, I had a chance to meet my husband's boss. At that time, his boss told me, 'Mrs. Nemoto, you better do something about his drinking.' I said back to him, 'My words have no effect on him. Please say something for me as his superior official.'"

-----Did he ever skip work because of a hangover at this time?

"Yes, every now and again he did. But that problem really became severe in the last ten years."

Generally, when a superior official cautions a worker about his bad drinking habit, it means that the person's drinking is quite problematic, even from an outside perspective. This means that it is likely that ten years ago, which is five years after his boss cautioned Natsuko about Ichiro's drinking, Ichiro's alcohol problem was quite severe. Around this

time, according to Natsuko, Ichiro became grumpy and frequently complained about small things for a long time. But, again, he seldom resorted to violence. In terms of violence such as pushing and hitting, she said she may have done it a lot more than he did to her.

-----By the way, did something happen at that time which led him drink so much?

“Well...his boss in Osaka was cheating the company for some money. And Ichiro was part of this. In other words, he was getting some pocket money through this, too. Well, it became known and Ichiro and his boss had to resign. In fact, it is more accurate to say that he was fired.”

-----And that led you to come back here in Tohoku again?

“Yes, that’s right. Although he was fired, he applied at the same company here again and was hired. But, he didn’t do well here either. One day, he was scolded by his boss because he smelled like alcohol during business hours, which led to a quarrel. He told me, ‘I am going to quit this job’ and quit the next day.”

-----Does this mean that he is currently unemployed?

“Yes. He is indeed unemployed.”

Hallucination

-----What was the cause of his hospitalization this time?

“He had hallucinations.”

-----Hallucination happens when one’s alcoholism is quite severe. Was it that bad?

“The doctor at the hospital told me that there are early stage, middle stage, and late stage in alcohol dependence syndrome; Ichiro is considered to be in the late stage.”

-----While hallucinating, what did Ichiro see or hear?

“He said that he could see a man that doesn’t have legs. He was talking about something which... ‘the body has the shape of PC [personal computer]...’ or ‘Big roses are men and small roses are women.’ Many things didn’t make sense. He was also saying that he sees abundant children, too.”

Hospitalization

-----Your husband is currently hospitalized. [Natsuko nodded.] Is he okay? Is he happy with his situation?

“When he experienced the hallucinations, I lied to him saying ‘I see it, too. It’s weird. Let’s go to see a doctor together.’ and took him to the hospital. Because of this, since it is only

him who is hospitalized, he has been complaining, ‘How come it is only me who has to be hospitalized?’ He therefore says to me, ‘I am going home.’ Or ‘My problem is a liver disorder, but this place is not doing any medical examinations that check my liver. I am hospitalized in a wrong hospital. I am therefore going home.’”

Natsuko continues.

“In other words, I can’t deny the fact that my husband was deceived and was taken to the hospital. He didn’t voluntarily go there by himself. The correspondence of the hospital was...quite proper, though. My husband was first diagnosed on Tuesday. At that time, the doctor at the hospital asked my husband, ‘Do you want to get hospitalized.’ My husband responded, ‘No, I don’t.’ The doctor’s response to this was, ‘Well, that’s fine. Let’s not get hospitalized, then.’ So that day, the examination didn’t lead to hospitalization. Since I was desperately hoping for him to get hospitalized, I was very disappointed by the doctor’s action. But thinking about it now, this move was actually a very proper thing to do for my husband. If we forcibly put him into the hospital, he would blame me ‘You are the one who forcibly put me into this hospital! You are the one who is bad!’ and frantically try to run away from the hospital. Fortunately, this didn’t happen. In the next examination, the doctor said to my husband, ‘Quitting alcohol and living without it is just one way of living your life. Just as living with alcohol is...that’s a wonderful life, too. Whichever you chose, it’s your beautiful life. If you want to quit drinking, however, we are willing to help you.’ When Ichiro heard this, it seems like he wanted to quit drinking, and so he said to the doctor he would like to be hospitalized. By the way, when people enter that hospital, they

must sign a document which says they were hospitalized based on their own will [not forcefully]. My husband signed and sealed the document himself. By doing this, his hospitalization was the ‘voluntary hospitalization’ and not the ‘compulsive hospitalization.’”

----- It sounds like the hospital has the know-how for treating their alcoholic patients.³⁴

Self-help group meeting

-----Do you go to the self-help group meeting at that hospital?

“Yes, I do.”

-----Tell me about any memorable advice or support you received from people since Ichiro became treated.

“The doctor at the hospital told me, ‘You don’t have any responsibility in this. If he happens to drink again, that is what he chose to do. It’s not your fault.’ This really decreased my burden. [Natsuko paused.] The doctor also asked me ‘[On a scale from 1-10] how much of the energy in your life do you use for your husband right now?’ I answered ‘9.’ In fact, in general it’s not that bad. It was 9 only since I had started part-time work one month before that. Because of his problem, I had to miss work the day before, half a day on

³⁴ This doctor respects the freedom of choice of the patient while at the same time skillfully directing him to the medically necessary treatment decision. In the end it is the patient who requests the treatment through the advice of the doctor.

the day I met the doctor, and the whole day again on the next day. This was during the busiest time at my workplace. Anyway, that aside, the doctor's response to this was, 'From now on, please use your free time unrestricted for yourself. If you have too much time to use for yourself, please use it for your children. If there is still some more spare time.... then you can use it for your husband.'"

-----Is there any other memorable statement that touched your heart?

"At the self-help group, I met a counselor named Masako. She told me not to repress myself. Until then, I had a tendency to repress and kill myself by saying to myself 'Don't say it.' or 'Don't fight back.'"

She continued.

"At the hospital, the patients are allowed to leave the hospital once a week. During the first week and second week when Ichiro left the hospital, he came to our house and told me, 'This hospital is the wrong place. I am going to get out of here.' At that time, although I became upset when I heard this, I didn't say anything. But after I learned that this self-repression is not good for me, when he said the same thing the third week, I replied. 'You said you wanted to get hospitalized to get better. The reason you are hospitalized for three months is because you wanted to quit drinking. You haven't finished the psychological treatment either... You are not cured, yet.' Ichiro didn't look like he was pleased to hear me say that, but he didn't argue either."

Ichiro's awareness of his disease

-----Do you think your husband is aware of his alcohol dependence syndrome?

“He is saying something like ‘I don’t have alcohol dependence syndrome.’”

-----Possibly, although he behaves as though he doesn’t admit to his problem, he is aware that he has a problem. Do you think your husband, in his heart, recognizes that he is an alcoholic?

“Yes, I do. Although he doesn’t admit that he is alcoholic, I think in his heart, he is aware of his drinking problem very well. I want to believe so.”

After the hospitalization

-----What kind of life are you expecting after the hospitalization?

“Since I am not sure if the treatment will succeed, I haven’t really thought about that yet. I am very nervous. [Natsuko paused.] If he leaves the hospital early, I am thinking to say, ‘Please return to the hospital.’ or ‘Let’s get divorced.’ However, if he accomplishes the 3 months hospitalization without much problem, I am thinking to continue our relationship. I will try to be normal as I used to be. If possible, I want to spend a quiet life.”

The reasons for Ichiro's excessive drinking

Hypothesis 1: strong sense of responsibility

-----What do you think are the reasons for your husband's drinking?

“Stress is definitely a factor. He was often drinking when he was not on good terms with his work mates. [Natsuko paused.] And, this is just my opinion, but I think he has a very strong sense of responsibility such as ‘I *should be* a good father,’ ‘I *should be* a good husband,’ I *should be* working hard.’ It seems to me like he carries a very idealistic image of himself and if he can't achieve the ideal principle, he wants to close his eyes to the reality. In this situation, alcohol is the means of escaping from the reality. I think he wants to drink to become numb, to not be able to think consciously.”

Natsuko said she has carried this view for more than ten years.

-----Does your husband burden himself with such responsibilities that much?

“Yes. I think he thinks too much. I don't know why. For example, he has a tendency to do things for his parents more than the parents themselves expect him to do. And since things don't work in the way he wants, he is unsatisfied and consequently feels bad about himself. At least that is what it looks like to me.”

Natsuko looked as if she remembered something and started talking again.

“Oh, yes. I just remembered this story. It was about eight years ago. It was during the New Year holidays or the Christmas holidays. We had a plan to visit his parents’ house. Perhaps it was because my mother-in-law did not want to deal with her son who had bad drinking habit. She called me beforehand and told me politely that there is no obligation for us to stay at their place overnight. So, just before we left our house, I casually said to Ichiro: ‘Why don’t we return home on the same day?’ When I said this, he became mad with a ferocious face. He was thinking to stay over night at his parents’ house and scolded me, ‘You are refusing to stay at my parents’ house! Why do you do that?!?’ I explained to him that it was because his mother had called me and actually said to me not to stay at their house overnight. It seems like he couldn’t believe that his mother actually said such a thing. He called his mother and verified my story at once. Since I was right, he started suspecting that his mother and I were in a group trying to shut him out. He became very upset. I think he felt as if he had lost his position in the family.”

-----By the way, your relationship with your mother-in-law is quite strong, perhaps stronger [or less problematic relationship] than the relationship between your husband and his mother.

“Yes, that’s true.”

-----Is this also the case with your relationship with your sister-in-law?

“Yes, my sister-in-law is definitely on my side. She also listens to my problems about Ichiro’s drinking; regarding this hospitalization, too. If there had no help from my sister-in-law, this hospitalization would have been impossible.”

Hypothesis 2: Born as the first son

-----Your husband is the first son. Do you think his strong sense of responsibility comes from the fact that he is the first son?

“Well, it could be... As I said, Ichiro does seem to carry a strong sense of responsibility to look after his parents.... But I am not sure if it is *the* cause for this personality.”

Hypothesis 3: Dependant personality

“About five years ago when I started to seriously think about Ichiro’s drinking problem, I started to study this issue by reading books or going to a public lectures about these problems. One such day, I happened to do a psychological test called *ego-gram*. It was a test which measures one’s level of ego by asking simple yes/no questions. I took the test home and let my husband answer the questions, too. Through this I learned that Ichiro has a dependant character. In addition, the test also indicated that although he has a strong sense of responsibility—such as I should do this and that—he rarely puts those thoughts into actions.”

Was she trying to make a point that he became alcohol dependant because of his dependant character? Although I was intrigued by this statement afterwards when I was analyzing the

data, I had not explored this subject further during the interview. The meaning of this statement is therefore unclear to me.

Hypothesis 4: Strict father

-----How about a possibility of his father being a too respectable figure for Ichiro, which put him under pressure to do well in society?

“One day, Ichiro said to me, ‘I respect my father as a *salaried-man* [=worker]. I grew up in a family where my parents were farming for a living and we don’t use this word ‘respect’ towards our parents. I therefore felt strange when I heard Ichiro respecting his father. By the way, I think the father is quite a strict person. When Ichiro was young, that is when he was a junior high school or high school student, his father tied him to a tree in the garden because of some wrongdoing. When I heard that, I thought, ‘What a strict father!’ and ‘What a scary father!’ I also noticed that Ichiro’s family has a tendency to compare people such as comparing my children with my sister-in-law’s children. Comparing which one is more splendid and so on... I think this kind of family environment can put great pressure on children. Don’t you think so?”

Hypothesis 5: *Aijou-busoku* [lack of love]

-----Sometimes people say, ‘The reason my husband drinks is because of his so-called *aijou-busoku* [Lack of love] problem.’ Do you think that reason applies to your husband?

“Ichiro says ‘Let’s take *obento* [home-made lunch box].’ every time we go out for something. Since I want to eat something special, something unique to that place, I refuse to do this. But, he insists on taking *obento* to the field more than I would like. Strangely, when I make the lunch and take it with us, he doesn’t necessarily eat it with great pleasure. He even leaves some food, too. It seems to me that actually eating the lunch box does not have much significance. The point is to take the home-made lunch box when we go out for leisure. I often thought, ‘Why does he insist so much on taking home-made lunch box?’ And I think I understand why by seeing his childhood school album. There was a picture of a school field trip. In the picture, I noticed, he was eating a bought lunch-box while his friends were eating home-made *onigiri* [rice balls]. According to Ichiro, he was always buying his lunch box at a store throughout his school time.”

Hypothesis 6: Inferiority complex

-----Do you think your husband has any kind of inferiority complex? Anything such as physiological, educational, etc.

“My husband is not a university graduate. He graduated from a two-year college. I haven’t heard any complaints from him because he is a two-year college graduate, though. Maybe he doesn’t want to think about it at all. I don’t know.”

Natsuko

Compared with other interviewees, the interview with Natsuko was a cheerful conversation which involved occasional jokes in between. She didn’t seem to overly protect her husband

nor did I notice much anxiety which is commonly observed among the wives of alcoholics who are in the midst of their family problems.

-----You have been telling me your story, and so far, honestly speaking, from your story and behavior, I can't sense the traits commonly observed among alcoholics' wives in you. What I mean by "commonly observed traits" is like the behavior of "*Miyako Harumi suru*" [Behave like Harumi Miyako, a popular female Japanese folk singer. Since her songs often express sacrificial love, this phrase became a popular expression to address a person's behavior of sacrifice, especially for love.]

"[Natsuko laughed] ♪♪*Kitewa moraenu seta wo, namida koraete andemasu...*[I am holding my tears while knitting a sweater for you, the sweater you will never wear...] ♪♪, right?"[One of Harumi Miyako's famous songs.]

-----Right. [I laughed back.] Why is that? It is commonly said that spouses who became acquainted with alcoholics have some kind of background, such as family background, that made them become fond of problematic people like alcoholics. Do you think you have any problem which may be the reason for being an alcoholic's wife?

"That's the thing! I really don't have anything that comes to my mind for being an alcoholic's wife!"

----- Please let me ask this, just in case. Did your family have any of the following family problems such as gambling addiction, physical disability, workaholism, mother-in-law problems?

“I can’t think of any at this point....”

-----You told me that your family was doing farming for a living. Was that a “traditional patriarchal family” where the father, as the head of the family, dominantly ruled the house?

“Well, yes. Our family was rather a feudalistic household.”

-----Hmm. Feudalistic... Is that like the house where the family members fight over the property such as for the farm land?

“Yes. Since my father was the first son, all his siblings, except for a sister, [had to] renounce their right of inheritance. The only one who claimed her inheritance was his older sister who was divorced [she probably depended of this property]. This incident caused so much trouble. Because of this, this sister is not allowed to enter my parents’ house, even now.”

-----How about your mother as a woman who married into this house? Did she suffer from the problem where she wasn’t able to express her feelings?

“Yes, when I was in elementary and junior high school, my mother listened to everybody’s word without any complaints. She doesn’t have that problem now, though. Truly, she is having the best time of her life right now.”

Studying about alcohol dependence syndrome

I was not satisfied. In my mind, Natsuko’s experience as an alcoholic’s wife or her family background did not connect well with her frank or cheerful character that I observed. In a certain sense, her behavior was too normal for an alcoholic’s wife. I muttered involuntarily:

-----I’m not convinced... Something is missing... [I muttered with a troubled face and tried to find a question that would make sense of this problem.]

Natsuko then started talking from her own accord.

“Well... There was a period for me, too, when I was acting as an enabler. I called my husband’s workplace and talked to his boss, saying that he is going to miss work when Ichiro was missing work because of a hangover. I accompanied his *banshaku* [drinking with meals] in order to watch his drinking. I also hid the alcohol bottles on the veranda or made a mark on his bottle to check how much he was drinking.... But since a book told me that doing something like this is not good, I stopped it. Until I read this book on alcohol dependence syndrome, I had a strong sense of anxiety all the time. Like you said, I was living with anxiety really every single day. But by learning about it through the book or through various other means, I became knowledgeable and my feelings became a lot easier.

[Natsuko paused.] Various things were written in that book. It said, for example, ‘the commonly seen attitude of wives, that they want to cure his alcohol problem for him, is not a selfless intention as one might think. The real intention behind this is often their selfishness for their own sake or for the sake of their family’s living.’ When I heard this, I thought, ‘Yeah that’s true. I used to think that the anxiety I was having and my desire to change him was for his sake, but it wasn’t, really. My real intention was for the sake of my life. I realized my selfish intention and noticed the problem on my side, too. Since then, I became careful with my words.’”

-----When did you start studying about this? For instance, when did you read this book?

“I started studying this five years ago. I think I read the book about four years ago. By learning more about alcohol problems, I started perceiving his alcohol problem as a disease. Every time I encountered a problem, I said to myself: ‘Don’t lose your mind, Natsuko. You have to understand this as a disease.’”

Divorce

-----Have you ever thought about divorcing him?

“Until recently I haven’t. But, these days, I start thinking divorce would be good for both of us. First, it is for me, because my mind is very peaceful right now. Yes, working outside is tough. But considering the peaceful mind I have right now, it might be a lot more important than living with a [financially dependable] husband and constantly having anxiety. When

we are together, we often fight over alcohol.... Both of us take truculent attitudes, and that isn't good at all. [Natsuko paused.] Second, it is for my husband because I myself am an enabler and I haven't totally solved that problem yet. I think someone like me surrounding Ichiro is not good for his recovery either."

What might have been good for Ichiro

-----What do you think is necessary for Ichiro right now?

"This is not about what he needs right now, but...I sometimes I think that it might have been better if he had been living with his parents. In that case, he might not have experienced these negative feelings, such as his sinfulness. I sometimes think that he drinks to escape from reality because he is living with me and feels that he is bad or a weak man. I can't praise people. [≈I am not good at putting him up and encouraging him to live his life positively.] You see, it is only these days that I can finally say 'Thank you' to people."

Is she saying that she has a tendency to put her husband down? Since this topic was not explored, further explanations of the above statement are unavailable. This could be a possible hypothesis for the reason of Ichiro's drinking from his wife's perspective, too.

For me, there is a difference between wives who are connected to the self-help group and those who are not, in terms of attitude and their way of thinking. Although this is not always the case, many wives who are connected to the self-help group are often honest about their feelings and are not willing to force themselves to do things they don't want to

do. In contrast, wives who are not connected with self-help groups have the tendency to be in denial [or they might have difficulties articulating their problems in the first place] and sometimes pretend not to have any problems. For these people, I also sense anxiety in their attitudes, which probably comes from the fact that they have a bleak future. Although Natsuko was not absolutely free from anxiety, I had the impression that she shared more characteristics with wives connected to self-help groups than those who are not.³⁵ This character probably comes from her long time of self-education about alcohol dependence syndrome. From this, I started to think that there are ways for alcoholics' wives, who are unwilling to attend self-help groups because of the negative stereotype attached to the word alcoholics, to recover from alcohol-related problems. If avoiding shame is the most important aspect of their life, it is still possible for them to regain their strength through learning about the issue through books, TV shows, or public lectures which are available these days. At least Natsuko's case showed me the possibility of recovery through such means.

³⁵ Natsuko started attending self-help groups only recently.

Case 17. I asked the doctor to tell my husband that his disease is very serious.

Name				Age		Occupation								
Tamayo Aida				70		Housewife								
Family						Husband's Occupation								
Nuclear		Extended		# of members		6		Police officer (retired)						
Family members														
Ichiro		Husband		77										
Tamayo		Wife		70										
Kazuo		First son				Alcoholic (necktie-alcoholic)								
Norie		Kazuo's wife												
Ichi		First grandson		22		Hikikomori [Shut himself in from society, see glossary on page 555]								
Tsugiko		Granddaughter		18										
Total Interview Time				Wife Attending Self-help Group?				Husband Attending Self-help Group?						
1 hour 40 minutes				Yes No				Yes No						
Wife's KAST concerning her husband's alcohol related behavior (See Appendix 1 on Page 546)														
1	2	3	4	5	6	7	8	9	10	11	12	13	14	Total
3.7	3.2	2.3	2.2	2.1	1.7	1.5	1.2	0.8	0.7	0.7	0.6	0.5	0.5	≈8.4
-1.1	-1.1	-0.8	-0.7	-0.7	-0.4	-0.5	-0.2	-0.2	0	-0.1	-0.1	0	0	
?	?	?	?	?	?	?	?	?	?	?	?	?	?	
Analysis (See Analysis on Page 489)														
A1	A2	A3	A4	A5	A6	B7	B1	B2	B3	B4	B5	B6	G1	
C1	C2	C3	C4	C5	C6	D7	D1	D2	D3	D4	D5	D6	D7	D8
E1	E2	E3	E4	F1		H1		H2	H3	H4	H5	H6		
Types of Problems (See Analysis on Page 489)														
Verbal Abuse		Physical Abuse		Financial		Psychological		Shirinugui		Child-Related				
Note														

Tamayo Aida

Tamayo's husband, Ichiro, (77 years) is currently hospitalized for the second time because of cardiac insufficiency. Contrary to Tamayo's belief that the disease is caused by his excessive drinking habit, Ichiro strongly disputes that by insisting that his disease was not caused by alcohol. Because of his strong denial, last time when he was released from the hospital, he started drinking the same day for *tan-in-iwai* [Congratulation for leaving the hospital]

To not let that happen again, Tamayo is asking Ichiro's doctor to strictly make Ichiro realize about his drinking problem. However, contrary to her expectation, her husband still denies his problem. When she asks him, "What explanation or advice are you getting from your doctor?" he answers, "The doctor says that alcohol is not solely the problem of my disease."

"He doesn't listen to my advice at all. I am hoping that he will listen if someone like the doctor puts him in to a perspective strictly.... But unfortunately, this intention apparently hasn't been properly understood by the doctor."

She is currently very worried about Ichiro after he leaves the hospital since there is a great chance that he will start drinking again like the last time.

Drinking started after retirement

Since alcohol itself was a luxury when Tamayo and Ichiro got married [more than 50 years ago], she says, she had not even considered that drinking may become a problem, at all.

“At that time, drinking alcohol was considered extravagant. I used to go to the local rice shop and buy 1 *gou* [≈ 0.18 liter ≈ 0.05 U.S. gallon] of *sake*. In those days you had to bring the bottles to the shop and they filled them. Ichiro usually had this precious *sake* only once a month for his payday’s dinner. With my young husband’s low salary, it was all we could afford. It was our ‘small pleasure’ at that time. He drank only once a month, and eventually when we had a little more money to spare, he drank only on Saturdays. In those days, however, he never drank and reeled along as he does these days. [Tamayo paused.]

Honestly speaking, my husband’s heavy drinking started only after he retired. Before his retirement, he was very careful about his nutrition including the amount of alcohol he drank since he was a stoic policeman. It was only after retirement, when I started noticing his problem. When I noticed his frequent drinking, I simply thought ‘Why does he drink so much?’ This feeling however eventually became worse and, as time went by, became the center of my concern. These days, there are always excuses for drinking. First of all, he drinks every day at night as a daily habit. But when his friends come to visit, he drinks during the daytime, too. Sometimes, after his friend leaves the house, he starts drinking again, too. Sometimes, I say to him, ‘You have already had the drink of the day for today.’ But when I do this, he complains. Drinking with friends is a separate thing from drinking alone: socialization drinking is for socialization and drinking alone is for relaxation.”

Drinking alone in his own room

Ichiro usually drinks alone in his room.

“Our house has many visitors every day. Usually, he stays in his own room and is drinking alone throughout the day. Except when his drinking friends visit, he doesn’t socialize with outsiders at all. He carries food and alcoholic drinks to his room, and drinks while watching television. He does this every day which is literally 365 days a year. Since I don’t want to quarrel in front of our guests whether he drinks too much or not, I seldom complain about it to him. It’s easier for me to just leave him alone. There is therefore a fault on my side for letting him do whatever he wants to do.”

Hearing this, I briefly wondered if the wife overlooking her husband’s excessive drinking habit because she is too busy to take care of him could be considered as enabling. (Enabling in the sense that it made his excessive drinking possible.)

Husband’s drinking habit

-----How much does your husband drink in general?

“I can’t really tell. He drinks whisky. I don’t know what brand he drinks since he is very particular about alcoholic drinks and cigarettes. I can’t deal with this problem since he complains all the time when I buy things for him: this brand, that brand, at this shop and at that shop etc. I therefore say to him, ‘If you are complaining so much, then please go to the store by yourself and do it by yourself.’ The same is said for how he wants his drinks to be. Usually you mix water with the whiskey, like 2/3 whiskey and 1/3 water, right? When I do it for him, I always do it in the wrong way. I think the drinks I make are too weak for him. Since I don’t want to get into a fight, I let him do it by himself, too. This is the reason why I

don't know what kind of brand nor how much he drinks. He seems to mix water into the whiskey, but, from my perspective, it's quite dark."

-----Do you know roughly how many days it takes for one bottle to get emptied? And what kind of bottle is it?

"Usually the 2.7 liter whiskey bottle [It sounds like the cheapest brand for whisky.] is emptied in a week."

No alcohol related problems

-----Did your husband ever have alcohol-related-problems before he retired?

"No, he didn't."

-----How about after he retired?

"No, he doesn't have it at all, either. He doesn't resort to violence. He doesn't grumble about his problem. He doesn't have any effluence. He doesn't become deadly drunk. Although he often can't walk properly when he is drunk, but that doesn't mean he lies on the floor or at the corner of the room. He always goes to the bed responsibly by himself to go to sleep. In these respects, he is not problematic at all; He doesn't require any help from us."

-----Considering the fact that he drinks at home, there must be no alcohol-related traffic accident, alcohol-related quarrels with other people, nor the bar's Mama calling you to pick your husband up either, right?

“Yes. He is absolutely free from these kinds of problems.”

-----Since he started drinking a lot after his retirement, he doesn't have the experience of drinking too much and missing work the next day, too, right? [Tamayo nodded.] He doesn't fail to provide you with household income because he is spending the money for his drinks, right? [Tamayo nodded.] In other words, he doesn't have any typical alcohol-related-problems; he just has the habit of drinking a lot every day, right?

“Right. My husband doesn't have the problem which is usually considered alcohol problem. He accomplished his work in a satisfactory manner. Of course he didn't work as a part-time worker after his retirement like many other people do. However, that doesn't mean we are starving. We are living on his pension without any financial difficulties.”

Relevancy of Tamayo's story

I asked Tamayo in various ways to verify her story that her husband was free from alcohol related problems before the retirement. Her stories were consistent in that “Ichiro did not have drinking problems before retirement” and “his excessive drinking only started after his retirement which also changed his lifestyle from the ‘stoic-responsible lifestyle’ to the ‘be-lazy-and-drink-and-do-whatever-you-want lifestyle.’” I have heard about and

encountered men whose retirement was the occasion for their increase in alcohol. Although I never encountered a man who was absolutely free from alcohol-related-problems in the past but became fond of alcohol so much after retirement, as in the case of Tamayo's husband, this case may not be unique to Tamayo's husband.

The reasons for Ichiro's drinking

-----Why do you think your husband suddenly started to drink a lot after his retirement?

“As you might guess, I think he had more spare time after he retired than he could actually manage. In that circumstance, his mouth seeks something. Just like we drink tea every day, he is drinking alcohol. Alcohol is a substitution of tea for him, I think. [Tamayo paused.] In addition, I think there is an aspect of him exploding or popping after his retirement. Until then, he was living a stoic military-like lifestyle. He was hard working and precise when it came to work. He didn't take any advantage of the paid vacation. Throughout his career, he made a lot of effort. In this sense, we, as a family, appreciate his effort a lot.”

-----It sounds like he has accomplished his “big task” and now finally is his “real vacation”; carrying food to his room and watching television.... I envy him a little bit, honestly speaking. [I said this involuntarily and smiled. Probably I am not the only one who thinks in this way. Then I started to think that this typical way of thinking may be the obstacle to Ichiro's alcohol treatment which has not been undertaken properly.]

“Indeed. You surely have a point there. [Tamayo repeatedly nodded deeply.] I think he regards his present life as heaven. He finished what is usually considered as ‘men’s life duties.’ There is almost no one who blames him anymore. He accomplished his career life very well; he cleared his children off [=they are all married]. In addition to that, he is not causing any trouble to others such as by drinking and quarreling with somebody else. Because of his accomplishments, I therefore used to think that it’s okay for him to drink as much as he wants. But, now that he is physically ill like this..... [Tamayo looked troubled.] Honestly speaking, I am very surprised that my husband happened to have a problem like this...”

Ichiro’s condition

As described, Ichiro is currently hospitalized because of cardiac insufficiency. His liver is not bad, but he has high blood pressure.

-----Does he have sleeping disorder?

“Yes, he does. For a long time I have been suffering from sleeping disorder because my husband sneezes because he drinks a lot. I have long been taking sleeping pills. One day, he asked me, ‘Hey. Weren’t you getting the sleeping pills from your doctor? Could you give some to me?’ He was taking it with me for a while.”

-----Does he lack any memory because he drank a lot the day before?

“Oh, yes. Oh, yes. [Tamayo seemed thinking.] For example, when I asked him to exchange the batteries in the flash light, he agreed on the spot but forgot about it completely afterwards.”

-----Is that because of his drinking or because of his forgetfulness in general? It can also be due to his old age, too. You see, he is 77 years old.

“Right. Compared to him, I might be more forgetful. [Tamayo is 70 years old.]”

-----Does he have any of the followings troubles: bad temper, shaking fingers, visual hallucination, or auditory hallucination?

“His fingers are trembling. Because of this, he can’t write. I usually write letters for him: congratulation cards for someone’s wedding, entering new schools, etc. I am not, however, sure whether this symptom comes from his excessive drinking or from his age. [Tamayo looked as though something came up to her mind.] Also, he is often saying something by himself.”

-----Is he talking to himself? Is he grumbling?

“That I don’t know. Nobody can tell what he is saying since many people in our family don’t really care about him. Anyway, I don’t think he is grumbling. I think so since he did

not use to grumble in general in the past. Whenever I complained about other people, he used to advise me not do so. By the way, he sweats a lot, too”

As in the case of forgetfulness, Tamayo isn't sure whether all these symptoms which can be symptoms of alcohol dependence are caused by his excessive drinking. It is possible that they are symptoms of old-age, too.

***Shizuka na aruchu* [Quiet alcoholic]**

----- [I muttered] Started drinking excessively since his retirement... [Tamayo nodded.] He doesn't cause trouble to others... [She nodded.] Since he drinks at home, there are no police incidents such as quarrels or traffic accidents... [She nodded.] He doesn't become quarrelsome... [She nodded.] And so there is no domestic violence problem... [She nodded.] Since he is not working anymore, drinking doesn't interfere with his work-life... [She nodded] Moreover, since he has been working hard for the family, family members like you respect him... [She nodded.] The only problem is that he has physiological problems due to his excessive drinking, correct?

“Correct.”

-----Hmm. [I muttered.] A so-called “*shizuka na aruchu* [quiet alcoholic, see glossary on page 556]”....

When she heard ‘*shizuka na aruchu*,’ Tamayo chuckled.

Tamayo's suggestion for public services

-----Is there any support or help you want from public services or from your friends for the problem you confront? Wait, but you don't have a problem in the first place; this question should therefore be irrelevant, isn't it?

“Yes. Since we don't have any problem like a big fight, I have never even thought of divorcing him. Since however he is a man who rarely leaves home, I want him to go outside more frequently.”

-----Hmm. None of the typical problems except for his physiological problems.... [I muttered.] I was searching for questions that may enable us to articulate her problem if there was any problem as a quiet alcoholic's wife. While I was thinking about it, Tamayo spoke out voluntarily.

“Urr... I wish the doctor could make my husband realize his disease more. As I said, he is not aware of his alcoholism problem, and because of this, he started drinking on the day he left the hospital in the name of ‘congratulating for leaving the hospital.’ Since I don't want this to happen again, I asked the doctor to tell him that his disease is very serious. I even asked the doctor to exaggerate his disease so that he will take it more seriously. Recently, I said to the doctor, ‘When Ichiro leaves the hospital, please call a meeting for the family and Ichiro and fully explain to us about his illness.’ You see, our frantic effort is useless if he himself is not aware of the problem. The reason I asked the doctor is because there is a

possibility that he may listen to the doctor's words. Unfortunately, he doesn't listen to us, at all. But unfortunately, my intention is not properly understood by the doctor. When I ask Ichiro what advice he received from the doctor, Ichiro told me, 'The doctor says that drinking is not the sole problem of the disease.' It seems like he is still not aware of his problem. [Tamayo paused.] I also want clear instructions from the doctor to my husband. Last time when he was hospitalized, the doctor seemed to say to him, 'It is okay to drink if it is only a little bit.' What does this 'a little bit' exactly mean? I want the doctor to clarify this kind of ambiguous phrase. If someone says it means 'one cup,' my husband will without any hesitation interpret it as 'one big mug' instead of 'one shot glass.' Because of that character, I want the doctor to teach him clearly about the things he should and should not do. Without it, I'm sure that our problem will persist."

Abandonment by the side of medicine

I thought about the possibility of medical specialists abandoning Ichiro's problem since his age makes the specialist think that it's better (or easier) to leave him alone instead of going through the torturous difficulties of educating him and getting him to abstain. I have heard of such cases from a different source. I involuntarily expressed that thought to Tamayo.

-----Well, he is seventy-seven years old. Considering the difficulties attached to abstaining, perhaps the medical professionals think that it's better to leave him alone rather than diagnosing him with alcohol dependence syndrome and making him go through the torturous treatment. He is a retired man, you see...

“...”

-----[What a thoughtless thing I have said to an alcoholic's wife! I regretted what I said and tried to make up for it.] Well, of course this is not a good thing especially if Ichiro, who denies his alcohol problem, continues to drink every time he gets out from the hospital. Although his problem doesn't need help at the moment, there is a great possibility that his alcoholism becomes worse and therefore requires your or family member's help in the future. If that happens, that will be problematic for you.

"Yes. As you said, I have long been thinking, 'let him spend his rest of his retired life as he wants since he is retired.' But this led him to physiological disorders and that is really a problem for the person who has to take care of him. But what can we do? He doesn't admit his problematic drinking in the first place. [Tamayo looked troubled.] If possible, I want him to stop drinking in the way he is drinking right now and make good use of the precious life left for him."

I thought about the damage induced by the medical specialists abandoning the patient's alcohol dependence problem due to the patient's old age. Although this *may* be a thoughtful action for the alcoholic himself, the life for the family surrounding the alcoholic, especially his wife or his daughter-in-law, can be very devastating. If this is happening on a societal level, awareness to such misleading treatment with more consideration put on the perspectives of family members is necessary.

If Ichiro drinks after he comes back home again...

-----What are you going to do if your husband starts drinking again after he comes back from the hospital? [What a cruel question to ask!]

Tamayo looked as though she was surprised and started brooding over to the matter.

“Wha...what can I say...um...”

-----What happens if he asks you to go and buy some bottles for him right after he gets out from the hospital?

“I am determined not to go out to buy drinks for him.”

She looked as though she was saying this to her self, too.

-----What happens then if he asks your daughter-in-law or his grandchildren to buy alcoholic beverages for him instead of asking you?

“I don’t think he will ask his daughter-in-law since he always behaves politely in front of her. If he is going to ask, I am sure he is going to ask me. He will watch for the moment when I am alone, and will ask me for this favor. But, I am really not thinking to do that this time. I am presently thinking not to get involved in any of his drinking businesses. If he asks me to go out to buy drinks, I am thinking to run away and hide somewhere. When this

happens, he might go out to buy drinks by himself. Hmm.... Since the doctor advises my husband not to do harsh physical activities, this can be a problem. [Tamayo made a troubled face.] He is only allowed to do easy garden work at home... If he is going to buy alcohol, he has to go to the shopping center in the neighboring town... I wonder if he can carry three liter bottles by himself. Hmm. [Tamayo looked as if her plan may not work as she had thought.]”

Tamayo’s comment that Ichiro is a problem drinker

The interview was approaching its end so I started to round it off.

-----Well, thank you. It was especially interesting for me to learn about your case where there is no problem. Since there is no problem, there is also no request for improvements. Actually, you did mention about the role of the doctor who can make the patient become aware of his alcohol problem. Yes. I will make sure those are properly documented in the report. [I muttered.]

Probably to my remarks that Ichiro has not problem, Tamayo replied.

“Well, but everybody says that he has drinking problems. I also think that his drinking goes beyond the limit of normal drinkers, too. I think so all the time. Not only I but also my siblings and his siblings think in this way. No one directly says to him ‘You are a drinker’! or ‘Grandpa, you are drinking too much!’ but I think everyone in the family, in their hearts, is quite annoyed by his drinking behavior.”

Patient character of Tamayo as being an obstacle for realizing her problem as a problem

According to the person who introduced Tamayo to me for the interview, her son Kazuo is also an alcoholic and his wife is suffering. When I asked Tamayo about her son, however, she replied that her son is not a problem drinker.

“No, he doesn’t have a drinking problem. He drinks, but I don’t think he is an alcoholic. Compared to Ichiro, I think Ichiro drinks a lot more. I think he is a lot more troublesome, than Kazuo.”

Whose statement is accurate: Tamayo’s or the person who introduced Tamayo to me? There is a possibility of her trying to conceal the problem since it is usually considered shameful in society. There is also a possibility that her patient character is an obstacle to realizing her son’s problem. I hypothesize this to be the case based on her remarks during the interview.

“I married into a family where parents-in-law were Meiji born people [Meiji born people are said to be strict in Japan since they were brought up in a poor environment.], so I can tolerate almost anything in my life. [Tamayo humbly laughed.] I followed all commands without any complaints. So, compared to my old days, I think this problem is nothing, really nothing to worry about at all.”

Deemphasizing the problems is problematic for an interview like this since it will act to maintain the current situation. It is, however, understandable that she can't change her patient character to suddenly become a whiner for the sake of interview. Although I thought there is a great potential of problems being hidden in this case, the time was up and I had to conclude the interview for the time being.

Tamayo's case is a case in which the alcoholic himself does not have typical drinking related problems [e.g. domestic violence, quarreling with people, or missing work because he drank excessively.]. Although it appears to be problem-free at first glance, there is some potential that there are problems hiding which were not covered in this interview. For example, according to Tamayo, the family members are always careful not to upset Ichiro when he is drinking. Her son may be alcoholic and her grandson is *hikikomori* [shutting himself away from society, see glossary on page 555]. Tamayo's case is also the case of old people's alcoholism problem. It describes the situation of the alcoholics not violating the Japanese criteria of alcoholism—not missing work because of his hangover or quarreling with his colleagues because he was drunk—therefore leading them to disregard the possibility of the husband's alcoholism problem. This case also pointed out the tendency of medical specialists to not take the treatment for the disease seriously because of the patient's old age. Since Japan is an aging society, there is the possibility that the old people's alcoholism will become more serious in the future.

Case 18. I do not think that there is especially a [drinking] problem in my husband.
 But that might just be because I am good at adjusting to him. You see...I am *ki-ga-yowai* [≈unconfident and timid] person.

Name				Age	Occupation																			
Fumiko Hanada				63	Housewife																			
Family				Husband's Occupation																				
Nuclear		Extended		# of members	6										Steeplejack then taxi driver (now retired)									
Family members																								
Ichiro	Husband			70	Diagnosed with hyperlipidemia, diabetes, urisemia,																			
Fumiko	Wife			63																				
Kazuo	First son			37																				
Tsugie	First daughter			35																				
Mitsue	Second daughter			31																				
Total Interview Time				Wife Attending Self-help Group?					Husband Attending Self-help Group?															
1 hour 50 minutes				Yes No					Yes No															
Wife's KAST concerning her husband's alcohol related behavior (See Appendix 1 on Page 546)																								
1	2	3	4	5	6	7	8	9	10	11	12	13	14	Total										
3.7	3.2	2.3	2.2	2.1	1.7	1.5	1.2	0.8	0.7	0.7	0.6	0.5	0.5	≈7.1										
-1.1	-1.1	-0.8	-0.7	-0.7	-0.4	-0.5	-0.2	-0.2	0	-0.1	-0.1	0	0											
?	?	?	?	?	?	?	?	?	?	?	?	?	?											
Analysis (See Analysis on Page 489)																								
A1	A2	A3	A4	A5	A6	A7	B1	B2	B3	B4	B5	B6	G1											
C1	C2	C3	C4	C5	C6	C7	D1	D2	D3	D4	D5	D6	D7	D8										
E1	E2	E3	E4	F1			H1	H2	H3	H4	H5	H6												
Types of Problems (See Analysis on Page 489)																								
Verbal Abuse	Physical Abuse			Financial			Psychological			Shirinugui			Child-Related											
Note																								

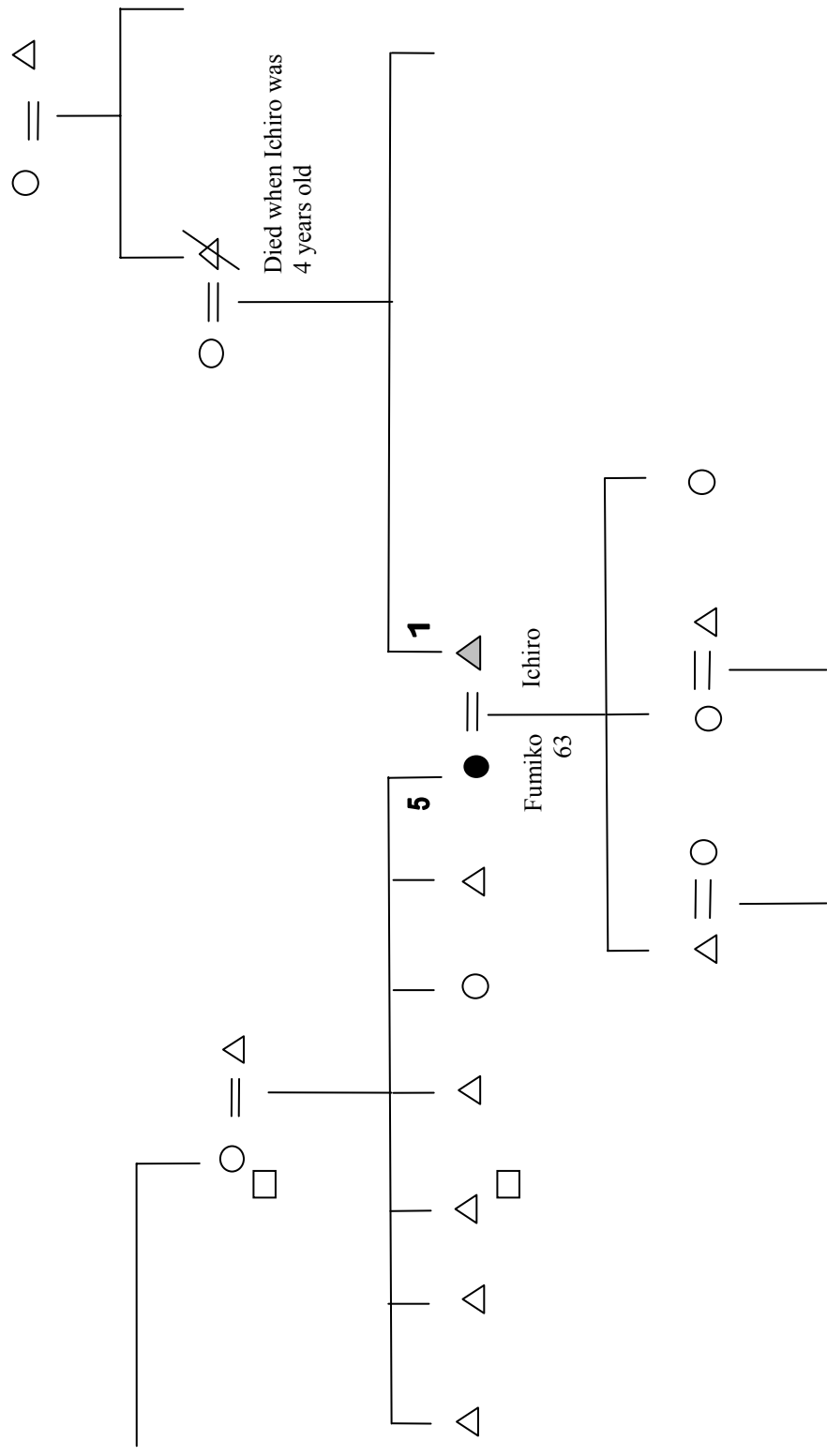

Fumiko Hanada

Fumiko's story does not have a particular unique aspect compared to those of other interviewees. She is a relatively quiet person, not talkative. There are, however, two reasons why I decided to include this case here. The first reason is because her husband is near the border of non-problematic and alcohol dependence syndrome [explained below]. The second reason is because I surmise that her case is not particular to her, but rather something that may exist on a societal level. Her case is a situation where an (apparently) decent family's wife is living with a husband of whom she is not sure if he is problematic drinker and therefore she is not sure if the family has a problem or not. This happens due to her patient and somewhat placid character despite the discontent she bears in her mind.

Fumiko

I was introduced to Fumiko by her friend whom I knew from a self-help group. I was advised by her friend that she may not understand why she is being interviewed in this study since she doesn't seem to perceive her husband to be a problematic drinker. This advice was helpful since she looked nervous when we first met. I spent more time than usual for greetings, small talk, and explanations about my research to reduce my tension as well as hers.

-----If I asked you to introduce your self in 3 lines, what would you say?

“I am *ki ga yowai* [≈unconfident and timid]. And I have a tendency to follow what people say to me, too. Since I am *ki ga yowai*, I can't deny people.”

-----Does that mean you couldn't deny participating in this interview, too? [I was half joking.]

“Oh, no. That's not what I am saying. [Fumiko smiled.]”

-----Do people say that you are a kind or a nice person?

“Yes.”

About the husband

-----What kind of person is your husband?

“Unlike me, he is unyielding. He does get mad sometimes.”

-----Which was closer to his character when he was young, “honor student/serious type person” or “juvenile delinquency/ bad type person”?

“He was definitely a juvenile delinquency/ bad type person. He was bad, very bad. He started drinking when he was in junior high school. [Fumiko laughed.] He says he was the villain around this neighborhood when he was young.”

-----What does he do for a living?

“He is a taxi driver. Originally he was a steeplejack, but couldn’t continue his work since he fell from a building and got injured. That’s the reason why he became a taxi driver... He retired about 10 years ago, though. So he is not working anymore right now.”

-----Was he a serious worker?

“Ohhh yes. He was a very serious worker. When it came to work, he was always serious. Since he is a perfectionist, he was more serious than just a serious worker.”

-----How are you making your living right now?

“We have a few buildings for rent, so we receive income from the rent.”

How Fumiko met Ichiro

-----How did you meet Ichiro and get married?

“It was an arranged marriage. I got married when I was 20 years old.”

-----Were you informed about your husband’s drinking habit before marrying him?

“Not particularly. But, since I come from a drinking family, I used to not like drinkers in general.”

-----Was it your father who was the drinker in your house?

“Yes.”

-----Did his drinking make your mother feel troubled?

“Yes. He didn’t become physically violent when he got drunk. But my mom was frequently quite annoyed since he often went out with his drinking friends and didn’t come back until very late.”

Husband’s drinking habit

-----Does your husband have a drinking problem or alcohol dependence syndrome?

“I don’t think so. His blood sugar level is indeed high. The doctor diagnosed him as hyperlipidemia, diabetes, urisemia, but not alcohol dependence syndrome. Also, there is nothing else he can do besides drinking... When I say to him, ‘Don’t you think you should stop drinking? [indirectly and subtle]’ he yells at me, ‘If you take alcohol away from me, what else could I do!’ Whatever I say, it is of no use. And, as I said before, I am a person who follows his words; he is doing whatever he wants to do. You see...contrary to me, he has an unyielding character...”

-----Do you think he drinks too much?

“Well I think he drinks a lot, but I don’t think he drinks too much.”

-----Didn’t the doctor advice him to abstain, though?

“Well...what shall I say to this word.... Well, indeed, his blood sugar level once went up to 280. But I must let you know about the reason for this. He was mixing *shochu* [Japanese distilled liquor, see glossary on page 557] and wine and drinking it everyday for about a month. And it is such a drinking pattern that boosted up his blood sugar level to this extent at once. When the doctor told him to abstain, he stopped drinking for a month and the number went down quite a bit. Well, afterwards, with the idea that drinking just a little bit is okay, he started drinking again... and he became incapable of abstaining again....and here he is now drinking the way he is right now.”

-----So are you saying that he doesn't drink as much as he used to any more?

“Yes. It didn't increase for sure. Compared to the days when he drank the most, it is a lot less now...definitely. It seems like he has his own rule for how much he is allowed to drink per day, too.”

-----Could you tell me how much he used to drink when he drank a lot and how much he is drinking right now?

“Honestly speaking, I don't really know. For when he drank a lot...I think it was when he was in his 30s. One day, he emptied a bottle of *Daruma* whiskey (very popular whisky. It comes in 700 ml [≈ 0.18 gallon] and 1400 ml [≈ 0.37 gallon] bottle and is moderately priced.) in a day with his friend. These days, he drinks 3 glasses of *shochu* with hot water every day. He likes drinking while watching television in the *kotatsu* [Japanese winter table. A table with a built-in electric

heater and a quilt over it.] Sometimes, he drinks and ends up sleeping in the *kotatsu* and when he wakes up—about 2-3 hours later—he drinks again.”

-----Do you know how much alcoholic beverages you buy per week or per month...or something like that?

“Right now, we are buying 6 bottles of *Daigorou* (*shouchu*, this often comes in 2.7 liter [≈ 0.71 gallon] bottle and is very cheap.) at *Yamaya* [a cheap liquor shop in the region] every month. I put them in a 750 ml bottles and serve it to him. Since I can’t drive, my husband drives me there to buy the alcohol. Sometimes the 6 bottles do not last a month. By the way, 6 bottles is not only for him. My son and daughters drink it when they visit us, too. Well, everyone has a different taste for alcohol so usually different kind drinks are prepared for everyone in our house.”

Fumiko’s drinking habit

-----By the way, do you drink, too?

“Yes. I drink about a glass of *shochu* with water before going to bed. When it is not enough, I sometimes drink a little more.”

-----Do you drink because you have trouble sleeping?³⁶

“No, I don’t have that problem at all. I can sleep anywhere at anytime.”

***Banshaku* [drink with meal, see glossary in p-?] without a meal**

-----Do you do your bedtime drink with your husband?

“No, I do this without my husband. He drinks before the meal. I don’t drink with him in general.”

-----Your husband is a *banshaku* [drink with meal] drinker, too?

“Yeah....well...he drinks before the meal.”

-----Drinks and then eats...

“Well, it doesn’t necessarily mean that he eats afterwards.”

-----Wait. Let me clarify. He drinks and then eats, right?

“Well I serve the meal with drinks but he doesn’t eat.”

-----You mean he doesn’t eat at all, even the relish?

“He eats relish dish just a little bit, but he mostly doesn’t eat at all. Even when I serve a meat or a fish dish, he doesn’t eat even a small piece.”

³⁶ According to statistics, many Japanese drink before going to bed because they have sleeping disorder. (Cite)

-----And that is it? How about staples? Does he eat rice at all?

“No, he doesn’t eat rice at all. And yes, that is it. That’s all he eats.”

-----Could you tell me about your husband’s daily eating habit?

“In the morning, he eats breakfast. He doesn’t drink alcohol here. In the afternoon, he eats lunch. For lunch, we often have a noodle dish. For this, too, he doesn’t drink alcohol. Then comes dinner. He drinks before dinner and eats just a very small bit of the dish, the relish, and that is it. [Fumiko paused.] Because of this, I try to include as much meat and vegetables in his lunch as possible.”

Husband’s drinking habit

-----Has your husband ever had alcohol related problems?

“No, I don’t think so.”

-----Has he ever missed work because of a hangover?

“No, that kind of thing didn’t happen. As I said, he was a very serious person when it came to work.”

-----That probably means that you didn't need to call his workplace to tell his boss that he is not going to work on that day. What about cleaning up other kinds of messes though? Have you ever received a call from a bar saying your husband is drunk so please come and pick him up?

“No, not really. But, when he drinks outside, it seems like the tension all goes away by the time he arrives home. There were occasions when I found him lying on the entrance room's floor because he was drunk and I had to take him to the bedroom. There was one time at the end-of-year party when he was drunk and slept at the neighborhood's bus station, too.”

-----How about alcohol related traffic accidents? Has he ever been caught because he drove under the influence of alcohol?

“No, that never happened. The reason why he drinks at home is because he doesn't want to drive under the influence.”

-----How about violence? Has he ever resorted to violence when he was drunk?

“No, that never happened either. There is no fight between us as well.”

-----Does he become too talkative which annoys you?

“Oh yes, very. He says the same thing over and over again.”

-----Does he reiterate the same thing every time when he drinks, or does he reiterate a matter that concerns him at that moment?

“He mainly talks about things he carries in his mind at the moment he is drinking. But he does talk about the same thing—complains about the current situation by comparing it to the things in the past—over and over again, too.”

-----Does he complain about you or to you while he is drunk?

“No. Not really.”

-----Hmm. How do you feel when he is drinking? Are you careful with your words or behaviors to not make him upset?

“Yes. I admit there is that aspect. As you said, I am careful not to say things that he doesn’t want to hear or something that may make him feel bad when he is drinking. This is something I have been practicing for a long time.”

-----While he is drinking, do you say to him something like ‘Didn’t you have enough for today?’
[≈Why don’t you stop drinking?]

“Never! [Fumiko said this with determined tone.] I always say such a thing when he is not drunk, that is when he is sober *and* calm. When I advice him when he is sober, there is a chance that he will listen and even say ‘Yeah, maybe...’ if I am lucky.”

-----By the way, do you think that your husband is a problematic drinker?

“No, I do not think that there is especially a problem. But that might just be because I am good at adjusting to him. You see...as I said...I am a *ki-ga-yowai* [≈unconfident and timorous] person.”

Reasons for husband’s drinking

-----Why do you feel your husband drinks that much? Tell me what you think besides the reason “he likes drinking.”

“The reason for his drinking? I have never thought about such a thing. So...I really don’t know.”

-----Has he ever grumbled about his workplace while drinking?

“No. He wasn’t a person who brought work-related stress back home.”

-----Was his father also a drinker?

“I don’t know. My husband’s father died in a traffic accident when Ichiro was four years old.”

-----Do you think this experience is related to the cause of his drinking?

“Hmm...I don’t know. I’m sure it influenced his character, though.”

-----By the way, did you have problems with your mother-in-law?

“It will be a lie if I say I didn’t. But since I follow other people’s words without any complaints, it wasn’t that bad. Since my mother-in-law was a meticulous person, like her son, she expected me to do many things such as housework in the way she does. As I am not as meticulous as her, it was quite a tough time. [Fumiko paused.] But, as I said, I keep things inside. Well, but there was one time when I exploded and quarreled with her loudly.”

-----That must have been fearful for your mother-in-law since you are not the type of person who shows anger. I bet your family members got surprised too, didn’t they?

“Yes. At that time, my mother-in-law gave in.”

-----Do you think your husband drank because he was in a difficult position with this wife and mother-in-law problem?

“I don’t think so. In general, I try not to grumble about my mother-in-law in front of my husband. In the past, when I happened to complain about his mother, he looked very upset, which made me think I should never say such a thing to him. So since then, I haven’t talked badly of her in front of him at all.”

Through the interview, what was remarkable was Fumiko's character. I am sure there are occasions where she feels disappointment and anger just like anybody else. What is noteworthy is her ability to behave like she is not feeling such negative feelings. Because of her kind-looking appearance and her slow way of talking, she does give the impression that people may take advantage of her by behaving selfishly. I think all this however really comes from her very kind and caring intentions which makes her repress herself quite a bit. For example, she did not talk much. She never went beyond the border when she expressed her feelings about her husband and her mother-in-law. From a certain traditional perspective, she has the ideal attitude of a Japanese wife. From my perspective, however, such a character contributes to the situation where the husband's drinking problems are hard to recognize in society. I also think that such cases—where the wives' obedient and understanding character makes it difficult to notice her husband's drinking problem—exist a lot more than we imagine in Japanese society.

Case 19. My current husband is a quiet person. Since he becomes talkative when he drinks, I drank together with him to communicate with one another. (Wife: abstaining, husband: drinking)

Name		Age	Occupation											
Yumiko Miura		56	Salesclerk at a department store											
Family			Husband's Occupation											
<input checked="" type="checkbox"/> Nuclear	Extended	# of members	3	Salesman at a department in a department store dealing with large institutional customers										
Family members														
Jiro	Husband	45												
Yumiko	Wife	56	Menopausal disorders. Advised by a doctor to reduce her drinking.											
Kazuo	First son													
Total Interview Time		Husband Attending Self-help Group?		Wife Attending Self-help Group?										
1 hour 30 minutes		Yes <input checked="" type="checkbox"/> No		Yes <input checked="" type="checkbox"/> No										
Wife's KAST concerning her husband's alcohol related behavior (See Appendix 1 on Page 546)														
1	2	3	4	5	6	7	8	9	10	11	12	13	14	Total
3.7	<input checked="" type="checkbox"/> 3.2	<input checked="" type="checkbox"/> 2.3	<input checked="" type="checkbox"/> 2.2	<input checked="" type="checkbox"/> 2.1	<input checked="" type="checkbox"/> 1.7	1.5	1.2	0.8	<input checked="" type="checkbox"/> 0.7	0.7	0.6	0.5	0.5	≈10.2
<input checked="" type="checkbox"/> 1.1	-1.1	-0.8	-0.7	-0.7	-0.4	<input checked="" type="checkbox"/> 0.5	-0.2	<input checked="" type="checkbox"/> 0.2	0	<input checked="" type="checkbox"/> 0.1	<input checked="" type="checkbox"/> 0.1	<input checked="" type="checkbox"/> 0	<input checked="" type="checkbox"/> 0	
?	?	?	?	?	?	?	<input checked="" type="checkbox"/> ?	?	?	?	?	?	?	
Analysis (See Analysis on Page 489)														
<input checked="" type="checkbox"/> A1	<input checked="" type="checkbox"/> A2	A3	<input checked="" type="checkbox"/> A4	<input checked="" type="checkbox"/> A5	<input checked="" type="checkbox"/> A6	<input checked="" type="checkbox"/> A7	<input checked="" type="checkbox"/> A1	A2	<input checked="" type="checkbox"/> A3	A4	A5	A6	G1	
<input checked="" type="checkbox"/> C1	<input checked="" type="checkbox"/> C2	<input checked="" type="checkbox"/> C3	<input checked="" type="checkbox"/> C4	<input checked="" type="checkbox"/> C5	<input checked="" type="checkbox"/> C6	<input checked="" type="checkbox"/> C7	D1	D2	D3	D4	<input checked="" type="checkbox"/> D5	<input checked="" type="checkbox"/> D6	<input checked="" type="checkbox"/> D7	<input checked="" type="checkbox"/> D8
E1	<input checked="" type="checkbox"/> E2	E3	E4				<input checked="" type="checkbox"/> F1	<input checked="" type="checkbox"/> H1	H2	H3	<input checked="" type="checkbox"/> H4	H5	<input checked="" type="checkbox"/> H6	
Types of Problems (See Analysis on Page 489)														
<input checked="" type="checkbox"/> Verbal Abuse	Physical Abuse	Financial	<input checked="" type="checkbox"/> Psychological	Shirinugui	<input checked="" type="checkbox"/> Child-Related									
Note														

Yumiko Miura

My impression of Yumiko was more than just a “kind/nice” person; she was rather a type of person whom one may take advantage of.

“If I see somebody in trouble, I can't stand still. I feel like I have to do something for that person.”

As it will be described in this dissertation, although she experienced horrible incidents not through her own fault, she says she never felt hatred against the wrongdoers.

Abstinence

In addition to her husband, Yumiko is also a drinker. Since her definition of “alcoholics” is “excessive drinkers who cause alcohol related trouble to others,” she does not consider herself as being an alcoholic. For the same reason, she does not regard her husband as an alcoholic either. Because of this, both Yumiko and her husband Jiro do not attend any self-help group meetings. Her own and her husband’s excessive drinking habits, however, have been pointed out to them by their physician. Yumiko describes her doctor’s advice and her current drinking habit as follows:

“Since I was told by my physician to reduce drinking and smoking, I have been abstaining for a while. These days, I quit smoking, too. Since then, my coughing and phlegm problems deceased. The neutral fat decreased, too. I am in a much better condition now. [Yumiko pauses] But, perhaps it’s menopausal disorder [She is 56 years old now]...these days I

have shoulder and backache problems. One day when I was walking outside, the whole world suddenly spun around me. I trembled. I couldn't stand still. That was a scary moment. I consulted my doctor about my problem, but no drastic change has been made so far."

Yumiko's and her husband's drinking habits

-----So, you were a drinker, too?

"Yes, a long time ago. My current husband drinks every day since before he re-married. Since I joined him in his every day *banshaku* [drinking with meal, see glossary on page 554], I started to drink habitually, too. Since my former husband didn't drink, I didn't use to drink either."

-----So you happily drank together as part of daily *banshaku*?

"Yes. My current husband is a quiet person. Since he becomes talkative when he drinks, I drank together with him to better our communication. [Yumiko paused.] But, Jiro has a bad drunken habit. He's not *shuran* [frenzy drinker] per se. But he can't stop drinking when he should and therefore he frequently keeps drinking until he becomes dead drunk. He also becomes verbally abusive; he says things that he usually doesn't say when he is sober. And when that happens, I respond to it which leads to hours of quarrel. I hate this very much."

-----What do you mean by "saying things that he usually doesn't say when he is sober"?

“Well [Yumiko looked as she was thinking.] Things that he doesn’t say when he is sober... [Yumiko repeated my words looked as she was thinking hard.] For example, when all the relatives gather for a family reunion, his older brother says things like ‘You [=the brother’s wife] don’t keep good relations with my relatives.’ in front of everyone. There is no need to say such a thing at that moment especially in front of people. My husband is like that, too. When we have visitors, he complains that I talk too much on the phone or I don’t take care of the family’s grave—things that are not necessary to say—in front of people. When he is drunk, he also talks about things that he is not happy about in his life in general. He once said, ‘I can’t stand you making fun of me just because I am younger than you!’ I never thought in that way, so I was surprised when I heard this.”

-----Does he pick a quarrel with his son as well?

“No, that doesn’t happen. But his son is not happy to see his father being dead drunk all the time.”

-----Does he resort to violence when he is drunk?

“Oh, no. That kind of thing rarely happens.”

-----By the way, how much does your husband drink in general?

“My husband is [biologically] weak against alcohol. He only drinks two to four cans of beer per day, but only that will make him dead drunk. He can’t control himself. He drinks every day. On weekends, he drinks from the morning.”

-----How about you? Do you lose control like your husband?

“No. Contrary to Jiro, I don’t lose control like him no matter how much I drink. I don’t grumble like him nor lose my mind like him, either. Even if I drink one *shou* [≈ 1.8 liter ≈ 0.48 U.S. gallon] of *sake*, I am still fine. In fact, my parents welcome me with two *shou* of local sake every time I go back home. The first *shou* gets emptied immediately without any problem. As I said, I am abstaining right now. I don’t drink like that anymore.”

Marriage history

(1) The former husband

-----It seems like you have married twice. May I ask the reason why you got divorced with your ex-husband?

“My ex-husband had gambling and debt problems. He gambled and borrowed money, again and again.”

-----How did you meet and marry him?

“I was raped by him. I became *kizumono* [broken commodity] so that marrying him was unavoidable. I had a boyfriend at that time, and my ex-husband was an acquaintance of my boyfriend.”

----- [I was lost for words.] Was marrying the rapist the right thing for you to do, though?

“I don’t think it was right. I was very sorry for my boyfriend, too.”

-----Did you have any child between you and your ex-husband?

“Yes. But the children stayed with him after the divorce.”

-----It’s common for the mother to keep the child, but not in your case. Is there any particular reason why he kept the child?

“When we got divorced, my children were already grown adults. The oldest daughter had only a few more years until her wedding. Therefore, I said to my ex-husband, ‘Do something for them as their father at least for the last year.’ and left the kids to him.”

According to Yumiko, the relationships between the children and her are currently satisfactory. She was planning to visit one of the daughters after the interview, too.

-----Did the separation between you and your children cause you stress and consequently lead you to drink?

“I don’t think so.”

She seemed bewildered by the question, which made me feel that it was irrelevant. Yumiko says that although the second daughter went through juvenile delinquency during her junior high school time, the children are both married and living happily with their own families.

-----Do you hate your ex-husband for screwing up your life?

“No I don’t bear any grudge against him. I’ve never hated someone in my life in the first place. The child is also not sinful, either. In fact, I am even thankful to my ex-husband.”

-----Thankful? For what?

“Well, because he taught me how to use money.”

-----Hmm.

(2) The current husband

Yumiko’s current husband, Jiro, has been married once before, as well. He lost his wife because of sickness, and had a son [Kazuo] with her. When he lost his wife, his relatives

worried about him managing the domestic and outside work. Through the relatives, Yumiko was introduced to Jiro and they married each other for the sake of “mutual necessity.” At that time Yumiko was forty-three and Jiro thirty-two years old.

Jiro was not a problem-free husband either. He was flirtatious. [He already had this problem in his former marriage.] Yumiko paid several hundred thousand yen [≈ several thousand U.S. dollars] to one of the women as consolation money. [According to Yumiko, this woman asked for additional money because of her mother’s illness.]

“Since the consolation money, his affairs stopped. [Yumiko laughed.] Since he lost his father when he was young, he grew up in financially difficult circumstances. Because of this, he is quite strict about money. Anyway, therefore, he was quite shocked when he had to pay the money. He was very sorry for what he had done. [Yumiko laughed.] So, recently, he participated in a work-related reception, and things were set up for an affair. Female escorts were invited to the party and futon beds were prepared for two people in a room. When he saw the room, he had a stomachache and wanted to throw up. He told me that he became scared immediately and wanted to run away from there. [Yumiko laughed.]”

Yumiko’s wish

-----Do you have any wish regarding your husband’s drinking?

“I wish he wouldn’t drink too much.”

-----Is that because as long as he’s not drinking, he is all right?

“No. I am saying he is all right if he doesn’t drink too much.”

Because of her careful wording, I laughed involuntary. He is generally a good person. He is a good person when he drinks, too. It becomes a problem only when he drinks too much, and that is what Yumiko is discontent about.

The reasons for Jiro’s drinking

-----Why do you think your husband drank so much?

“I think the primary reason is because of his blood. He loves alcohol from the heart [=He was born in that way].”

----- Do Jiro’s family members also drink?

“Yes. His siblings are all *nonbei* [≈boozer]”

-----How about his father? Was he also a drinker?

“I don’t know. Since Jiro’s father died when Jiro was still little, I haven’t heard much about him.”

----- Are there any other possible reasons for Jiro’s drinking?

“Sometimes I think he is a so-called the ‘*samishigariya* [someone who cannot stand loneliness].’ This is something I noticed when he had to quit his previous workplace [his company went bankrupt] and started to have more time at home. I thought, ‘He may be a person who cannot be alone.’ He couldn’t stand not drinking with me, with his friends, or with his workmates. He is not good at spending his time by himself. I think this is related to his drinking habit. [Yumiko paused.] Also, I think his work environment was also related to his drinking habit. Because he was a salesman who deals with large institutional customers, drinking such as in *settai* [business related reception, see glossary on page 556.] was part of his work. Before leaving this job, almost every other evening was spent drinking outside with his customers and colleagues. In addition to this, he often organized drink related business at his workplace. He was frequently appointed as the *enkai-buchou* [chief for managing the party]. When he gets appointed to this, the party tends to go well. It seems he likes doing this kind of stuff a lot, too.”

Outside drinking behavior

Contrary to his deadly drunk behavior at home, Jiro drinks responsibly outside. For example, he never loses control when he drinks outside. Yumiko has never been called by the police nor by the bar staff because of his alcohol related problems. [He fell down twice while using the toilet at his house, though.]

“He always returns responsibly by himself after the drinking parties. But perhaps his tension goes away when he arrives home. There are frequent occasions when he lacks the memory of anything after his arrival home by taxi after the party.”

-----Does he miss work because of a hangover?

“Never! The next day, even when he has a hangover, he never misses work. He is a hard working man who goes to work even if he has forty degree [40 Celsius =104 Fahrenheit] fever.”

The stepson

I asked Yumiko regarding several possible hypotheses for the cause of her husband’s drinking.

-----Was there any relationship problem between you and your stepson?

“Yes we had a problem for a long time. We have somewhat solved this problem, though. Kazuo didn’t listen to me since he hated me. For example, when I told him to use chopsticks during the meal time, he intentionally grabbed the food with his hands and ate. One time, there was a big jar of pickles in our house. Since it was very salty, I told him not to eat too much. However, on the same day, I found the jar empty. There was also a day when we received five boxes of cookies. He ate most of them on a day. At night, he was vomiting the cookies again. He had quite a twisted character.”

-----That's sad...

“He lied all the time. He didn't open his heart to me at all. But, one summer day when he was in ninth grade, I confronted him and asked, ‘Why are you never listening to me?’ Then he responded, ‘You are not my real mother, and that is why.’ This was like the reconciliation between us. Many things became a lot better afterwards.”

-----Do you think the bad relationship between you two caused Jiro stress, which consequently became the cause of his drinking?

“Hmm [Yumiko looked as she was thinking]. Maybe, but maybe not. I don't know. One thing I can say is that, as I told you, Jiro and I were drinking together. Recalling those occasions, I don't think he was drinking because he was dissatisfied about my bad relationship with his son, nor drinking because he wanted to escape from the harsh reality.”

Enhancing one's masculinity

A long time ago, an alcoholic, also a womanizer, told me that his reason for his excessive drinking was “to enhance his masculinity.” Since Yumiko's husband also seemed to like women, I asked about this being a reason for his drinking.

“‘Drinking to enhance his masculinity?’ I don't think so [Yumiko bursts out laughing]. As I said before, he is a quiet person. He drinks responsibly outside the house, too.”

Problem with the mother-in-law

-----Do you have problems with your mother-in-law?

“With my ex-husband, I did. My ex-mother-in-law was quite a mean person. But now, with my present husband, we have almost no problem with her. I must mention, however, that Jiro’s oldest brother’s wife has considerable trouble with her mother-in-law. It seems like those two don’t get along at all. Sometimes, our mother-in-law visits our house and stays for over a month, which is almost like running away from her house. And every time she comes, she speaks quite ill of my husband’s brother’s wife. Since she says bad things about her, she must be talking ill about me to other people, too. I try, as much as possible, not to get involved in her game. Anyway, the relationship between the mother-in-law and the oldest son’s wife is quite difficult in that house. I heard that the mother-in-law even attempted suicide by cutting her wrist with a knife.”

-----Is it possible that the oldest brother is caught up in this problem, increasing his stress, and consequently leading him to drink excessively?

“Well, I know he is quite troubled as the intermediary between the two. I also know that he drinks a lot. However, I’m not sure if his drinking problem is caused by the bad relationship between his wife and his mother.”

Yumiko's family background

Yumiko grew up in a relatively wealthy family. Her father was a politician. Her parents were very strict with their children. There is no alcoholic in the family. According to Yumiko, they had no family malfunction problem, either. Although her oldest brother lost all the family property due to repeated debts for his business, all Yumiko's siblings have serious characters and are hard-workers, including the oldest brother. Because of her brother's debts, Yumiko had to quit university which she was attending for a year. Yumiko does not complain about this, at all.

“I don't care much about that. I have no hatred against my brother nor any negative feelings about that time either.”

Since I have witnessed many families where the relations are cut because of the family property, Yumiko appeared to me to be “very lenient.” I was curious to know the root of that character, but exploring it through just this interview was not possible.

According to an acquaintance of Yumiko, an active member of a self-help group, who introduced me to Yumiko, Yumiko's husband is clearly an alcoholic. But on the other hand, Yumiko does not see her husband as a seriously problematic drinker. She certainly does not seem to be desperate for help because of her husband's drinking. Perhaps, her optimistic character, her not-thinking-too-much or her tolerance are related to her unawareness of the problem.

Case 20. Only Tokiko - forever

Name		Age		Occupation											
Tokiko Tsuda		54		Housewife (part-time worker when living separately from husband)											
Family							Husband's Occupation								
Nuclear <input checked="" type="checkbox"/> Extended		# of members		7		Salesman at a Japanese major enterprise									
Family members															
Ichiro		Husband		54		Diagnosed with alcohol dependency syndrome.									
Tokiko		Wife		54											
Kazuo		First son		32											
Tsugio		Second son		26											
Mitsue		First daughter		22											
Ichi		Tokiko's father		Bedridden											
Ichi's wife		Tokiko's mother													
Total Interview Time				Wife Attending Self-help Group?				Husband Attending Self-help Group?							
4 hour 30 minutes				<input checked="" type="checkbox"/> Yes No				<input checked="" type="checkbox"/> Yes No							
Wife's KAST concerning her husband's alcohol related behavior (See Appendix 1 on Page 546)															
1	2	3	4	5	6	7	8	9	10	11	12	13	14	Total	
<input checked="" type="checkbox"/> 3.7	<input checked="" type="checkbox"/> 3.2	<input checked="" type="checkbox"/> 2.3	<input checked="" type="checkbox"/> 2.2	<input checked="" type="checkbox"/> 2.1	<input checked="" type="checkbox"/> 1.7	<input checked="" type="checkbox"/> 1.5	<input checked="" type="checkbox"/> 1.2	<input checked="" type="checkbox"/> 0.8	<input checked="" type="checkbox"/> 0.7	<input checked="" type="checkbox"/> 0.7	<input checked="" type="checkbox"/> 0.6	<input checked="" type="checkbox"/> 0.5	<input checked="" type="checkbox"/> 0.5	21.7	
-1.1	-1.1	-0.8	-0.7	-0.7	-0.4	-0.5	-0.2	-0.2	0	-0.1	-0.1	0	0		
?	?	?	?	?	?	?	?	?	?	?	?	?	?		
Analysis (See Analysis on Page 489)															
<input checked="" type="checkbox"/> A1	<input checked="" type="checkbox"/> A2	A3	<input checked="" type="checkbox"/> A4	<input checked="" type="checkbox"/> A5	<input checked="" type="checkbox"/> A6	<input checked="" type="checkbox"/> A7	<input checked="" type="checkbox"/> B1	<input checked="" type="checkbox"/> B2	<input checked="" type="checkbox"/> B3	<input checked="" type="checkbox"/> B4	B5	<input checked="" type="checkbox"/> B6	G1		
<input checked="" type="checkbox"/> C1	<input checked="" type="checkbox"/> C2	C3	<input checked="" type="checkbox"/> C4	<input checked="" type="checkbox"/> C5	<input checked="" type="checkbox"/> C6	<input checked="" type="checkbox"/> C7	D1	D2	<input checked="" type="checkbox"/> D3	D4	D5	<input checked="" type="checkbox"/> D6	D7	D8	
<input checked="" type="checkbox"/> E1	<input checked="" type="checkbox"/> E2	E3	<input checked="" type="checkbox"/> E4				<input checked="" type="checkbox"/> F1			<input checked="" type="checkbox"/> H1	<input checked="" type="checkbox"/> H2	H3	<input checked="" type="checkbox"/> H4	<input checked="" type="checkbox"/> H5	H6
Types of Problems (See Analysis on Page 489)															
<input checked="" type="checkbox"/> Verbal Abuse		<input checked="" type="checkbox"/> Physical Abuse		Financial			<input checked="" type="checkbox"/> Psychological		<input checked="" type="checkbox"/> Shirinugui			Child-Related			
Note															
Ichiro's mother deceased 2 weeks before the interview took place.															

Tokiko Tsuda

Tokiko went through many difficulties [e.g. mother-in-law problems, husband's drinking problem] which were beyond her control. However, she never quit; she always made the best out of the situation when she confronted problems.

Marriage for love

-----How did you get to know Ichiro, and later marry him?

“We married for love. Ichiro and I were junior high school classmates. When I became a high-school student, I received a letter from him saying that he wants to become associated with me. It seems like he had been thinking of me since he was in junior high school. With this, our relationship started.”

-----That's unusual [for a junior high-school relationship to develop into a marriage]!

“Since cell-phones and pagers were not available at that time, we often exchanged letters. He was a very good correspondent. He definitely wrote more than me. I, however, burned all his letters when we started to live separately. Now I regret it, but, at that time, it was unavoidable.”

----- I wasn't aware that couples of those days wrote to each other as the means of communication. How nice that your boyfriend wrote so much!

“Well, in fact, it wasn't that nice. He wrote much about his bottled-up feelings that I didn't care about. It's okay to write things like 'I love you.' But his letters were shilly-shally, melancholic

and/or unmanly. I don't like this kind of difficult people. So, because of this, I ended our relationship after all. For a while, he kept sending me letters. But as time went by, the letters stopped, and so did our relationship.”

-----Oh, you broke up? [I felt it was unexpected.]

“After we broke up, I spent my exciting girls' time with my school friends. We went to movies, coffee shops etc. I did this until I became a second year college student, that is when I was 18 years old. Then, one day on New Year's Day, I met Ichiro at the local shrine's festival by chance. It was me who approached him: I said to him, 'Ichiro! Long time no see!' Alas! If only I hadn't talked to him at that time! If only I had ignored the situation and just passed by!!! [Tokiko pauses.] This restarted our relationship. I remember we went to the coming-of-age ceremony together. And on that occasion, he proposed me, to which I somehow nodded. I was only twenty years old at that time. When I look back, I think it was too early to get married.”

Husband's drinking habit before marriage

-----Did your husband have any alcohol related problem before your wedding?

“Ichiro's drinking problems started after he started to work for the company's sale's division. Since he didn't drink at all until then, I never had a problem with his drinking behavior.”

Bad relationship between grandmother [mother-in-law] and great-grandmother [grandmother-in-law]

Tokiko married in to a family with an only son. The new family consisted of five people: Tokiko's grandmother-in-law [Ichiro's father's mother], parents-in-law [Ichiro's parents], Ichiro and Tokiko. Since Tokiko's father-in-law was a business bachelor living far away from the family, only four of them were actually living together in the house. Since Ichiro and his mother worked outside the house, Tokiko spend a lot of her day-time with her-grandmother-in-law.

“My grandmother-in-law was a Meiji-born-woman, who was perhaps braver and stronger than average Meiji women [women born in the Meiji period are said to be strong in Japan]. Although she was respectable in general, she disliked my mother-in-law, or her daughter-in-law. Those two were finding faults in each other every day. Occasionally they glared at each other or one explodes and yelled at the other one. The extension to this was my grandmother-in-law talking bad about my mother-in-law to me all the time. Thinking back, I should have asked my grandmother-in-law to cut it off by saying, ‘please do not talk about these things.’ Often, I was quiet, bearing the situation of listening to great-grandmother's gripes. [Tokiko paused.] At that time, I frequently visited my parent's house which was located in our neighborhood. I told my mother about my grandmother-in-law's gripes. My mom listened and advised me to keep them [these problems] within our families. Sometimes, my grandmother-in-law came to my parent's house and spoke badly of her daughter-in-law, too. My mother and I were always the audience. We thought that as long as we listened to her bottled-up feelings and kept them secret, it would be fine.”

Tokiko was not only a good audience for her grandmother-in-law; she was also an audience for her mother-in-law who spoke bad of her mother-in-law.

-----What was the position of your father-in-law [Ichiro's father]? Was he on your mother-in-law's side, or was he on grandmother-in-law's side?

“He wasn't on either side. As I said, he was a business bachelor who wasn't in the house. Well, but if I have to pick one, I would say that he was rather on the grandmother-in-law's side.”

-----There are cases of the child being involved in the wife and mother-in-law problem as a wife's ally. Did this happen to Ichiro, too?

“Rather than being my mother-in-law's ally, Ichiro was *obaachankko* [grandmother's child, a child who feels close to his grandmother] and therefore was on my grandmother-in-law's side. By the way, Ichiro's unmanly nagging and fussy character all come from this grandmother-in-law.”

Tokiko regards her position as being rather on her grandmother-in-law's side as well. In those days, there were factions within the household [grandmother-in-law vs. mother-in-law], which Tokiko thinks was unhealthy for the family.

-----Were you in bad with your mother-in-law or great-grandmother?

“Surprisingly, I wasn't. Well, I had a fight with my mother-in-law once which led me to leave the house, though.” [This part will be described later.]

Mother-in-law (Part 1)

-----If you and your father-in-law were siding with your grandmother-in-law, it seems as there was nobody siding with your mother-in-law. Who was your mother-in-law's consultant?

“Well, I don't know. Maybe it was her husband [my father-in-law].

-----I see. [But, according to Tokiko he was rather on the grandmother-in-law's side.] What kind of person was your mother-in-law?

“She was a very dependant person. She also had an unyielding spirit. She wasn't a domestic woman; she especially hated cooking and doing the laundry. But on the other hand, she was obsessed by cleaning the house; she was especially crazy about wiping floors and walls.”

-----Was she an introvert person or out-going person?

“She was an out-going person.”

Grandmother-in-law

-----What kind of person was you grandmother-in-law?

“She was a respectable person. She had an unyielding sprit as well. She was also a person who regarded herself as more perfect than anybody else around her. She believed that she and her children, especially her son, are 100% perfect and therefore very different and special from other

people. When she encountered people, she also had the habit of finding fault in them, no matter how wonderful the person was.”

-----Was your husband also the 100% perfect person, according to your grandmother-in-law?

“No, he wasn’t. She said this was because of my mother-in-law’s family [Tokiko pointed to the mother-in-law’s lineage on the kinship chart]. My grandmother-in-law was a person who often blamed Ichiro’s bad habits on my mother-in-law or mother-in-law’s family.”

-----Where does this great-grandmother’s strong confidence come from?

“Well, she is *ie-musume* [She did not move into her husband’s house upon her marriage; it was rather her husband who move into her house.] who was adopted by her adoptive parents who had three other girls. She was so-to-speak the chosen one among the four daughters and inherited her adoptive parents’ property.”

-----She must have been very reliable, and maybe that is the reason why she was chosen.

“I guess that is right.”

Husband’s drinking habit at the time of Tokiko’s wedding

-----Tell me about your husband’s drinking at the time of your wedding.

“He was working at the sales division at T-company [big enterprise]. Until then, he was a person who didn’t have any association with alcohol at all. He had to drink outside as part of his work, which eventually made him acquire a taste for alcohol. Every year, his way of drinking - drink and cause trouble - worsened. He drank in a troublesome manner: he destroyed the entrance door, fell over and got injured, became so dead drunk that I had to pick him up at the bar.”

-----Is he *shuran* [a person who becomes frenzied when drunk]?

“Well, it’s hard to answer this question. Although he becomes violent, he is rather a person who accuses himself when he becomes drunk. In addition, when he was violent, he never used violence against me but against his mother. The target of his violence was always my mother-in-law—his mother. Sometimes he pointed the kitchen knife at her. She was often frightened and hid all the kitchen knives in the house. When he became violent, she called me or my parents for help. Sometimes, while I was in the midst of holding down my rampaging husband, my mother rushed over to our place and helped us. She came with a flashlight in her hand since this always happened in the middle of the night. Sometimes I stood astride Ichiro while other people helped me holding him down.”

Mother-in-law (Part 2)

-----In general, in this kind of situation, isn’t it her other children, her own siblings, or husband’s siblings whom one would ask for help? Why did your mother-in-law call her daughter-in-law’s parents for help?

“Well, I don’t know.”

-----Were your mother-in-law's siblings living far away from the house?

“No. They were actually all living very close to the house.”

-----Hmm. Did your mother-in-law have any close siblings she could consult about her personal problems?

“She seems to have a sibling with whom she can talk. But she was not on good terms with her siblings in general. Just for your information, my mother-in-law's father was an alcoholic, too. As a part of my grandmother-in-law's blaming Ichiro's fault on my mother-in-law's family, his alcohol problem was also blamed on mother-in-law's family which included an alcoholic.”

-----Was he the type of alcoholic that caused trouble to his wife?

“Yes.”

-----Do you think your mother-in-law was brought up in a dysfunctional family?

“Yes.”

-----Do you think she had co-dependence [see glossary on page 554] problem?

“Yes, definitely.”

-----Is she aware of her co-dependence problem?

“No. She did not know at all. And without knowing she left this world. [Tokiko’s mother-in-law died 2 weeks ago.]”

Business related drinking

-----Where did your husband drink more often, outside or at home?

“He drank mostly outside. He came back after midnight almost every day. He often said ‘I will return home early today’ but he rarely followed his words; it was considered good if there was a day in the week when he returned early. As a member of the sale’s division of company T, he usually stayed home during the day and left home in the evening.”

-----Sometimes a worker is appointed to the sale’s division because he has the suitable character for being a Japanese salesman: sincere, polite and considerate for many small things even though he drinks a lot. Was your husband appointed to the sale’s division because he had this character?

“My husband certainly has knowledge about his company’s products and the ability to look up to the client even when he drinks. But, when he couldn’t sell off the products as he wanted, he often became frustrated and that suppressed feeling exploded at home when he came back. I therefore used to think that his work as a salesman was not a suitable occupation for him.”

-----When he drank outside, was he a ‘cheerful drinker’ or a ‘gloomy drinker’?

“He certainly was a cheerful drinker. When he was drinking, he kept talking and talking and people surrounding him had a hard time adjusting to his pace. He seemed as if he enjoyed the situation very much. It was pretty entertaining to see him, too.”

-----But once he returned home, he became violent, for instance pointing a knife at his mother, right?

“Yes, he changed. One day, for example, in the middle of the night, he came back drunk. In the house, he somehow became angry and threw a glass of milk against the ceiling as hard as he could. The children and I were miserable cleaning up the mess. During the time we were cleaning, I couldn’t believe it, but he was taking a bath! He often grumbled after his work, too. After he came back home, he didn’t let me go to sleep. We were in the bed, but he grumbled all through the night. I couldn’t go to sleep. No, that’s not the right expression. He made me listen to his gripes and I was not allowed to go to sleep.”

----- Did he continue to drink after he returned home?

“No, he didn’t.”

-----Your husband’s drunken behavior changes drastically from cheerful [while he is out] to quite abusive [at home]. And, strangely, these direct opposites are both induced by the same drug. Why do you think this happens?

“Well, I guess he is selfish. Perhaps his parents and grand-parents satisfied his *amae* too much. My grandmother-in-law was a person who didn’t allow men to enter the kitchen [≈she served well for men as a house-wife].”

----A long time ago, I interviewed male alcoholics who work in the sale’s division. During *settai* [business related reception] they are indeed entertained. But, moreover, I learned that their way of drinking is very stressful since they have to be considerate to entertain the guests. Could you see your husband’s cheerful drunk behavior in such a way?

“Well, yes. He certainly seemed as if he was having a good time when he was drinking outside. But if one asks whether or not that cheerfulness was coming from his heart, I doubt it was. It is possible that he was not really released. I think he was always making an effort to lighten the atmosphere for his clients.”

Ichiro, who was not fond of working in that division quit T-company and found a new job at S-company [also a big enterprise]. He is still working for this company.

T-company’s hard work ethics

-----Although T-company is considered one of the top competitive companies in Japan, I have heard that this company’s work ethics are inhumane and therefore extremely bad for the workers. Do you think that your husband’s impulsiveness is related to his work environment where he had to work under tremendous stress [e.g. reversed day and night cycle, required to suppress his ego as a salesman, pressured to reach his sale’s margin, sleeping throughout the day on Sunday]?

Tokiko looked as if she never considered Ichiro's impulsive character from this perspective. Saying "It is possible to think in that way," she did not deny my hypothesis. Our conversation changed topic after this and we did not expand on this point.

Moving out [first time]

After 6-7 years of marriage, Tokiko's nuclear family split from Ichiro's extended family.

"The cause of the separation was a fight between my mother-in-law and me. At that time, my parents were living in the next prefecture and were visiting our house occasionally. My mother-in-law extremely disliked visitors. I think it was because she mostly hated preparing the house, such as cleaning, cooking, preparing beds etc. Despite the fact that I had informed her of my parents' visit a long time in advance, my mother-in-law was complaining endlessly about my parents' visit on that day when they were coming. Her griping, in addition to my accumulated frustration caused by her in general, made me explode! I said with anger, 'Fine!' and declared defiantly, 'I am going to get out of here!'"

Tokiko continued.

"Contrary to my expectation, however, my mother-in-law's response was 'Okay, then why don't you leave?' This is the reason why I decided to leave the house. Afterwards, when I was packing my belongings, I noticed that I had lost my spine [Japanese expression for 'being too shocked that one becomes paralyzed']. I tried to stand up but I couldn't. I remember I was crawling in the room to pack my stuff."

----- Why was it so shocking?

“Contrary to my mother-in-law who didn’t put much importance in wife’s duty, I had always been making a lot of efforts to be a good married-in-wife in the house. I felt that this effort was betrayed. My mother-in-law’s words made me realize that she was not thinking highly of my daily efforts. No, that’s not exactly the right expression. I felt foolish, really foolish since I made much effort with a lot of patience and with a lot of time but then noticed that that effort was exactly for nothing.”

-----What was the position of your husband at that time?

“It seemed that he would also leave if I was leaving. Honestly speaking, I didn’t care about him at all. I just needed to get out of the house.”

-----Did your grandmother-in-law say anything to you at that time?

“No, she didn’t say anything.”

Tokiko’s nuclear family split from her husband’s extended family. This was the first of the several house-moving experiences.

Relationship between grandmother and great-grandmother

-----What happened to the mother-in-law and grandmother-in-law’s relationship afterwards?

Were they okay?

“As a matter of fact, I don’t know much about their relationship afterwards. I am sure that my father-in-law suffered a lot. My grandmother-in-law at the end was put into a nursing home despite her unwillingness to go there.”

Nuclear family life

Tokiko’s family started their new life as a nuclear family. Since she had been living under the constant surveillance of mother-in-law and grandmother-in-law, living life without that and being able to relax was by no means bad.

“Until then, I couldn’t relax even though it was my house. I felt bad for sleeping openly during the day. To take a nap, I usually took my baby to the bedroom, secretly locked the door, and dozed off with my sleeping child.”

Drinking together

Around that time, since Ichiro changed jobs and was no longer working in the sale’s division, his drinking problems settled down for a while.

“He still had some work-related drinking occasions such as the year-end-party and drinking with his colleagues after work, etc. He also drank at home. Sometimes he suddenly called me at home from a bar saying ‘I will come back with my subordinates so please be prepared.’ When he brought these friends, they continued to drink at home and some of them stayed overnight.”

Tokiko and Ichiro also drank together.

“From around this time, we started to drink together. I am not exactly an incapable drinker. Quantity-wise, I can perhaps drink more than him. Ichiro is, in fact, a physiologically weak drinker [incapable drinker]. [Tokiko paused.] When he came back from his work, we did *banshaku* [drinking with a meal, see glossary on page 554] together. Usually, we drank at home first. But, then, he often was unsatisfied with only drinking at home, and so he suggested to go to a bar in the neighborhood where we could entertain ourselves by singing *karaoke* and talking with other people, etc. When I didn’t want to go out, he went by himself. But, usually on such occasion, he called back home later from the bar and persuaded me to join him at the bar.”

-----That sounds like a lovely couple!

“No. As a matter of fact, it’s not good at all. When we went out, it was often me who ended up having a terrible time. When I drink, I almost never pass out but he does all the time. Usually I ended up carrying him on my back or giving him my shoulder to return home. Since this became our pattern, I always stubbornly refused when he asked me to go out.”

Husband leaving the house

The peaceful life did not last long. As the years passed, Ichiro’s drinking problems started again.

“He was drinking every day, literally 365 days a year. He drank all the time, so much so that he could not tell whether it was winter or summer. As long as he could drink every day, this kind of thing didn’t matter to him. He drank and grumbled, drank and grumbled. He griped against me, too. For example, he criticized my family in various respects. When I complained back, for

example saying just a bit about his family, his revenge was 100 times worse. Our relationship was bad, really bad. A lot of verbal fights. So, one day, our oldest son, who could no longer bear the situation, suggested us to live separately from one another. This was when our oldest son was 18 years old. Our family discussed about solving my bad relationship with Ichiro and after careful consideration about the budget, we decided that Ichiro would move out to his parents' place until his problem calmed down. He accepted the decision and left the house.”

Husband wants to return

Although Ichiro accepted to live separately from the family, he couldn't maintain living in that way as time passed.

“Although we lived separately from each other, he occasionally came to our house and we ate dinner together. Every time when he came, he said he wanted to come back and asked when he could move back in. [Tokiko paused.] I think he was lonely. From around this time, his drinking pattern changed. He was desperate; when he drank, he blamed himself and did crazy things.”

Ichiro was definitely desperate. He did not care whether his family wanted him back or not; he wanted to live with his family. The more desperate he became and the more forcible the means he used to return home, the more his family kept a distance from him. Eventually, they decided not to let Ichiro enter the house. Tokiko continued.

“He came to the house and pleaded again and again to open the door. But we didn't open the door under any circumstances. There was a time when our door was bloody around the doorknob. I suppose he got injured on his way there. It was obvious that he intentionally rubbed the blood on

the door. He did this sort of acting sometimes. There were also telephone attacks by him. He also caused trouble at the children's schools. He went there and in public begged the children for their permission to return home. The youngest daughter became the target of bullying where classmates made fun of her about this incident. Whatever means Ichiro used, however, I was determined not to let him return until he stopped drinking and became an ordinary person. So, I stubbornly denied his persistent request.”

-----Until he “stops drinking” and becomes an “ordinary” man....

“You see, I wasn't familiar with the concept of ‘alcohol dependence syndrome’ at that time. I believe it's not only me who is like this in this society. Not until I was told so by the doctor, I didn't know that his situation was the so-called ‘alcoholism.’ It would have been good if we were more informed about this disease, [the idea that this disease can happen to anybody, such as a white-collar worker like him]. Oh well. It's okay. Not all people need to know about this, if not necessary.”³⁷

First hospitalization

Around this time, Ichiro was hospitalized for three months at hospital A. Tokiko remained uninvolved in this event. Far from a sympathetic attitude, she was rather cool towards her husband.

³⁷ Tokiko uses the term “alcohol dependence syndrome” and “alcoholism” interchangeably. (The difference between alcohol dependence syndrome and alcoholism is explained in footnote 2 on page 1.)

“When I heard that he had entered the hospital, I thought, ‘Well, well...He finally reached the end; there is no more hope.’ Since I am a local here, I know that that hospital is not a normal hospital. [Tokiko paused.] At that time, I thought, ‘Don’t let him to out from that hospital. Please stay there forever.’”

Working outside

Also at this time, Tokiko started to work outside.

“I worked as a bar hostess. As a woman in her late thirties without any special qualification, I could find no job except for this.”

-----Did your husband know that you were working at a bar?

“Yes, he did.”

-----Didn’t he become jealous?

“Yes. During his phone-call attacks, his common words were: ‘I want to come back as soon as possible’; ‘I want to live with the family’; and ‘Don’t work at such a place.’”

-----Tell me your perspective as a person who suffers from your own husband’s drinking problems, but at the same time works for a business that sells alcohol to people like your husband.

“Well....By working there, I learned many things about people’s drunk behavior. There are various types of drinkers in this world. For some drunks, I did feel that their wives must be suffering badly from their drinking, just like I did. But for some drinkers, I thought they can drink quite a bit but never lose control. I noticed that there are also men who drink and get drunk but can still control their money. This was something Ichiro really lacked. I often compared customers’ drinking habits with my husband’s [Tokiko laughed]. Even though my job was to make people drink more, I sometimes cautioned customers who drank too much to stop their drinking and/or go home. [Tokiko laughed.]”

Injured from burning the car

One day, Tokiko had business at her daughter’s school.

“That day, I received a nasty call from Ichiro, like usual. He was saying crazy things such as ‘I can’t live anymore,’ ‘I don’t care what is going to happen to me’ and ‘I am going to die.’ Because of this call, I had the fear that he might appear in front of me on that day. [Tokiko paused.] But, despite the fact that I didn’t want to leave the house, I had to go to my daughter’s school for a meeting on that day. So, watching the people walking around me on the road, I went to the school. On my way back, too, I used the school’s back door, not the front door. It was already dark in the evening. When I came across the school’s parking lot, I noticed Ichiro’s car in the parking lot. The moment I saw it, my husband came out from of the car with a gasoline container in his hand. He poured this on to the car’s bonnet, and lit it on fire. Since everything happened so fast, I am not sure whether I actually saw him lighting the fire or not. At any event, I screamed and shouted for help. Then, other mothers from the school meeting as well as pedestrians walking around there rushed to the parking lot to see what was going on. One of the mothers, my friend, advised

me to go home, so I did. I remember my husband was shouting, ‘Ow! Ow!’ persistently. He was burned because the fire ignited the gasoline that splashed on him when he poured it on the car.”

----- [I was lost for words.]

“At that time, too, he smelled strongly of alcohol.”

-----How did you feel at that time?

“It was a combination of fear and irritation.”

Thinking back to the incident

-----Why do you think your husband burned the car?

“Probably, he was so frustrated that the only solution to his problem was to kill himself.”

----I see. But, your husband poured the gasoline onto his car and not on himself. On that day, he also purposely called you and announced that he wanted to die. If he really wanted to kill himself, he could have easily done so alone by himself. There was a possibility of secretly putting fire to your apartment and die with you, too. But that wasn’t what he did. He went through the trouble of tracking you down, waiting for you to come out from the building, and making you see him do it in public. It seems to me that he wanted to cause trouble or get a reaction from you or from the public. Forgive me for asking a rude question. Do you think he really wanted to kill himself at that time?

“As a matter of fact, although he burned many places on his body, for instance his hands and legs, his face was not burned at all.”

She continued.

“Well... [Tokiko sighed.]...I think he wanted my recognition of him, my understanding that he was suffering. I think this self-abusive action was something into which his feelings—‘why don’t you understand!’ and ‘why can’t you understand my pain!’—was poured.”

Difficulty of truly understanding each other

“My husband often complained, ‘You just don’t understand! I have to work, I have to...’ and on and on. [Tokiko paused.] So, one day, I said back to him. ‘Well, then, do you understand how I feel every day?’ He responded, ‘Your persistent noisy complaints are your feelings, of course!’ I said back to him: ‘No, Ichiro. You don’t understand my feelings. You don’t, because you make me say the same things every day. You do this since you aren’t really understanding me.

Contrary to the cuts made by a knife, injured feelings are something that you can’t see. Since we can’t see if it is there, unlike the knife’s cut, we don’t know whether it requires treatment or not. You see, I don’t know your feelings. How could I? Sometimes, I can’t even understand my child. How could I understand you, who aren’t even [biologically] related to me? We are humans and everybody thinks that they themselves are the dearest. Your request that you want me to really understand you is impossible. You shouldn’t expect such a thing in the first place.’ When I said this, he replied, ‘All right. All right. I understand. I understand.’ From my perspective, he didn’t understand, and still hasn’t understood.”

Moving secretly

One day, Tokiko secretly moved-out from the house [already separated residence]. In her mind, she was absolutely determined to divorce Ichiro.

“I couldn’t stay there any further since our lease expired. Moreover, I didn’t want him to come over and trouble us. I didn’t tell him the new address. In case of emergency, however, I informed his parents of our new address. I told him only our number. Because of this, we were quite troubled by his severe telephone attacks.”

Stalker husband

Life resumed for Tokiko at a place that Ichiro did not know. Although he persistently asked Tokiko to reveal her address, she stubbornly refused.

“But, our address was revealed to him after all. Our family had a custom of going to the neighboring town’s harvest festival every year, and my daughter said that she wanted me to drive her and her friends there. Since I felt I might encounter Ichiro at the event, I hesitated to agree. After some thought, however, I gave in. Although I didn’t want to go because of my hostile relationship with my husband, I thought this shouldn’t restrict my children’s life too much. As I expected, unfortunately, my daughter encountered Ichiro at the festival. He made her, who was at the time still going to elementary school, confess the new address. It seems like she answered vaguely, saying something like ‘we live around so and so, near so and so.’ It was he who pinpointed the place based on this information. [Tokiko paused.] One day, Ichiro knocked on our

door. I was surprised. My friend was visiting our house at that time. Ichiro said he wanted to talk to me and so wanted me to come outside. Although I denied, he pestered, ‘Please. I am asking. I really need to talk with you.’ He wanted me to come to his car since what he wants to say is very private. Since he was so persistent and my friend was there [Tokiko wanted to avoid shame], I listened to him and decided to get into his car. But the moment I got into the car, he started to turn on the engine! Since everything sounded suspicious to me from the beginning, I had kept the car door unclosed. Surprised by his action, I used all my strength to take the key away from him. When I grabbed the key, I threw it through the window as far away as I could and shouted ‘Help!’ to the pedestrians as loud as I could. There were some people on the street. But, you see, people like that really don’t want to help you in this kind of situation. [Nobody helped me.] When I fortunately escaped from the car, I ran off as fast as I could to our house.”

-----[I was lost for words, again.] So, what happened to him?

“He drove away. [Tokiko paused.] By intuition, I knew that he was going to our daughter’s school. So, I called the school, explained the situation, and told them not to hand over my daughter to Ichiro no matter what he says. As I expected, he went to the school. But, since I informed the school about our situation beforehand, they didn’t hand over my daughter.”

-----How come you knew that he was going to your daughter’s place immediately?

“Well, he has done similar things in the past, such as going to her school and causing trouble and asking her for our new address.”

-----What do you think he wanted to do with your daughter?

“I don’t know. Since he was in great agitation, I think anything could have happened.”

-----He could have kidnapped the child, or killed her and then committed suicide afterwards. [I muttered.] [Tokiko nodded.]

An all-or-nothing wager

At that time, Tokiko was asking Ichiro to sign the document required for their divorce. Although he initially stubbornly refused, the incidents he caused one after another eventually made him agree. In front of his parents, while bursting into tears, Ichiro filled out and sealed the divorce document.

“I had the divorce document sealed by him, which means that I was able to divorce him whenever I wanted. [Tokiko paused.] I didn’t divorce him, though. There were a few reasons. First, at that time, I was tired of managing our family all by myself. Around that time, I quit night work and started to work during the day. I worked at a food factory. This work demanded serious physical labor from 7 am until 4 pm. After several weeks, my hand was swollen so badly that my hands no longer looked as they used to look.”

-----Was your husband giving you living expenses at that time?

“Yes. Two-third of his salary was put into our bank account every month.”

-----Hmmm.

“Also, his company told me that if our problematic relationship doesn’t get fixed, the company will not keep him as an employee. It seems like they understood his bad performance at work was coming from his domestic life; so, if the domestic problems get solved then his work problems will also get solved. [Tokiko paused.] When I consulted my oldest son, he said, ‘It’s your life. You should decide by yourself.’”

The son’s response was not meant to detach himself from Tokiko, but to respect her free-will. The son was just over twenty years old at that time. The daughter was still going to elementary school. Tokiko continued.

“I struggled a lot asking myself what I should do. And my final reason, which is the main reason, why I decided not to divorce him is...I couldn’t burden my children physically and mentally with this problem any more. I knew: ‘He will stalk me throughout my life. Wherever I go in this small country of Japan, he will seriously track us down wherever we are and cause trouble.’ I can bear the situation if the trouble is targeted only at me. But, he was involving the children, going to their school and causing trouble. I thought these kinds of things should not happen anymore. I had to stop it. So, I decided to go for an all-or-nothing wager. I wagered my life on our problem to get solved. I said to myself: ‘Okay Tokiko, instead of trying to avoid the problem, let’s live with him again and face the problem head-on.’ Once determined, I was serious. We built a new house at the land we purchased before and started living together. [Tokiko paused.] When we made this decision, there was a request by the children. Since they were worried that there is only

me in the house, they demanded that grandmother and grandfather [Tokiko's parents] live with us, too.”

Hospitalization [second time]

One day, around this time, Tokiko came across a newspaper article written by a doctor about alcoholism and so he consulted that doctor. After the consultation, Ichiro was sent for hospitalization at the same hospital as the first time.

“During his hospitalization, I was advised to participate in the self-help group held in the hospital. My honest response to this was, ‘Why do *I* have to go to such place? It’s *not me* but *him* who is bad. Please concentrate on *his* treatment!!!’ I guess the doctor read my feelings. One day, after Ichiro’s medical examination, the doctor offered me his hand, saying that we are in the same boat, grappling with the problem together. I couldn’t reply to his handshake. I wasn’t convinced of the idea that I have to go to the self-help group, too. I just couldn’t. But, if I deny his hand, I thought nothing positive will come out of it. So, as a mere lip service, I responded to his hand, reluctantly. My shaking was far from the behavior of ‘shaking hands’; I just held out my right arm. I remember the doctor responded by grasping my reluctant hand tightly.” [Tokiko paused.]

Anyway, after this promise, although I was very reluctant, I went to the suggested self-help group only to fulfill this promise. I went there once, twice, three times.... Then one day, Ichiro told me about the unique self-help group in our neighborhood where he was actively involved. He invited me to join that group instead of the one where I was going, so I started to participate in that group.”

Husband's self-help group

Ichiro was involved with a self-group which he organized with his good friends. Although the main activity [e.g. talking about one's experience] is identical to AA and *Danshukai* [another major alcohol self-help group in Japan], there are some unique characteristics to this group: the membership consists only of good friends; the group does not belong to any nation-wide major group such as AA or *Danshukai*; a monthly fee of 800 yen [\approx US\$ 7.27] is charged to a member, which becomes the annual hot spring trip fee at the end of the year; the group is free from the problem of borrowing and lending money [Sometimes, a bankrupt alcoholic can be in a self-help group. Some self-help group suffers from one member lending money to the bankrupt alcoholic. Ichiro's group is free from that problem.]

Present days

Since this second hospitalization, Ichiro started abstaining. One day, however, Ichiro drank again. When this happened, Tokiko became mad.

“I shouted, ‘You liar! You liar! Go back to the hospital, right now!’ and so he was hospitalized again for the third time. He is currently still drinking cyanamide liquids which makes him unable to drink alcohol. I ask him to drink it every day except for the weekends when I am around in the house. I am sorry for him, but this is the rule we made for ourselves.”

The relationship between Tokiko and Ichiro has been going on since they were in junior high school. Even though Tokiko turned Ichiro down, he kept pursuing her. Although he used violence against his parents, he didn't use violence against her. Although he caused many embarrassments

because of his drinking problem, he never missed to provide the living expenses to her. Although he wanted to die, he was always seeking Tokiko, Tokiko, and Tokiko.

----Well, it sounds like your husband loves you thoroughly.

“Yeah. People around me also say that he possesses the attitude of ‘Only Tokiko’ or ‘Tokiko Forever’”

----What is it like to be a married couple who overcame such difficulties after a love marriage?

“Well, I still remember the horrible times I experienced. As long as I am alive, I don’t think I will ever forget. I say to the participants of our self-help group sarcastically: ‘you people are speaking about your experience and licking each other’s wounds, and that is okay. But, please, think also about the feelings of the family, those who were involved in your drinking problem.’ [Tokiko smiled.]”

These days, Tokiko is living a relatively stable life. However, because only one year and a half has passed since Ichiro’s last hospitalization, her feeling that he will never drink again is not certain, yet. In such an environment, they are making an effort to live their lives without alcohol, always believing that ‘the important thing is to finish each single day without alcohol.’

Additional notes: mother who died recently

Two weeks before the interview, Ichiro’s mother passed away from cancer.

“I think it’s my mother-in-law who appreciated Ichiro’s abstinence the most. Before dying, she was hospitalized. Every time when I visited her, she expressed her gratitude saying ‘Everything that happened to us recently, I owe it to you. Thank you very much.’ I think she was happy to see her son sober before she died.”

CHAPTER 4. DATA ANALYSIS

Grounded Theory Analysis

During each interview and when writing the interview report, I tried to find patterns that were characteristic of the particular interviewee. In other words, each interview was a process where I learned from the interview and found new patterns of behavior and thoughts. Sometimes I was able to verify these through a question in later interviews.

My first interviewee was Ruriko Kodama [Case 1] and my thirtieth interviewee was Tokiko Tsuda [Case 20]. Although it may appear that there is little difference between these two interviews, I am aware that I was more knowledgeable about the problems of alcoholic families during the later interview and therefore was able to ask insightful question to verify and sometimes further my understanding of certain patterns based on previous interviews. For example, when I interviewed Tokiko, I had been frequently observing *amae* [feeling of seeking care] behaviors among alcoholics which I had started to perceive as one of the behavior patterns of alcoholics. Therefore, the moment Tokiko told me that her husband declared to her that he is going to kill himself, tracked her down, appeared in front of her, and poured gasoline onto his car and not to himself [See page 453], I asked Tokiko, “Do you think your husband really wanted kill himself at that time?” This question was to verify my assumption that his behavior was based on his *amae* sentiment. If my idea was correct, there was a possibility that Tokiko understood what his behavior really meant, not the literal message of killing himself. As I speculated, Tokiko interpreted her husband’s *amae* behavior beyond the literal meaning of his words although she did not react favorably to it. Such an idea was based on my understanding from previous

interviews where wives commonly told me that the reason for their husbands' excessive drinking was because the husbands are *samishigariya* [A person who cannot stand being alone] or *amaenbo* [a person who possess strong *amae*, ≈ crying baby],” which was another way of saying that he has strong *amae*.

When looking back at my interview with Ruriko [Case 1], I do observe *amae* behavior of her husband in the text, e.g., when he said to Ruriko “I am never ever going to quit drinking”³⁸ [See page 34]. However, at that time, I was not aware of its importance and therefore did not explore this topic thoroughly. If Ruriko was my thirtieth interviewee, I may have asked her, “Why does he say such things despite the fact that such behavior will hurt him, especially in the long run?”

It is important to note that due to this ethnographical approach, there were many patterns that I became aware of during the course of the thirty interviews and therefore were not covered or properly explored in the early interviews. For example, it was in the later part of the interviews that I noticed a pattern where wives claim that their husbands are drinking in the name of *banshaku* [drinking with meal] but their *banshaku* did not mean genuine *banshaku* (e.g. they were not having meals at all, drinking on an empty stomach and eating a little bit afterwards, or drinking *sake* as a substitute of eating rice.). As it will be described later, the idea of gender roles where women have to be kind or men have to work hard, contributing to hide alcoholic's problems from the public, was developed during the interviews, too.

³⁸ A person who thinks logically may question why does he do something that will harm him ultimately? However, I became aware that this is not the way alcoholics behave. Rather, alcoholics do the opposite or cause trouble, which make sense when one understands the psychology of *amae* (Doi 1973) where alcoholics can obtain attention and care from caring people, such as their wives.

Coding Themes

During and after the interviews, I undertook processes of what grounded theory (Strauss and Corbin 1990) calls “memoing” or “coding themes.” This is an inductive coding process commonly used to analyze ethnographic interview data where the researcher searches for patterns of behavior or thoughts based on texts. Below is a sample of how I reviewed the “text.” The brackets “[]” shows some of the patterned themes I observed in this text. This is Ruriko’s [Case 1] answer to my question “Have you had any alcohol related problems that involved the police?”:

“Yes [→Police Incident]. Every time when he goes out to drink, I become nervous [→Wife’s psychological distress] because every time when he gets into trouble, I am the one who receives the phone call [→enabler, gender role where wife has to take care of her husband (There is a possibility of her behaving this way because of the gender role.)] When it comes to weekends, not only me but also my children are nervous, too. [→children’s psychological distress]. It’s very tiresome for me since I have to put myself into a half-sleep mode until he comes back home on such days... There was one time when he went into somebody else’s house when he was drunk, assuming that it was his house. We were lucky since the owner of the house was a nice person. [→permissive drinking culture for drunks (There is a possibility that the nice person was behaving this way because of the Japanese permissive drinking culture for drunks.)] Of course, for this incident, too, I took a box of cake and went there to apologize for my husband’s misconduct. [→enabler, permissive drinking culture for drunks, gender role where wife has to take care of her husband]. I occasionally receive a call from a bar’s *Mama* who asks me to pick up my husband at their bar (*Mama*’s role is to call drunk’s wife who are

responsible to take care of the drunk), too. Since I refuse these requests, they end up calling the police.”

There are a lot of patterns observable in this text. Obviously, there are many alcohol related behaviors such as co-dependence, enablement, and denial problems which alcohol treatment specialists can detect. In this sample, one can also see *Mama* whose role is to call the drunk’s wife to solve her problem. While some anthropological literature (Alison 1994) claim that the role of *Mama* or hostesses is to tame or indulge men, a service some men cannot obtain from their wives in reality [and I agree], it is also important to emphasize that *Mama* or hostesses are providing these services as part of their work. Once the drunks are behaving irresponsibly and causing trouble, such as causing problems at bars or staying at bars after closing time, the bars will call their wives or the police to solve their problem. Some bars have a space for good customers to sleep overnight, but that is mostly for the sake of the long-term financial benefit of the bars, not because they are genuinely compassionate. While there is an argument that Japanese wives do not serve the roles *Mama* provide, it is also important to credit Japanese wives who serve the indulging *Mama* role in the way the bar *Mama* does not—*Mama*-like-wives are culturally expected to do *shirinugui* for their husbands [clean up their husbands’ mess; *shirinugui* literally means wiping anus after stool, something a mother will do for her baby.]. It is fortunate for the bars’ *Mama* that they are paid for indulging men; *Mama*-like-wives are not!

Code selection and feminist anthropology

Although there are many behavior patterns observable in the interviews, many of them are not a concern of this study. As Bernard (2002) states, there is no end to the number of themes one can isolate for any text in the grounded theory approach. It was important that I select codes

based on my research question. Here, it is therefore important to return to the original research problem to understand why I selected certain codes over others.

The intention of this study was to evaluate the quiet-alcoholic hypothesis, the idea that many of Japanese heavy drinkers are harmless or that they are drinking in the acceptable realm of the Japanese drinking culture. This is important since this cultural consensus is the base of the current treatment of alcoholism and public policy surrounding alcohol related problems in Japan. In other words, this is the basis for decisions about policies of medical treatment and public services, which hold the key for improving potentially victimized people's lives. [Before the interviews, it was not clear that problems actually existed. It was possible that the current drinking culture was valid or at least not problematic.]

The method to evaluate the quiet-alcoholic hypothesis was deceptively simple: I chose wives of heavy drinkers who borderlined between non-alcoholic and alcoholic to record their stories. Feminist anthropology was useful to frame my research, and especially in the aftermath of the study if my hypothesis, rather than the quiet-alcoholic hypothesis, was correct. If the study showed that there were problems among the heavy drinkers' wives, arguments such as "The Japanese general consensus where Japanese heavy drinkers are the quiet alcoholics is ignoring the perspectives of women, who are most vulnerable to the current Japanese permissive drinking culture," became relevant. My original intention of using feminist anthropology was therefore very simple—to verify a drinking culture that may be androcentric. As the interviews proceeded, however, I became aware that not only feminist anthropology is useful for evaluating the quiet alcoholic hypothesis, but also analyzing the coded patterns I obtained from the text. As described in Chapter 2 and also later in this chapter, I used a feminist materialist approach to understand the causes of necktie-alcoholism.

Strength of ethnographical approach

Before conducting the interviews, I was mostly concerned about the Japanese androcentric permissive drinking culture, such as the *banshaku* [drinking with meal] or the *yopparai tengoku* [heaven for drunks], which men practiced or believed. At the same time, I was also concerned about gaining information on how long it took for wives to realize that their husbands were alcoholic and the time it took from then until the problem was solved, which would suggest the extent and nature of the problem in the necktie-alcoholism phenomenon. However, through the interviews, I became aware that these time periods were not sufficient to grasp the perhaps much bigger problems involved in this issue.

For example, Table 1 (p-471) shows five “periods of enduring” which are based on four events in a woman’s life: (A) the moment when she first noticed her husband’s alcohol problem, (B) the moment when she realized that her husband is definitely an alcoholic, (C) the moment when she sought help from a public institution, and (D) the moment when her problem was solved (e.g. husband abstained, she got divorced) or her current age if the problem was still unsolved. Based on these time frames, the five “periods of enduring” are:

- The period from (A) “she first noticed her husband’s alcohol-related problem” until (B) “she realized that her husband is definitely an alcoholic” (A-B)
- The period from (B) “she realized that her husband is definitely an alcoholic” until (C) “she sought help from public institution” (B-C)
- The period from (C) “she sought help from public institution”

until (D) “her problem was solved or now if the problem is still unsolved” (C-D)

- The period from (B) “she realized that her husband is definitely an alcoholic”

until (D) “her problem was solved or now if the problem is still unsolved” (B-D)

- The period from (A) “she first noticed her husband’s alcohol-related problem”

until (D) “her problem was solved or her current age if the problem is still unsolved” (A-D)

Table 1: Five Periods of Enduring for Wives

#	Wife's Age						Period of Enduring				
	First noticed drinking problem	Regarded him as alcoholic	Seek help from public	Problem under control	Divorced	Wife's age (Now)	Ambiguous period (years)	From He is alcoholic to Help from public	From Sought help to Problem solved/now	From He is alcoholic to Problem solved/now	From First drinking problem to Problem solved/now
	A	B	C	D	D	D	A-B	B-C	C-D	B-D	A-D
1	24*1	UA	57	DPNS	--	58	UA	UA	>1	UA	>34
2	36	46	50	51	--	54	10	4	1	5	15
3	31	44	44	DPNS	--	65	13	0	>21	>21	>34
4	24	25	31*4	DPNS	--	41	1	6	>10	>16	>17
5	24*1	42*2	42*X	DPNS	58	63	18	0	16	16	34
6	20	20	35	DPNS	43	47	0	15	8	23	23
7	UA	30	UA	DPNS	45	54	UA	UA	UA	15	UA
8	25*1	UA	57	DPNS	67	67	UA	UA	10	UA	42
9	26	37	38	DPNS	--	41	11	1	>3	>4	>15
10	28	49	57	DPNS	--	58	21	8	>1	>9	>30
11	24	41*1X	UA	HD	--	58	UA	UA	UA	(>)17	>34
12	--*3	--*3	--*3	DPNS	--	62	UA	--	--	--	UA
13	38	49	60	60*6	--	72	11	11	<1	11	22
14	23	48	UA	55	--	65	25	UA	UA	7	32
15	22	37	--*7	--	--	69	15	--	--	>32	>47
16	24	33	43	DPNS	--	43	9	10	<1*9	10	>19
17	53*6	65	70	DPNS	--	70	12	5	>1	>5	>17
18	--*3	--*3	--*3	DPNS	--	63	--	--	--	--	--
19	UA	--*3	--*3	DPNS	--	56	--	--	--	--	--
20	UA	38	43	43	--	54	UA	5	<1	5	UA
21	59	UA	UA	DPNS	--	69	UA	UA	UA	UA	>10
22	26*X	--*3	--*3	DPNS	--	61	--	--	--	--	--
23	UA	--*5	--*5	34	--	49	--	--	--	--	UA
24	UA	UA	UA	DPNS	--	60	UA	UA	UA	UA	UA
25	24*1	42	UA	DPNS	--	57	18	UA	UA	>15	>33
26	53	54	56	57	--	58	1	2	1	3	4
27	UA	57	UA	DPNS	--	70	UA	UA	UA	>13	UA
28	30	UA	UA	52	--	66	UA	UA	UA	UA	22
29	23	58*8	UA	DPNS	--	62	35	UA	UA	>4	>39
30	35	UA	41	DPNS	--	41	UA	UA	<1*9	UA	>6

<p><i>Italics:</i> Approximate age</p> <p>UA:The answer was unavailable. This was answerable question to the interviewee, but it was not addressed in the interview.</p> <p>-: Question was Irrelevant. This was not answerable question to the interviewee.</p> <p>DPNS: Drinking problem not solved. Husband's drinking problem has not been taken care of properly.</p> <p>HD: Husband died.</p> <p>>: More than.</p> <p><: Less than.</p> <p>*1: Based on the wife's age group's average marriage age.</p> <p>*2: Based on the first son's age (12th grade).</p>	<p>*X: Based on an assumption that the child was born 1 year after her marriage.</p> <p>*3: It is "-" since the wife does not perceive her husband has drinking problem.</p> <p>*4: Before 31.</p> <p>*5: Husband abstained before she became serious about his drinking.</p> <p>*6: Based on the usual retirement age for Japanese civil servants.</p> <p>*7: She has not sought help.</p> <p>*8: Based on the assumption that he/she retired at the age of 60.</p> <p>*9: Husband is hospitalized at the time of the interview. It is not clear if he succeeded in improving his drinking problem.</p>
---	--

The numerical results for D-B are (in years): mean 11.75, median=10.15, maximum=32, minimum=0, N=20.

This data already shows the long term of difficulty in the lives of excessive drinkers' wives, which suggests the need for early intervention programs on the public policy level. The reality, however, suggests a much worse situation than this numerical data shows. For example, consider cases such as the following:

- A wife who's (B-D) was 1 year, but (A-B), that is the period from first noticing alcohol-related problems until regarding the husband as definitely alcoholic is 10 years. Her reason for seeking help from a public institution was that her husband experienced hallucinations. [Case 26]
- A wife who did not regard her husband as a problematic drinker even though he has been diagnosed with alcoholic diabetes, high blood pressure, and hyperlipidemia. During the interview, she commented that he has no problem since she, as a "*ki-ga-yowai* (\approx unconfident and timid)" character, is good at adjusting to him. [Case 27]

- A wife who's (A-B) was 10 years and who realized that her husband is an alcoholic 25 years ago. Despite that, her problem has still not been solved. [Case 15]

The length of the individual periods was significantly affected by the wives' varied perspectives. A lower number for (B-D) did not necessarily mean "fewer problems." Checking several other factors such as (A) and (C), and investigating the wives' perception and factors influencing these perceptions was important. (A), (B), and (C) are based on the wives' personal criteria which are significantly affected by various cultural factors. Although the wives' narratives are unique and none of them are identical, some patterns of thought are repeated in their narratives which leads to the same consequence: preventing them from "recognizing their problem as a problem" or from "taking constructive action to solve the problem." It was important that I explore what factors influenced the wives' perceptions.

Strength of ethnographical approach: Kinship and Gender Related Cultural Practices

In the beginning, when I was interviewing Ruriko, I was only vaguely aware that gender roles were important factors for understanding necktie-alcoholism. It was only through the ethnographical approach where I encountered strong and tolerant wives one after another that I started to develop the idea that these wives' tolerance may be one of the causes for necktie-alcoholism not being detected on a societal level. These women's hard working, considerate, and/or patient character was remarkable. Sometimes I was surprised when these women did not perceive their husbands as problematic even though they appeared problematic to me. Why does this happen? Alcohol specialists may claim that these characters are due to the wife's behavior of co-dependence, denial, or taking the role of enabler, with which I agree. However, I started to

speculate that women's gender role in society, where they are expected/have to behave in certain ways, are also affecting these people and consequently leading them to not claim their women's rights.

The more people I interviewed, the more I also became aware that the reasons why men drink excessively are associated with men's gender roles, too. Alcohol specialists commonly claim that "alcoholics' problems are rooted in their dysfunctional family background" or "denial is one of the symptoms of alcohol dependence" which help explain the reasons why some men resort to excessive drinking or why alcoholics' problems are likely to be hidden from the public [I agree with this, too.]. However, through the wives' stories, I start speculating that the reason their husbands drink are also due to men's gender roles where they must work hard in public without complaints or are overwhelmed with responsibility as breadwinners and/or first sons who must take care of their parents.

Conceptual models through coded themes

Based on the interviews, the cultural factors that contribute to the wives' tolerant attitudes became one of the code themes in my study. Eventually, I also included men's gender roles which make them resort to drinking as code themes, too. In addition to these, there were also many behaviors characteristic of alcoholic family members such as co-dependence or denial which I observed in my data. Since I am aware that these are influential factors that worsen the situation, I marked them as part of the coded themes. I must however note that I do not have a keen sense of detecting all of these problems since I am not an alcohol treatment specialist. I coded these when the interviewee explicitly told me, when they said they are co-dependent or they were brought up in a dysfunctional family, an important attribute of co-dependant people.

All these led me to become aware that there are multiple factors contributing to Japanese necktie-alcoholism which make the problem not detectable on a societal level.

Once I realized that there were various factors affecting Japanese necktie-alcoholism, I built conceptual models by sorting the coded themes which became the “possible causes of necktie-alcoholism” [A1-F1]. In the end, as shown in Table 2 on page 478, I had four categories of causes of Japanese necktie-alcoholism: 1) Cultural elements that affect the wives’ perspectives and prevent them from recognizing their problems as problems and/or makes them tolerate their problematic situation; 2) Cultural elements that contribute to the alcoholics’ excessive drinking; 3) Factors characteristic of alcoholic families which worsen the situation; and 4) Lack of proper support by the public which worsens the situation. Categories 1) and 2) fall easily into two broad categories: a) *inshubunka* (Japanese drinking culture) related cultural practices and b) the kinship and gender related cultural practices. After these conceptual models were determined, I once again carefully went through all the data.

Causes of Necktie-Alcoholism from a Feminist Materialist Perspective

Based on my understanding that all these cultural practices can be considered socially functional in one way yet affect the interviewees in a negatively, they are “functional cultural practices that have dysfunctional side effects.” This means that each cause is “a *cultural element* that generally exists as a means to help the smooth functioning of the society; however, in an interviewee’s particular case, is working unfavorable for the individual. For example, Haruko Toda’s [Case 3] explained that one of the reasons for her husband’s excessive drinking was his predetermined destiny as the first son, who had to give up his dream for his future and carry on his father’s business as chef in a Japanese restaurant. In this case, Haruko’s husband’s problem exists because of the cultural element which expects the first son to succeed his father as head of

the family. This cultural element acts to continue the family lineage in Japan, therefore it is generally seen as functional. However, from Haruko's husband's perspective, it was unfavorable because it violated his free will, and therefore, it had "dysfunctional side effects". In the following pages [from page 489], common "cultural practices that have dysfunctional side effects" experienced by the interviewees and their husbands are enumerated with a brief explanation of both their functional purpose and problematic aspects.

The argument of this dissertation is that the enumerated "cultural practices" are the causes of the hidden alcoholism problem in Japan. As described in Chapter 2 [Theoretical Orientation], I also view all these enumerated cultural practices as products of the profit-oriented capitalist system since they are always functional when seen from the perspective of that system. This means that the whole necktie-alcoholism phenomenon is ultimately advantageous for and rooted in the Capitalist system.

The Model—Appendix 3

Appendix 3 and Table 2 show how each interviewee was affected by these cultural factors. The Table 2 also shows the type of problems (verbal abuse, physiological abuse, financial abuse, psychological abuse, cleaning up the husband's mess, child-related problems) existing in each case.

The analysis model [Appendix 3] has been created in a form future scholars can modify. Based on the premise that alcohol abuse is caused by not just a single factor but rather by various factors, it is possible to add more cultural elements based on a scholar's ideas and findings. I am aware that there are many causes which are not addressed in the table but are worth investigating, especially in the context of different societies (e.g. France, the U.S.). For example, in some societies many people believe that alcohol is a nutritionally valuable food, and this contributes to

that society's permissive drinking culture. In this case, one could add, for example, "Positive value of alcohol for nutrition" and label this as A8. In some societies, religion plays an important role in promoting certain alcohol-related behaviors (e.g., no drinking, drinking as part of rituals). In this case, one could add "Religious Factors" on the same level as "Drinking Culture" and "Kinship and "Gender Related Culture" and enumerate various sub-categories under this factor. By including more cultural factors, one may find that the argument that the profit-oriented system is the ultimate cause of necktie-alcoholism is not cross-culturally applicable. I am aware that, for example, alcoholic families tend to produce alcoholic individuals in the next generation and part of the reason for this may be better explained by human biology rather than culture.

Modified Model—Table 2

I modified the matrix [Appendix 3] to a table in order to show some observable patterns [See Table 2].

Table 2: Causes of Necktie-Alcoholism

1	KODAMA, Ruriko	Page 31-51	Drinking Culture					Kinship & Gender Related Culture						Other			
	Cultures that Contribute to Wives Tolerating		A1	A2	A3	A4	A5	A6	A7	B1	B2	B3	B4	B5	B6		G1
	Cultures that Contribute to Men's Excessive Drinking		C1	C2	C3	C4	C5	C6	C7	D1	D2	D3	D4	D5	D6	D7	D8
	Factors Characteristic to Alcoholic Families		E1	E2	E3	E4	Lack Support	F1	Type of Abuse	H1	H2	H3	H4	H5	H6		
2	SAITO, Misaki	Page 52-67	Drinking Culture					Kinship & Gender Related Culture						Other			
	Cultures that Contribute to Wives Tolerating		A1	A2	A3	A4	A5	A6	A7	B1	B2	B3	B4	B5	B6		G1
	Cultures that Contribute to Men's Excessive Drinking		C1	C2	C3	C4	C5	C6	C7	D1	D2	D3	D4	D5	D6	D7	D8
	Factors Characteristic to Alcoholic Families		E1	E2	E3	E4	Lack Support	F1	Type of Abuse	H1	H2	H3	H4	H5	H6		
3	TODA, Haruko	Page 68-88	Drinking Culture					Kinship & Gender Related Culture						Other			
	Cultures that Contribute to Wives Tolerating		A1	A2	A3	A4	A5	A6	A7	B1	B2	B3	B4	B5	B6		G1
	Cultures that Contribute to Men's Excessive Drinking		C1	C2	C3	C4	C5	C6	C7	D1	D2	D3	D4	D5	D6	D7	D8
	Factors Characteristic to Alcoholic Families		E1	E2	E3	E4	Lack Support	F1	Type of Abuse	H1	H2	H3	H4	H5	H6		
4	MEGURO, Chika	Page 89-108	Drinking Culture					Kinship & Gender Related Culture						Other			
	Cultures that Contribute to Wives Tolerating		A1	A2	A3	A4	A5	A6	A7	B1	B2	B3	B4	B5	B6		G1
	Cultures that Contribute to Men's Excessive Drinking		C1	C2	C3	C4	C5	C6	C7	D1	D2	D3	D4	D5	D6	D7	D8
	Factors Characteristic to Alcoholic Families		E1	E2	E3	E4	Lack Support	F1	Type of Abuse	H1	H2	H3	H4	H5	H6		
5	MATSUDA, Shizuyo	Page 109-128	Drinking Culture					Kinship & Gender Related Culture						Other			
	Cultures that Contribute to Wives Tolerating		A1	A2	A3	A4	A5	A6	A7	B1	B2	B3	B4	B5	B6		G1
	Cultures that Contribute to Men's Excessive Drinking		C1	C2	C3	C4	C5	C6	C7	D1	D2	D3	D4	D5	D6	D7	D8
	Factors Characteristic to Alcoholic Families		E1	E2	E3	E4	Lack Support	F1	Type of Abuse	H1	H2	H3	H4	H5	H6		
6	NITTA, Tomoko	Page 129-157	Drinking Culture					Kinship & Gender Related Culture						Other			
	Cultures that Contribute to Wives Tolerating		A1	A2	A3	A4	A5	A6	A7	B1	B2	B3	B4	B5	B6		G1
	Cultures that Contribute to Men's Excessive Drinking		C1	C2	C3	C4	C5	C6	C7	D1	D2	D3	D4	D5	D6	D7	D8
	Factors Characteristic to Alcoholic Families		E1	E2	E3	E4	Lack Support	F1	Type of Abuse	H1	H2	H3	H4	H5	H6		
7	MURAKAMI, Masako	Page 158-184	Drinking Culture					Kinship & Gender Related Culture						Other			
	Cultures that Contribute to Wives Tolerating		A1	A2	A3	A4	A5	A6	A7	B1	B2	B3	B4	B5	B6		G1
	Cultures that Contribute to Men's Excessive Drinking		C1	C2	C3	C4	C5	C6	C7	D1	D2	D3	D4	D5	D6	D7	D8
	Factors Characteristic to Alcoholic Families		E1	E2	E3	E4	Lack Support	F1	Type of Abuse	H1	H2	H3	H4	H5	H6		
8	MOMMA, Saori	Page 185-199	Drinking Culture					Kinship & Gender Related Culture						Other			
	Cultures that Contribute to Wives Tolerating		A1	A2	A3	A4	A5	A6	A7	B1	B2	B3	B4	B5	B6		G1
	Cultures that Contribute to Men's Excessive Drinking		C1	C2	C3	C4	C5	C6	C7	D1	D2	D3	D4	D5	D6	D7	D8
	Factors Characteristic to Alcoholic Families		E1	E2	E3	E4	Lack Support	F1	Type of Abuse	H1	H2	H3	H4	H5	H6		
9	SUZUKI, Noriko	Page 200-218	Drinking Culture					Kinship & Gender Related Culture						Other			
	Cultures that Contribute to Wives Tolerating		A1	A2	A3	A4	A5	A6	A7	B1	B2	B3	B4	B5	B6		G1
	Cultures that Contribute to Men's Excessive Drinking		C1	C2	C3	C4	C5	C6	C7	D1	D2	D3	D4	D5	D6	D7	D8
	Factors Characteristic to Alcoholic Families		E1	E2	E3	E4	Lack Support	F1	Type of Abuse	H1	H2	H3	H4	H5	H6		
10	TOYOTA, Kimiko	Page 219-252	Drinking Culture					Kinship & Gender Related Culture						Other			
	Cultures that Contribute to Wives Tolerating		A1	A2	A3	A4	A5	A6	A7	B1	B2	B3	B4	B5	B6		G1
	Cultures that Contribute to Men's Excessive Drinking		C1	C2	C3	C4	C5	C6	C7	D1	D2	D3	D4	D5	D6	D7	D8
	Factors Characteristic to Alcoholic Families		E1	E2	E3	E4	Lack Support	F1	Type of Abuse	H1	H2	H3	H4	H5	H6		
11	KOBAYASHI, Sakura	Page 252-272	Drinking Culture					Kinship & Gender Related Culture						Other			
	Cultures that Contribute to Wives Tolerating		A1	A2	A3	A4	A5	A6	A7	B1	B2	B3	B4	B5	B6		G1
	Cultures that Contribute to Men's Excessive Drinking		C1	C2	C3	C4	C5	C6	C7	D1	D2	D3	D4	D5	D6	D7	D8
	Factors Characteristic to Alcoholic Families		E1	E2	E3	E4	Lack Support	F1	Type of Abuse	H1	H2	H3	H4	H5	H6		
12	TAKAHASHI, Akiko	Page 272-290	Drinking Culture					Kinship & Gender Related Culture						Other			
	Cultures that Contribute to Wives Tolerating		A1	A2	A3	A4	A5	A6	A7	B1	B2	B3	B4	B5	B6		G1
	Cultures that Contribute to Men's Excessive Drinking		C1	C2	C3	C4	C5	C6	C7	D1	D2	D3	D4	D5	D6	D7	D8
	Factors Characteristic to Alcoholic Families		E1	E2	E3	E4	Lack Support	F1	Type of Abuse	H1	H2	H3	H4	H5	H6		
13	SEGAWA, Takako	Page 290-313	Drinking Culture					Kinship & Gender Related Culture						Other			
	Cultures that Contribute to Wives Tolerating		A1	A2	A3	A4	A5	A6	A7	B1	B2	B3	B4	B5	B6		G1
	Cultures that Contribute to Men's Excessive Drinking		C1	C2	C3	C4	C5	C6	C7	D1	D2	D3	D4	D5	D6	D7	D8
	Factors Characteristic to Alcoholic Families		E1	E2	E3	E4	Lack Support	F1	Type of Abuse	H1	H2	H3	H4	H5	H6		
14	KIKUCHI, Nobuko	Page 313-333	Drinking Culture					Kinship & Gender Related Culture						Other			
	Cultures that Contribute to Wives Tolerating		A1	A2	A3	A4	A5	A6	A7	B1	B2	B3	B4	B5	B6		G1
	Cultures that Contribute to Men's Excessive Drinking		C1	C2	C3	C4	C5	C6	C7	D1	D2	D3	D4	D5	D6	D7	D8
	Factors Characteristic to Alcoholic Families		E1	E2	E3	E4	Lack Support	F1	Type of Abuse	H1	H2	H3	H4	H5	H6		
15	YOSHIDA, Saki	Page 333-353	Drinking Culture					Kinship & Gender Related Culture						Other			
	Cultures that Contribute to Wives Tolerating		A1	A2	A3	A4	A5	A6	A7	B1	B2	B3	B4	B5	B6		G1
	Cultures that Contribute to Men's Excessive Drinking		C1	C2	C3	C4	C5	C6	C7	D1	D2	D3	D4	D5	D6	D7	D8
	Factors Characteristic to Alcoholic Families		E1	E2	E3	E4	Lack Support	F1	Type of Abuse	H1	H2	H3	H4	H5	H6		
16	NEMOTO, Natsuko	Page 353-385	Drinking Culture					Kinship & Gender Related Culture						Other			
	Cultures that Contribute to Wives Tolerating		A1	A2	A3	A4	A5	A6	A7	B1	B2	B3	B4	B5	B6		G1
	Cultures that Contribute to Men's Excessive Drinking		C1	C2	C3	C4	C5	C6	C7	D1	D2	D3	D4	D5	D6	D7	D8
	Factors Characteristic to Alcoholic Families		E1	E2	E3	E4	Lack Support	F1	Type of Abuse	H1	H2	H3	H4	H5	H6		
17	AIDA, Tamayo	Page 385-403	Drinking Culture					Kinship & Gender Related Culture						Other			

Cultures that Contribute to Wives Tolerating	A1	A2	A3	A4	A5	A6	A7	B1	B2	B3	B4	B5	B6		G1
Cultures that Contribute to Men's Excessive Drinking	C1	C2	C3	C4	C5	C6	C7	D1	D2	D3	D4	D5	D6	D7	D8
Factors Characteristic to Alcoholic Families	E1	E2	E3	E4	Lack Support	F1	Type of Abuse	H1	H2	H3	H4	H5	H6		
18	HANADA, Fumiko	Page 403-418	Drinking Culture					Kinship & Gender Related Culture					Other		
Cultures that Contribute to Wives Tolerating	A1	A2	A3	A4	A5	A6	A7	B1	B2	B3	B4	B5	B6		G1
Cultures that Contribute to Men's Excessive Drinking	C1	C2	C3	C4	C5	C6	C7	D1	D2	D3	D4	D5	D6	D7	D8
Factors Characteristic to Alcoholic Families	E1	E2	E3	E4	Lack Support	F1	Type of Abuse	H1	H2	H3	H4	H5	H6		
19	MIURA, Yumiko	Page 418-433	Drinking Culture					Kinship & Gender Related Culture					Other		
Cultures that Contribute to Wives Tolerating	A1	A2	A3	A4	A5	A6	A7	B1	B2	B3	B4	B5	B6		G1
Cultures that Contribute to Men's Excessive Drinking	C1	C2	C3	C4	C5	C6	C7	D1	D2	D3	D4	D5	D6	D7	D8
Factors Characteristic to Alcoholic Families	E1	E2	E3	E4	Lack Support	F1	Type of Abuse	H1	H2	H3	H4	H5	H6		
20	TSUDA, Tokiko	Page 433-	Drinking Culture					Kinship & Gender Related Culture					Other		
Cultures that Contribute to Wives Tolerating	A1	A2	A3	A4	A5	A6	A7	B1	B2	B3	B4	B5	B6		G1
Cultures that Contribute to Men's Excessive Drinking	C1	C2	C3	C4	C5	C6	C7	D1	D2	D3	D4	D5	D6	D7	D8
Factors Characteristic to Alcoholic Families	E1	E2	E3	E4	Lack Support	F1	Type of Abuse	H1	H2	H3	H4	H5	H6		
21	UEDA, Mitsuko	Not listed	Drinking Culture					Kinship & Gender Related Culture					Other		
Cultures that Contribute to Wives Tolerating	A1	A2	A3	A4	A5	A6	A7	B1	B2	B3	B4	B5	B6		G1
Cultures that Contribute to Men's Excessive Drinking	C1	C2	C3	C4	C5	C6	C7	D1	D2	D3	D4	D5	D6	D7	D8
Factors Characteristic to Alcoholic Families	E1	E2	E3	E4	Lack Support	F1	Type of Abuse	H1	H2	H3	H4	H5	H6		
22	YABE, Kanae	Not listed	Drinking Culture					Kinship & Gender Related Culture					Other		
Cultures that Contribute to Wives Tolerating	A1	A2	A3	A4	A5	A6	A7	B1	B2	B3	B4	B5	B6		G1
Cultures that Contribute to Men's Excessive Drinking	C1	C2	C3	C4	C5	C6	C7	D1	D2	D3	D4	D5	D6	D7	D8
Factors Characteristic to Alcoholic Families	E1	E2	E3	E4	Lack Support	F1	Type of Abuse	H1	H2	H3	H4	H5	H6		
23	FUSHIMI, Nobuyo	Not listed	Drinking Culture					Kinship & Gender Related Culture					Other		
Cultures that Contribute to Wives Tolerating	A1	A2	A3	A4	A5	A6	A7	B1	B2	B3	B4	B5	B6		G1
Cultures that Contribute to Men's Excessive Drinking	C1	C2	C3	C4	C5	C6	C7	D1	D2	D3	D4	D5	D6	D7	D8
Factors Characteristic to Alcoholic Families	E1	E2	E3	E4	Lack Support	F1	Type of Abuse	H1	H2	H3	H4	H5	H6		
24	MIZUNO, Kanako	Not listed	Drinking Culture					Kinship & Gender Related Culture					Other		
Cultures that Contribute to Wives Tolerating	A1	A2	A3	A4	A5	A6	A7	B1	B2	B3	B4	B5	B6		G1
Cultures that Contribute to Men's Excessive Drinking	C1	C2	C3	C4	C5	C6	C7	D1	D2	D3	D4	D5	D6	D7	D8
Factors Characteristic to Alcoholic Families	E1	E2	E3	E4	Lack Support	F1	Type of Abuse	H1	H2	H3	H4	H5	H6		
25	HATANAKA, Kyoko	Not listed	Drinking Culture					Kinship & Gender Related Culture					Other		
Cultures that Contribute to Wives Tolerating	A1	A2	A3	A4	A5	A6	A7	B1	B2	B3	B4	B5	B6		G1
Cultures that Contribute to Men's Excessive Drinking	C1	C2	C3	C4	C5	C6	C7	D1	D2	D3	D4	D5	D6	D7	D8
Factors Characteristic to Alcoholic Families	E1	E2	E3	E4	Lack Support	F1	Type of Abuse	H1	H2	H3	H4	H5	H6		
26	KAMATA, Ryoko	Not listed	Drinking Culture					Kinship & Gender Related Culture					Other		
Cultures that Contribute to Wives Tolerating	A1	A2	A3	A4	A5	A6	A7	B1	B2	B3	B4	B5	B6		G1
Cultures that Contribute to Men's Excessive Drinking	C1	C2	C3	C4	C5	C6	C7	D1	D2	D3	D4	D5	D6	D7	D8
Factors Characteristic to Alcoholic Families	E1	E2	E3	E4	Lack Support	F1	Type of Abuse	H1	H2	H3	H4	H5	H6		
27	DOI, Makiko	Not listed	Drinking Culture					Kinship & Gender Related Culture					Other		
Cultures that Contribute to Wives Tolerating	A1	A2	A3	A4	A5	A6	A7	B1	B2	B3	B4	B5	B6		G1
Cultures that Contribute to Men's Excessive Drinking	C1	C2	C3	C4	C5	C6	C7	D1	D2	D3	D4	D5	D6	D7	D8
Factors Characteristic to Alcoholic Families	E1	E2	E3	E4	Lack Support	F1	Type of Abuse	H1	H2	H3	H4	H5	H6		
28	SONODA, Yukari	Not listed	Drinking Culture					Kinship & Gender Related Culture					Other		
Cultures that Contribute to Wives Tolerating	A1	A2	A3	A4	A5	A6	A7	B1	B2	B3	B4	B5	B6		G1
Cultures that Contribute to Men's Excessive Drinking	C1	C2	C3	C4	C5	C6	C7	D1	D2	D3	D4	D5	D6	D7	D8
Factors Characteristic to Alcoholic Families	E1	E2	E3	E4	Lack Support	F1	Type of Abuse	H1	H2	H3	H4	H5	H6		
29	NODA, Yuko	Not listed	Drinking Culture					Kinship & Gender Related Culture					Other		
Cultures that Contribute to Wives Tolerating	A1	A2	A3	A4	A5	A6	A7	B1	B2	B3	B4	B5	B6		G1
Cultures that Contribute to Men's Excessive Drinking	C1	C2	C3	C4	C5	C6	C7	D1	D2	D3	D4	D5	D6	D7	D8
Factors Characteristic to Alcoholic Families	E1	E2	E3	E4	Lack Support	F1	Type of Abuse	H1	H2	H3	H4	H5	H6		
30	SAKAMOTO, Nami	Not listed	Drinking Culture					Kinship & Gender Related Culture					Other		
Cultures that Contribute to Wives Tolerating	A1	A2	A3	A4	A5	A6	A7	B1	B2	B3	B4	B5	B6		G1
Cultures that Contribute to Men's Excessive Drinking	C1	C2	C3	C4	C5	C6	C7	D1	D2	D3	D4	D5	D6	D7	D8
Factors Characteristic to Alcoholic Families	E1	E2	E3	E4	Lack Support	F1	Type of Abuse	H1	H2	H3	H4	H5	H6		

Table 2: Summary of the dysfunctions of functional cultures present in the individual cases.

Firstly, as also shown in Appendix 3, I tried to show that the cause of alcoholics' "excessive" drinking is usually not a single factor, but rather a multitude of factors.

Secondly, the arrangement of the cultural factors is organized such that the same or related cultural factors are often lined up vertically or horizontally, or are near to each other. This is important to make the point that certain cultural factors affect both husbands and wives. They encourage the husbands to resort to excessive drinking and the wives to tolerate such husbands. For example, *banshaku* [drinking with a meal] is a cultural practice that affects both husbands and wives. It encourages the husband to drink [=C1] and the wife to permit her husband to drink [A1]. [See Figure 1 Alignment of cultural elements]

Figure 1. Alignment of cultural elements

1	KODAMA, Ruriko	Page 31-	Drinking Culture							Kinship & Gender Related Culture							Other
	Cultures that Contribute to Wives Tolerating		A1	A2	A3	A4	A5	A6	A7	B1	B2	B3	B4	B5	B6		G1
	Cultures that Contribute to Men's Excessive Drinking		C1	C2	C3	C4	C5	C6	C7	D1	D2	D3	D4	D5	D6	D7	D8

A1	<i>Banshaku</i> [Drink with meal] Culture	C1	<i>Banshaku</i> Culture
A2	<i>Yopparai Tengoku</i> [Heaven for Drunk] culture	C2	<i>Yopparai Tengoku</i> culture
A3	Culture that associate “alcohol/capable drinker” with “men/masculinity”	C3	Culture that associate “alcohol/capable drinker” with “men/masculinity”
A4	Culture of “Drinking as an Extension of Work”	C4	Culture of “Drinking as an Extension of Work”
A5	Culture of “Drinking is the Means of Releasing Stress”	C5	Culture of “Drinking is the Means of Releasing Stress”
A6	Japanese Criteria of Alcoholism	C6	Japanese Criteria of Alcoholism
A7	Wives’ Ignorance of Alcohol Problems	C7	Husbands’ Ignorance of Alcohol Problems
B1	The Cultural Understanding of Marriage	D1	Responsibilities of the First Son as the Successor of the Household
B2	The Culture that Expects Wife to live with and Take Care of Her Parents-in-Law	D2	The Culture that Expects Wife to live with and Take Care of Her Parents-in-Law
B3	Expectation towards Women	D3	Expectation towards Men (Stress from Work, Stress from the Responsibilities to Provide for the family)
B4	Cultural Norms that Prevent Women from Becoming Financially Independent	D4	Masculinity (Men’s Level of Education)
B5	The Culture of <i>Uchi</i> (inner) and <i>Soto</i> (Outer) (Culture of Avoiding Shame)	D5	Masculinity (Culture of Men with Few Words)
B6	Lack of Communication between Husband and Wife	D6	Masculinity (Cultural Expectation of Men Repressing Their <i>Amae</i>)
		D7	Removal of Tension Due to the Accomplishment of Tasks as a Father
		D8	Problems in the Husband’s Childhood Environment and/or in his “blood”

I also located E1 Wife’s Dysfunctional Family Background and/or Existence of Alcoholics within her Family Line and E2 Husband’s Dysfunctional Family Background and/or Existence of Alcoholics within his Family Line next to each other, to see if the idea “person with co-dependence marries with a person with co-dependence” holds true. Since I did not ask every interviewee about her and her husband’s childhood in detail, it is possible that had I done so, more boxes would be filled with black than shown in the table. [See Figure 2 Alignment of cultural elements]

Figure 2. Alignment of cultural elements

1	KODAMA, Ruriko	Page 31-	Drinking Culture							Kinship & Gender Related Culture						Other	
	Cultures that Contribute to Wives Tolerating		A1	A2	A3	A4	A5	A6	A7	B1	B2	B3	B4	B5	B6	G1	
	Cultures that Contribute to Men's Excessive Drinking		C1	C2	C3	C4	C5	C6	C7	D1	D2	D3	D4	D5	D6	D7	D8
	Factors Characteristic to Alcoholic Families		E1	E2	E3	E4	Lack Support	F1	Type of Abuse	H1	H2	H3	H4	H5	H6		



Thirdly, based on the fact that all women had problems which were not solved, all boxes for F1 are colored in black.

Fourthly, I included various types of abuse/problem: H1-H6. Obviously these are not the causes but rather outcomes of necktie-alcoholism. Here, my intention was to show what types of problems exist in each case. One can see that these types of problems are disguised by other factors such as cultural practice of A1-G1. Since physical abuse [H2] is associated with “shame” in Japan, there is a possibility that some interviewees disguised this problem [see H 2 Physical Abuse].

Data and the Possibility for Future Statistical Analysis

This research cannot give much of a statistically significant indication of how common the described problems actually are because of the inductive ethnographical method and the study's small sample. A deductive approach or investigating of how common this kind of problem actually is in the population at large, is a problem for further study. By using the current data and my understandings, this section suggests some of the possible directions for future deductive research.

One question we may want to explore is: How widespread these problems actually are in Japan? In this study, all cases [30 out of 30!] had problems that need to be addressed, which suggests that many Japanese heavy drinkers are not problem-free. However, it is improper to conclude from this study that all Japanese alcoholic families are suffering from such problems since the sample is too small. Conducting a study with a larger sample is necessary. The qualitative research method with big samples is, however, too costly, time consuming, difficult, and therefore unrealistic. One way of approaching this problem may therefore be to look at the population of problem-free alcoholic (excessive drinkers) families in Japan. Although I hypothesize that such problem-free alcoholics do not exist, they may. Estimating the number of problem-free alcoholics within a large population of heavy drinkers will shed light on how prevalent the problems this study showed are in Japan.

Another direction for further study is to explore where we need to change the most in order to efficiently improve the necktie-alcoholism phenomenon. All cultural practices are worth considering for change, but some may be more urgent or important than others. This study cannot provide a precise answer to this question mostly due to the inductive method used here [See Figure 3].

Figure 3. Causes of Necktie-Alcoholism

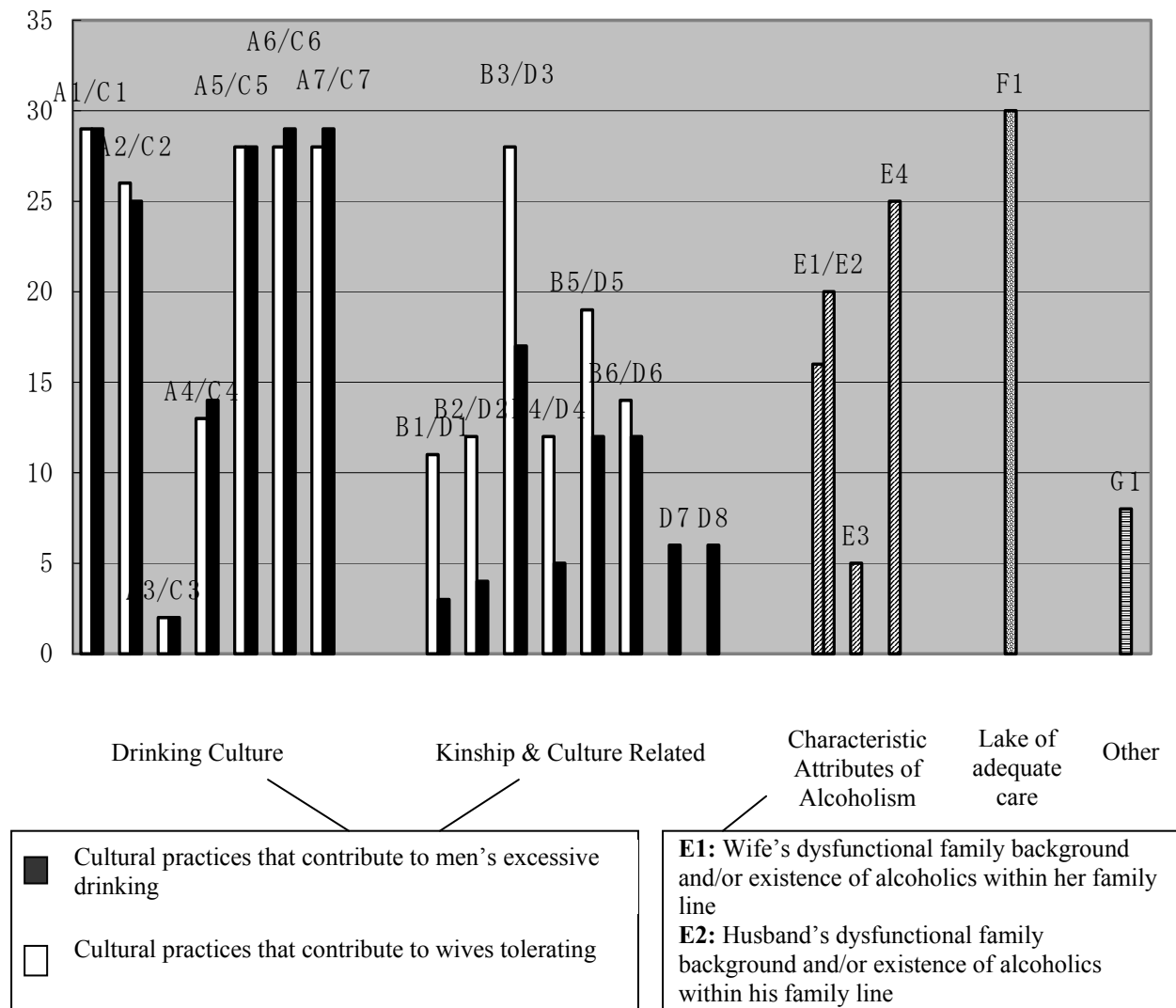

According to the data, the following causes show up more often than others:

F1 Inadequate Public Support (→applied to all 30 cases)

A1/C1 *Banshaku* [drinking with meal] cultural practice, (→applied to 29 cases for A1 and 29 cases for C1)

A6/C6 Japanese criteria of alcoholism (→applied to 29 cases for A6 and 28 cases for C6)

A7/C7 Wives/husbands' lack of knowledge about alcohol problems (→applied to 29 cases for A7 and 28 cases for C7)

A5/C5 Cultural idea of “drinking is the means of releasing stress,” (→applied to 29 cases for A5 and 28 cases for C5)

B3 Cultural Expectations towards Women (→applied to 28 cases)

A2/C2 *Yopparai tengoku* [heaven for drunkenness] (→applied to 26 cases for A2 and 26 cases for C2)

E4 Strong Denial (→applied to 25 cases)

This does not, however, mean that the causes that appear less frequently in this data are insignificant or not influential compared to the ones that appeared more often. For example, drinking culture related cultural practices (352 times) show a higher frequency than kinship and gender related cultural practices (161 times). This was not because kinship and gender related cultural practices are insignificant, but mostly due to two reasons related to the inductive research method: 1) in the beginning I was not aware that kinship and gender related factors were significant and therefore did not explore them in all interviews, and 2) the criteria of some cultural factors, especially the kinship and gender related cultural practices, are at this stage strictly defined in order to show only clear cases where a certain cultural practice is affecting the interviewee.

For example, at the beginning, I could not see the relationship between the first-son's role in Japanese society and Japanese necktie-alcoholism even though cues of such connection were apparent in the texts. Although many people, such as Ruriko [Case 1] or Haruko [Case 3], were telling me about mother-in-law problems or stories of a husband's constrained life as a first

son, I only later started to perceive these issues as among the influential causes and therefore did not explore the problem properly. I saw the connection only after a casual conversation with a knowledgeable member of a self help group who told me, “Did you know that alcoholism is a disease for a *first son* and a last child, Keiko-san?” For me, this comment was very insightful. Although I did not intentionally try to interview first-son’s wives, 26 cases out of the 30 were wives of the heir or first son! Knowing the general constraints placed on first sons in Japan, the coded patterns such as “agony from mother-in-law problem,” “work related stress,” “wife’s tolerant behavior,” started to connect with one another which made me see this problem from a kinship and gender related perspective. Unfortunately, this happened during the late stage of my fieldwork. I regret not asking wives how they view their husband’s role as first son or heir and how this role shaped their behavior. If I had had this view at the beginning, I may have asked different questions which in turn may have shown more frequency in the category of the kinship and gender related cultural practices. In Figure 3, only 3 cases apply to the D1 Responsibility of the first son as the successor of the household. These cases show a strong relationship between this cultural practice and the husband’s behavior where he resorted to excessive drinking. It is important to note that there are, however, 26 first sons and/or heirs in this study. Although the wives did not explicitly state that their husband’s role as heir/first son is the cause of his drinking, it is possible that this cultural practice is one of the causes for delaying intervention from public services. There is also a possibility that my sample, where twenty six of the husbands were heirs/first sons, can be a demographical coincidence. Investigating the birth order and the occurrence of alcoholism in Japan is a possibility for future study. In this case, it is important to investigate the co-relationship with other kinship and gender related cultural practices [i.e. the heir’s wife may be affected by the enumerated causes which shapes her character to become more tolerant than non-heir/non-first sons who is alcoholic.]

In Table 2, each category [Japanese drinking culture, kinship and gender related cultural practices] of cultural practices lined up vertically or diagonally are often concerned with the same cultural practice or closely related to one another in some way. For example, C2 Yopparai tengoku [heaven for drunks] cultural practice and A2 Yopparai tengoku cultural practice concerns the same cultural factor but are different since one contributes to making men resort to drinking and the other contributes to making their wives to tolerate such husbands.

In this study, drinking cultural elements lined up vertically showed strong correlations. However, kinship and gender related cultural elements located close together did not show strong correlations as I had expected. This was mostly due to the inductive research method where I did not explore the kinship and gender related problems consistently and systematically. Another reason is that gender roles affect men and women in different ways and problems due to a gender role do not necessarily affect both genders. For example, one can assume a correlation between D1 Responsibilities of the First Son as the Successor of the Household (Contributes to men's excessive drinking) and B2 The Culture that Expects Wife to live with and Take Care of Her Parents-in-Law (Contributes to wives tolerating) and D2 The Culture that Expects Wife to live with and Take Care of Her Parents-in-Law (Contributes to men's excessive drinking) because, in Japan, the first son or successor's wife is expected to take care of her parents-in-law. When one of these factors applies, it indicates that the husband is the first son or the successor which suggests a likelihood of having problems related to this issue. However, B3 Expectation towards Women does not necessarily affect D3 Expectation towards Men (Stress from Work, Stress from the Responsibilities to Provide for the family) in the way D1, B2 and D2 affect each other. One may assume that masculine men (e.g. highly educated, hardworking, independent) expect women to be feminine (e.g. kind, understanding, financially insecure) and vice versa, but the association between the two seems less significant compared to the association between D1, B2, and D2. In

Figure 4, some of the cultural elements that one may expect to show significant correlation due to the conceptual cultural association are listed with their correlations in this study. In appendix 4, all the correlations between the causes are listed.

Figure 4. Correlation of cultural elements

1	KODAMA, Ruriko	Page 31-	Drinking Culture							Kinship & Gender Related Culture							Other
Cultures that Contribute to Wives Tolerating			A1	A2	A3	A4	A5	A6	A7	B1	B2	B3	B4	B5	B6		G1
Cultures that Contribute to Men's Excessive Drinking			C1	C2	C3	C4	C5	C6	C7	D1	D2	D3	D4	D5	D6	D7	D8

Cultures that Contribute to Wives Tolerating		Cultures that Contribute to Men's Excessive Drinking		correlation
A1	<i>Banshaku</i> [Drink with meal] Culture	C1	<i>Banshaku</i> Culture	1
A2	<i>Yopparai Tengoku</i> [Heaven for Drunk] culture	C2	<i>Yopparai Tengoku</i> culture	0.88
A3	Culture that associate "alcohol/capable drinker" with "men/masculinity"	C3	Culture that associate "alcohol/capable drinker" with "men/masculinity"	0.48
A4	Culture of "Drinking as an Extension of Work"	C4	Culture of "Drinking as an Extension of Work"	0.93
A5	Culture of "Drinking is the Means of Releasing Stress"	C5	Culture of "Drinking is the Means of Releasing Stress"	1
A6	Japanese Criteria of Alcoholism	C6	Japanese Criteria of Alcoholism	0.69
A7	Wives' Ignorance of Alcohol Problems	C7	Husbands' Ignorance of Alcohol Problems	0.69
B2	The Culture that Expects Wife to live with and Take Care of Her Parents-in-Law	D1	Responsibilities of the First Son as the Successor of the Household	0.05
B2	The Culture that Expects Wife to live with and Take Care of Her Parents-in-Law	D2	The Culture that Expects Wife to live with and Take Care of Her Parents-in-Law	0.10
B3	Expectation towards Women	D3	Expectation towards Men (Stress from Work, Stress from the Responsibilities to Provide for the family)	0.04
B3	Expectation towards Women	D4	Masculinity (Men's Level of Education)	0.12
B3	Expectation towards Women	D5	Masculinity (Culture of Men with Few Words)	0.13
B3	Expectation towards Women	D6	Masculinity (Cultural Expectation of Men Repressing Their <i>Amae</i>)	0.22
B4	Cultural Norms that Prevent Women from Becoming Financially Independent	D4	Masculinity (Men's Level of Education)	0

Some cultural practices may show a correlation within a category. For example, studies of alcohol and alcohol abuse claim that a child raised in an alcoholic family or dysfunctional family is likely to marry a person with a similar background. As noted, since my study did not explore the family background of both husband and wife in detail, there is a possibility that correlations exist although my study does not show them. Also, in the interview data, many men drank in the context of *banshaku* and became drunk. There is, thus, a likeliness that C1 *Banshaku* [Drink with meal] Culture may occur together with C2 *Yopparai Tengoku* [Heaven for Drunk] culture. In Figure 5, some of the cultural elements within a category, which may show correlations when deductive research are conducted, are listed with correlations.

Figure 5. Correlation of cultural elements

			correlation	
A1	<i>Banshaku</i> [Drink with meal] Culture	A2	<i>Yopparai Tengoku</i> [Heaven for Drunk] culture	0.47
C1	<i>Banshaku</i> Culture	C2	<i>Yopparai Tengoku</i> culture	0.42
A6	Japanese Criteria of Alcoholism	A7	Wives' Ignorance of Alcohol Problems	1
C6	Japanese Criteria of Alcoholism	C7	Husbands' Ignorance of Alcohol Problems	1
D1	Responsibilities of the First Son as the Successor of the Household	D2	The Culture that Expects Wife to live with and Take Care of Her Parents-in-Law	-0.13
D3	Expectation towards Men (Stress from Work, Stress from the Responsibilities to Provide for the family)	D4	Masculinity (Men's Level of Education)	0.21
D3	Expectation towards Men (Stress from Work, Stress from the Responsibilities to Provide for the family)	D5	Masculinity (Culture of Men with Few Words)	-0.11
D3	Expectation towards Men (Stress from Work, Stress from the Responsibilities to Provide for the family)	D7	Removal of Tension Due to the Accomplishment of Tasks as a Father	-0.40
E1	Wife's Dysfunctional Family Background and/or Existence of Alcoholics within Her Family Line	E2	Husband's Dysfunctional Family Background and/or Existence of Alcoholics within his Family Line	-0.09

Collecting more data through a deductive method and analyzing the data statistically will provide a better numerical understanding of this issue. It will shed light on which causes are more significant; how “problems” relate to each other; or what additional variables help to predict the observed distributions and connections. Through this process one may discover a genuine way to eliminate or reduce alcohol related problems in Japan.

Dysfunction of Functional Cultures: Cultural Factors that Contribute to the Phenomenon of Wives Tolerating Husband’s Excessive Drinking

This section enumerates and briefly helps explain the dysfunction of functional cultures that affect the wives’ perspectives and prevent them from recognizing their problems as problems and/or makes them tolerate their problematic situation.

1) *Inshubunka* [Japanese Drinking Culture]

A1 *Banshaku* cultural practice

Banshaku means “drinking during the evening meal time,” and is the most common drinking pattern in Japan. According to the Prime Minister’s Public Relations Office (1995), 70.3% of drinkers answered “he/she drinks mostly at home rather than outside” which indicates the widespread *banshaku* culture in Japan. Takeshi Sasaki, in a chapter entitled *Banshaku to Bunka (Banshaku and Culture)*, describes the function of the *banshaku* culture as follows:

Banshaku is a custom whose purpose is to cure one from tiredness by dispensing with formality and releasing one’s tension physically and psychologically after work. While

drinking with a meal in the at-home atmosphere, there is no special reason to drink, no communication to worry about, nor any strain. It is the moment one returns to one's natural self. The real pleasure of *banshaku* is in the joy of ending the day for the coming tomorrow, at home, with a home-made dish, and without seeking a too large amount (Sasaki 1975: 40, my translation)

The *Banshaku* culture contributes to the wives perceiving the following behaviors of their husbands as positive or not problematic, which contributes to the phenomenon of necktie-alcoholics being left behind without proper treatments.

- Husband drinks after work in the evening.
- Husband drinks with evening meal.
- Husband drinks to remove tiredness and/or release stress.
- Husband drinks to sleep well afterwards.
- Husband drinks to transfer himself from working-mode to relaxed-mode.

These behaviors, or the wives' impressions their of husband's behaviors, are cues for detecting the presence of *banshaku* practices in the interviewees' households. At least one of these cues applies to each interviewee's husband, which indicates the frequency of *banshaku* among alcoholics. While Sasaki's (1975) description of *banshaku* sheds light on the functional aspect of *banshaku* for male drinkers, this dissertation focuses on the flip side of this cultural practice where many drunks actually hurt other family members but, in the name of *banshaku*, their behavior is excused or tolerated. For example, Noriko's husband [Case 9] did *banshaku*

every night and he degraded Noriko by saying things such as “You are dull-witted and slow. That is the reason why I call you dumb all the time.” There was an occasion where he drank and came to Noriko’s bedroom while she was sleeping. In the bedroom, he criticized Noriko’s faults endlessly. Her daughter is frightened of this father and asks Noriko to accompany her during the night when she needs to go near her drunken father in order to go to the kitchen. This kind of situation, which was reported throughout the thirty interviews, illustrates the problems (often not seen as major problems by wives) associated with *banshaku* cultural practices.

It is also important to note that *banshaku* is a culturally accepted drinking pattern that implies safety from alcohol dependence syndrome (e.g. drink with meal, do not drink too much). However, there are people whose drinking pattern does not follow these restrictions, but they nevertheless call it “*banshaku*.” In the interviews, there were men whose drinking patterns were called *banshaku* but in fact, although they were drinking during the evening meal time, they were doing so without much food [Case 18]. There were also men who were drinking *sake* as a substitute for eating rice. In case of Yuko’s husband [case 29], drinking and eating happens at different times. Every evening, he does *karanomi* [drinks with empty stomach] first and then eats. What he means by having dinner is having some relishes. He does not have any staples. According to Yuko, he has been practicing this eating habit since they got married forty years ago.³⁹

Also note that some alcoholics stated that a *tanshinfunin* (business bachelor) period was the time when they significantly increased their alcohol consumption [Case 17 & 28]. A business bachelor’s evening meal habit (drinking without a substantial meal) and his life without family

³⁹ “Whether *banshaku* has to take place during *ban* (the evening) time,” and “at home” and “whether *banshaku* has to accompany a meal” are unclear, which is reflected in the inconsistent meanings of *banshaku* in Japanese dictionaries.

(empty time) are the background of this tendency. This is another example of how the profit-oriented system contributes to men's excessive drinking in Japan.

A2 *Yopparai Tengoku* [Heaven for Drunks]

Yopparai tengoku means "heaven for drunks/drunkenness," and people use this term to mean "Japan." *Yopparai tengoku* encourages people (specifically men) to drink and get drunk. It also guarantees that drunken people will not be stigmatized as shameful for anything they do when they are drunk. In Haruko's story [Case 3], she describes a drunken stranger knocking on her house's door believing it to be his home. The fact that such behaviors were often treated with compassion illustrates the tolerant attitude of Japanese people towards drunken people in general.

Behind this cultural idea lies people's belief in the function of drinking: the drug alcohol is used to transfer people from *tatema* [restrained] mode to *honne* [unrestrained] mode, which makes effective communication possible. There are many Japanese proverbs which emphasize the function of drinking to understand people on a deeper level: "*Kagami wa youbou o mise, sake wa kokoro o arawasu*. [A mirror reflects features, while alcohol reflects the mind.]; "*Kin wa hi de kokoromi, hito wa sake de kokoromiru*. [Test gold with fire, test people with alcohol.]; "*Sake wa honshin o arawasu* [Alcohol reveals one's real intention]; "*Hito o shiru wa sake ga chikamichi*. [The shortcut to understand a person is to drink together.]; "*Hito yoite honshin o arawasu*. [Drunkenness reveals one's real intension.]" (Nagayama and Kawashima 1988). According to the Prime Minister's Public Relations Office (1989), 73.2% of Japanese people (80.9% of men) believe that alcohol facilitates human relationships, which suggests the prevalence of this cultural idea in Japanese society.

Yopparai tengoku exists based on the cultural practice where the frustration, anger and anxiety of the victims caused by the drunks are easily forgiven or considered insignificant. In this

context, such emotions are mostly experienced by people who are responsible for taking care of the drunks, namely the alcoholics' wives. Like Noriko [Case 9] described earlier, many husbands behaved badly (e.g. grumpy, loud, annoying, quarrelsome) while drunk and annoyed their wives. Yuko [Case 29], whose husband grumbles and becomes tedious when drunk, even perceived this behavior as "*sake o nomu hito no tokken* [drunken people's special right]" instead of as annoyance or something that reduces her freedom [!]. Some worried wives, such as Takako [Case 13], checked the bars where their husbands may be drinking. She, whose husband once had a traffic accident while drunk, waited anxiously everyday for his safe return, without being able to sleep. Her statement, describing her feeling when she was concerned about her husband coming back safely in the evening, illustrates the common feeling experienced by wives of alcoholics who frequently drink outside: "I anxiously waited for his return without sleeping everyday. While waiting, only negative things came to my mind: 'What if he has caused a traffic accident again?'; 'What if he became involved in some kind of trouble?'; 'What if his disease becomes worse?' Thinking about those days now, I think I was very exhausted, perhaps more than the alcoholic Ichiro himself." Note that these feelings are wives' everyday emotions, the problems which they cannot overcome, in part, due to the influence of *yopparai tengoku* cultural practices. *Yopparai tengoku* is too forgiving for many negative consequences of drunk people's behavior, which significantly contributes to the phenomenon of necktie-alcoholics being left behind without proper medical treatment.

A3 Cultural association between "alcohol/capable drinker" and "men/masculinity"

One of the indices for measuring Japanese masculinity is how much alcohol the man can tolerate. In Japan, there is the structural equation "men = drinking gender; women = non drinking gender." There is also a chain of association— "capable drinker (does not become drunk) →

jougo (capable drinker with positive connotation) → capable → successful (winner) → strong → masculine”—as opposed to the other association—“incapable drinker → *geko* (incapable drinker with negative connotation) → incapable → unsuccessful (loser) → weak → not masculine.” The designation of men as the drinking gender may exist because alcohol disinhibits people, and, for men, induces masculine behavior (e.g. combative, aggressive, dominant behavior). Another association can be drawn from the cultural expectation that it is men, not women, who will have careers. Since men are expected to “not pursue their *amae*” (\approx expected “not to depend” but rather “be dependable”), the flip side of this cultural expectation is the situation where they release their stress through drinking; and therefore “men = drinking gender.” The association of capable drinker/ winner and drinking may be related to the function of drinking in effect in the work sphere where being able to control oneself under the influence of alcohol holds the key to success in Japanese society.

In this study, many men conformed to the cultural association between “alcohol/capable drinker” and “men/masculinity.” Some showed their aggressive masculine behavior while drunk and others showed the emotional inhibition of men who resort to excessive drinking. For example, Ruriko’s husband [Case 1] changed his behavior dramatically when he started drinking. Other men such as Nami’s husband [Case 29] drank because his boss gave him a hard time by intentionally allotting him a tedious task. He wanted to complain against his boss’ unfairness, but couldn’t since he was an unskilled man who was afraid of being fired if he complained. Tokiko’s husband [Case 20] was a man who worked for a prestigious company’s sales division. He drank frequently in the context of *settai* [business related reception] where he had to control his emotions while drinking, which was the key to his success at work. This cultural association between “alcohol/capable drinker” and “men/masculinity” contributes to the enabler role of

Japanese women who accept men's drinking and support their drinking behavior with feminine gender roles (e.g. caring and understanding).

A4 Cultural Idea of “Drinking as an Extension of Work”

The function of drinking is especially prominent in the work environment, where people intentionally drink to establish strong human relationships with customers and coworkers. Because of this, there is a cultural idea in Japan that “drinking is an extension of work”. The reason why this works— i.e. why Japanese put so much importance on going to bars with work related people (e.g. bosses, colleagues, subordinates) after work, or organizing work related parties throughout the year, such as *hanami* (cherry blossom viewing party), *bonenkai* (Year end party), *shinnenkai* (beginning of the year party), *kangeikai* (welcoming party), *sogeikai* (farewell party)— is that Japanese seek “emotional unity” at work, probably more so than Euro-Americans (Nakane 1970). Why they seek emotional unity at work is rooted in the Japanese people's criteria of friendship, which must be a strong *amae* relationship, using Doi's term (1973). An *amae* relationship is a relationship in which people communicate by one person accurately guessing and satisfying the other person's unarticulated needs (*amae*). (For more information on Japanese workers drinking with colleagues after work, see Hagihara et al. 2000)

The cultural idea of “Drinking as an Extension of Work” supports the behaviors of wives who accept their husbands' drinking especially in work-related contexts. For some men, drinking is not just an extension of work but rather the major part of their work. As described earlier, Tokiko's husband [Case 20], for example, was a member of the sale's division of T-company, who mostly stayed home during the day and left home in the evening. His work was to communicate well with customers and sell the company's product, which was not always

successful. When he could not sell the products he wanted, he often became frustrated and resorted to bad behaviors when he returned home from the business related drinking. The fact that he drank pleasantly with his customers but turned abusive once he returned home suggests his well-controlled behavior while drinking where he was forced to behave cheerfully because of the idea that drinking facilitates human relationships. It was not because he was genuinely happy when he was drinking with his customers.

For some men, drinking is quasi-mandatory which means they are expected to habitually drink every day with their work-mates at bars. For example, Yuko's husband [Case 29] worked in such an environment so that she frequently went to her husband's bar by bicycle to pick him up. Yuko commented: "I knew that craftsmen drink a lot. So I simply had to accept it. It couldn't be helped." Another example of the quasi-mandatory drinking can be seen in Makiko's husband [Case 27] who drank every night at a bar with his colleagues where they discussed new projects etc. Every evening, as a privileged white-collar worker (journalist), he came back home from a bar by taxi using the taxi ticket provided by the company. The ticket was officially not supposed to be used for such occasions, but he and his colleagues did it anyway.

Based on the cultural idea "Drinking as an Extension of Work," men are sometimes forced to participate in work-related drinking parties. They go to drinking parties while complaining, e.g., "I don't want to go there, but I have to..." Because of this, there is sometimes an appreciative attitude by their wives and children: "Thank you for making such an effort (=going to a drinking party) to support us as the breadwinner of the family." The wives' generally tolerant or encouraging attitude towards their husband's drinking in the work context adds a positive implication to the behaviors of men's drinking, which in turn deemphasizes the negative aspects of men's drinking in Japan.

A5 Cultural Idea of “Drinking is the Means of Releasing Stress”

According to the Prime Minister’s Public Relations Office (1989), male drinkers’ most common reason for drinking is “to cure one’s tiredness (50%)” followed by “to facilitate human relationships with friends and group members.” This underlines men’s tense working environment and the need for relief of tension. It is notable from the case studies that many interviewees’ husbands grumbled while drinking at home, and Japanese people regard this as releasing stress.

The Cultural Idea of “Drinking is a Means of Releasing Stress” contributes to the tolerant attitudes of wives who permit their husbands’ drinking. Some wives behave attentively while their husbands are drinking in order to avoid conflict. For example, Sakura’s husband [Case 11] drank after work to release stress. He was the manager of five cake shops which put him into a tense environment. Nobody in the family, including Sakura, seriously considered his drinking as problematic, but rather a treat which he deserved as the breadwinner of the family. While her husband was drinking, she was also careful not to accuse him for drinking too much. Akiko’s husband [Case 12], too, was a hardworking man who drank excessively to remove his tension after work, which did not appear as a problem to his family members. Akiko prepared various relish dishes for her husband’s *banshaku* [drinking with meal] and provided a pleasant atmosphere for this occasion every evening. Such an attentive attitude contributes to the general trend where drinking problems are well tolerated or hidden in society.

A6 Japanese Criteria of Alcoholism

Japan’s permissive attitude towards drinking and drunks shapes the criteria of “problem drinkers (alcoholics)”. The stereotypical attributes of alcoholics in Japan are: no stable job, unemployed, blue collar worker, violent, saying senseless things, dirty, smells like alcohol,

carrying alcoholic bottles, homeless, etc. Although these attributes apply to the last stage of alcohol dependence syndrome and do not depict the real picture of many people with alcohol dependence syndrome in Japan, many Japanese believe that this characterization correctly depicts alcoholics. Many Japanese heavy drinker's personal lack of these attributes contributes to their wives' perceiving their husband's drinking as not problematic (or not alcoholic), which in turn prolongs their suffering and delays proper intervention (e.g. medical treatment) for the husband's alcohol problem. In the case studies, many wives regarded their husbands as not alcoholic, because the Japanese stereotypes of alcoholics did not apply to them. For example, Fumiko [Case 18] stated that her husband is not an alcoholic despite the fact that he was diagnosed with various kinds of alcohol-related physiological problems: hyperlipidemia, diabetes, urisemia. Nami [Case 30] did not think her husband was an alcoholic. This was because to her, an alcoholic is like his father who chronically drank a lot and became physically abusive. Considering the severe and chronic suffering of the wives, the societal misunderstanding of alcohol dependence is one of the major obstacles for the treatment of alcohol dependence in Japan.

As described in Chapter 2 [theoretical orientation], the Japanese criteria of alcoholics are also significantly influenced by the androcentric drinking culture and moreover the profit-oriented system. It is noteworthy to see how these criteria are loosely defined in a certain way so that they work disadvantageously for women yet strictly defined on the other so that the capitalist system does not lose much from it. As shown in the case studies, many women suffered from drunken husbands, but people, even the suffering wives themselves, did not consider their husbands as alcoholics. For example, although Takako [Case 13] suffered agony from her husband's alcohol related problems for many years, she did not consider him an alcoholic and therefore did not take any measures against his drinking for a long time. On the other hand, when his boss told Takako that her husband had a drinking problem, she agreed to it and readily took

her husband to the hospital. The boss' idea was based on the fact that Takako's husband missed work without notice several times. "Abusing one's wife for several years is not a problem; however causing a few incidents at work is a problem" is the current criterion of alcoholism in Japan.

A7 Wives' Lack of Knowledge about Alcohol Problems

The society's permissive drinking culture also shapes the perspectives of drinkers' wives who become tolerant of their husband's drinking and simply endure their husband's alcohol related problems. These days, due to the introduction of the concept of "co-dependence," many alcohol specialists encourage wives to not tolerate their husbands' drinking. Due to this intervention program for alcoholics' wives, there are many wives at self-help groups who speak out about how much they were enduring their situation and how wrongly they were cleaning up their husband's alcohol related mess. For many women who lack knowledge about alcohol problems, already learning 1) the nature of alcoholics who are likely to be in denial and 2) the idea that supporting such husbands is rather counterproductive, helps prevent many years of suffering. For example, Saki's [Case 15] husband justified his drinking by saying that his doctor permitted him to drink again. This is a typical example where an alcoholic manipulates the doctor's words to justify his drinking. [Another typical excuse I observed among alcoholics is: "The doctor told me that a little bit of alcohol is rather good for my disease."] If Saki had recognized this as part of an alcoholic's denial and reacted firmly based on her understanding that her husband was in denial, she may have been able to prevent the subsequent suffering (her husband's alcohol problems have been going on for more than 25 years and are still continuing now). Doing this is difficult, but that is what women's self-help groups are for. A women's self-help group is the place where members teach each other in what various ways husbands show

their denial and how one can counteract such behavior. Women becoming knowledgeable of the disease—alcohol dependence syndrome—I believe, is the key, the most effective and efficient way towards the solution of the necktie-alcoholism problem in Japan.

2) Kinship and Gender

As described in Chapter 2 [Theoretical Orientation] using Jack Gody's theory, this dissertation's argument is based on the idea that the old household system, which involves various cultural norms related to marriage, inheritance, and gender roles, is also the product of the profit-oriented-capitalist-system.

B1 The Cultural Understanding of Marriage (Marriage is a Duty, not a Pursuit of Happiness)

The following article 24 of the Japanese Constitution from 1947 was created by B. Shirota Gordon who spent her early years in Japan. Her childhood experiences were her motivation for changing the customs dominated by the legal household system when writing article 24 (Doi and Gordon 1996).

(1) Marriage shall be based only on the mutual consent of both sexes and it shall be maintained through mutual cooperation with equal rights of husband and wife as its basis.

(2) With regard to choice of spouse, property rights, inheritance, choice of domicile, divorce, and other matters pertaining to the family, laws shall be enacted from the standpoint of individual dignity and the essential equality of the sexes.

Despite the current legal state established more than 50 years ago, many people still have difficulties pursuing these rights, which suggests how deep the old household system is rooted in Japanese society.

One of the cultural ideas associated with marriage is that marriage is a duty, and not a means of pursuing one's own happiness. This idea is predominant among many wives, often already before their marriage, and contributes to the future problems where a wife does not recognize her husband's alcohol problem as a problem. Under this cultural idea, women marry a man despite their own desire. In the case studies, there were many wives whose marriage was arranged, which suggests the cultural consensus in Japan that marriage is fundamentally separate from love. Nobuko's marriage [Case 14] was arranged without her consent. She got married twenty days after she met her husband for the first time. This cultural idea of marriage contributes to the creation of wives who are numb to their women's rights and so endure various difficulties as wives. Arranged marriage is only the beginning. When married, a woman's duty as a wife is to support, adjust to and endure her husband. In Akiko's house [Case 12], it was her mother-in-law who usually listened to Akiko's husband's grumbling when he was drunk. However, now that her mother-in-law has passed away, it is Akiko's role to listen to his grumbling. Likewise, there were many women who sacrificed their free-will for the family they had married into but who felt they were never appreciated by that family. Ruriko [Case 1], for example, could not tolerate such harsh treatment by her husband's extended family any longer and decide to divorce. She was permitted to do so but was also told to leave the children. Ruriko stated, "When I was told so, I

felt as if someone splashed me with water and so I woke up and felt the reality. Then, I thought about killing myself. But I couldn't." Many wives are passive toward and so endure their husband's drinking problems because of their culturally induced tolerant character toward their husband. This tolerant wives' gender role, in turn, contributes to the necktie-alcoholism phenomenon which exists without being noticed on a societal level due to the infrequent complaints by wives.

In Table 2, although most wives appeared to possess such attitude already before their marriage, only wives who explicitly expressed so (e.g. wives who believed "women are supposed to get married" or who married through arranged marriage) are colored in black.

B2 The Cultural Expectation for a Wife to Live with and Take Care of Her Parents-in-Law

The cultural expectation for the wife to live with and take care of her husband's parents often induces the wife vs. mother-in-law conflict. When there is a mother-in-law problem, conflicting demands are put on the husband which increases his stress and may become a cause of his excessive drinking. For example, Ruriko [Case 1] said that her harsh relationship with her mother-in-law contributed to her husband's excessive drinking.

The mother-in-law problem also contributes to Japanese men's alcoholism problem in a different way, because when a wife cannot gain support from her husband, she can only tolerate the situation. Ruriko was one of those who did not receive much support from her husband. Rather, she was punched or thrown off from a motorbike when she complained to him about her mother-in-law. She complained about her situation but there was no solution to her problems. She is currently hard working breadwinner of the family, as well as the caretaker of her alcoholic husband.

A wife's psychological burden caused by the mother-in-law problem significantly depends on the reaction of her husband who may or may not support his wife. When the husband is unreliable or not supportive, children may get involved by becoming the main recipient of their mother's complaints. This child-mother relationship significantly influences the children's character as they grow older and may create a co-dependence problem for the children.

In Table 2, cases which have/had mother-in-law problem are colored in black.

B3 Cultural Expectations towards Women

In the old *ie* (household) system, the continuation and prosperity of the male line was the basic principle in the household-oriented society. This ruled various aspects of people's lives including the roles of men and women. Considering women's roles, contemporary society expects women to be obedient to men (in particular to their husbands), non-opinionated, caring, considerate (*ki-ga-kiku*), inferior to their husbands in terms of social status and education, etc. These expectations towards women achieve continuation and prosperity of the *ie* by subordinating the women to it. Although the *ie* laws were abolished more than 50 years ago, many people still follow the rules of the Japanese *ie* system. In the case studies, many interviewees conformed to this *ie* system's idea of womanhood. For example, Mitsuko [Case 21] was a teacher of flower arrangement. She also organized her domestic work perfectly. While she was well appreciated for her ideal womanhood character at the beginning of her marriage, her husband started to take advantage of her as time passed. One day, her husband told her to apologize to a guest for stepping on the guest's futon bed which she had done before the guest had arrived. Mitsuko commented that the reason why he made her apologize was probably because he wanted to show off how traditional and wonderful his wife is.

The expectations towards women create a situation where domestic problems do not reach a critical level when they would be noticeable to an outsider, which contributes to problems being hidden on a societal level. For example, Misaki [Case 2] was a *ki-ga-kiku* (considerate) wife who was careful not to interfere in the first place, therefore serious problems did not occur. She was careful about her words when she wanted to stop her husband's excessive drinking. Instead of saying "Stop drinking," she mildly said "Did you have enough? Don't you want to call it off for today?" Because of such behavior, although Misaki was distressed inside due to her husband's excessive drinking, there were no serious verbal fights between her and her husband. Another example can be seen in the obedient (or inferior, or un-opinionated) wife Akiko [Case 12] who refrained from complaining despite her discontent, therefore serious problems did not occur. Akiko never grumbled or vented her anger about her mother-in-law to her husband even though this was a significant agony in her life. Instead, she worked harder and tried to improve herself so that no further complaints were directed to her by her mother-in-law.

B4 Cultural Norms that Prevent Women from Becoming Financially Independent

In Japan, there are cultural norms that prevent women from becoming financially independent. The following, to name a few, are trends in Japan which discourage women from pursuing careers: higher education is not encouraged for women; most women's highest education is junior-college (2 year college) which is considered *hanayome-shugyo* [training to become a good wife]; women have difficulties finding a rewarding or challenging job; women are in general excluded from the promotion ladder which is available to men; women get paid less for the same work compared to men; women are expected to quit their job upon marriage or the birth of the first child; most women return to the workforce as part-time workers with lower salary and less benefits compared to full time male workers (Smith 1987, Buckley 1993, A Letter

from Japanese Women Circle 1994) In these circumstances, it is difficult for many wives to live without depending on the financial support of their husbands. For some housewives, this engenders a sense of inferiority expressed through comments such as “I am being fed” and/or “I can’t do anything except for housework” which enforces the husband-wife vertical relationship [Case 11].

The cultural norms that prevent women from becoming financially independent create financially insecure women who do not have any alternative to enduring their problematic situation. For example, Masako [Case 7] endured her abusive husband for a long time. She was physically abused, but what hurt her the most were his words: “Give the bank book [book for the bank account] to me.” Although she was generally an opinionated woman, she could not express her complaints in front of her husband. Her attitude was largely based on her inferiority to her husband who made her feel that she was being fed by him as a financially dependant wife. Her sense of inferiority expressed in comments such as “I was being fed by him” or “without him, I cannot do anything.” became the major topic she discussed with her psychiatrist afterwards. In another case, Noriko [Case 9] suffered from her alcoholic husband who was in denial. She regretted that she did not put much importance on education in the past. She also expressed that if she was like her husband who has a stable job, she would not feel as miserable as she does now. Her husband verbally abused her by degrading her, which is a typical behavior of alcoholics who want to keep their wives under their control.

The cultural norms that prevent women from becoming financially independent also induce a situation where they cannot divorce or live separated from their troublesome husbands. There are countless cases of *kateinai-riikon* [divorce within the household] couples where the wives maintain the legal married status but do not have any intimate relationship with their husbands. They stay with him purely for the sake of his income.

B5 The Culture of *Uchi* (inner, inside the house) and *Soto* (outer, outside the house)

(Cultural Idea of Avoiding Shame)

Violence within a household is likely to be unnoticeable from the outside. This is because the family is a unit; the husband's problem (e.g. alcohol problem) is the family's problem which involves the wife's and the children's shame. Therefore, people are unlikely to seek help from the outside. Due to this, social institutions lack the opportunity to help, or, even worse, their staff lack the proper training and information to help these people. This is an obstacle for understanding the nature of domestic problems in general, which applies to this study of understanding necktie-alcoholics' domestic problems, too. For example, although Kimiko's family [Case 10] was respectable [or financially wealthy] family and did not appear problematic from the outside, this couple had domestic fights which extended to the level of calling the police. One day, when the police arrived, her husband changed his attitude completely and behaved calmly. Since he did not appear abusive to the policemen, the police decided to leave which Kimiko did not want. She stated that the policemen's reaction was inappropriate since they did not understand the possibility of her husband flying back into a rage once the police left the house. With more understanding of family problems such as this, such reactions by the police can be replaced by better ways of solving the problem.

Avoiding shame applies to all the wives in this study to some extent. In Table 2, cases where the wife explicitly expressed her intention to avoid shame—"I've never had a chance to talk about our family problem before", "I can't divorce him since it is so shameful."—are colored in black.

Regarding the cultural practice of *uchi* and *soto*, some relatives of a potential groom intentionally hide the candidates' drinking problems to improve the chances of arranging the

marriage. Ruriko [Case 1] was incorrectly told that the potential groom neither drinks nor smokes. This happened because of *uchi* and *soto*, but it was also due to the groom's family's "optimistic" assumption that "If he gets married, he will change and become a decent man. As part of this, he will quit drinking."

It also important to mention the stigma attached to the disease alcohol dependence syndrome and to attending alcoholic self-help groups. Many alcoholic men deny their drinking problem to avoid the stigma of being an alcoholic. Likewise, many alcoholics' wives worry about their husbands' alcohol related problems and/or keenly clean up their mess in order to avoid the stigma of an alcoholic family. Many interviewees in this study showed such behaviors. In addition, many alcoholics' wives also refused to become associated with alcoholic self-help groups because of the associated shame. Kyoko [Case 25] expressed her problem of going to a self-help group. According to her, there are negative images (e.g. bottom of the human hierarchy, bad, human trash) attached to the words "alcoholic" and "*danshukai*" [a self-help group network in Japan, similar to Alcoholics Anonymous]. And these are the obstacles that prevent her from admitting that her husband is alcoholic and start going to a self-help group.

Also note that one of the reasons for *kateinai-rikon* (divorce within the household) is to avoid the shame associated with public divorce.

B6 Lack of Communication between Husband and Wife (Lack of interest in husband's behavior)

Lack of communication between husband and wife leads to the wife's lack of interest in her husband's behavior. This contributes to the situation where the wife does not notice her husband's alcohol related problems. Various cultural factors contribute to the situation where

there is insufficient communication between husband and wife in Japan: a husband living distantly alone as a business bachelor [Case 25], a wife working outside [Case 10], *kateinai-rikon* (divorce within the household) [Case 6], etc. As an example of *kateinai-rikon*, Takako [Case 14] said there was almost no conversation between her and her husband at the time when his disease worsened to the level of madness. The same can be said for Tomoko [Case 6] who neither cooked nor did the laundry for her husband. Because she did not care, she did not know how much her husband was drinking either. The trend in Japan for men to get so involved in their outside work that their position at home diminishes to the level of almost vanishing can be the cause of *kateinai-rikon*, too. In Japan, fathers are sometimes addressed as “*ano hito* [\approx that guy],” “*uzattai* [young people’s slang: dowdy, stuffy, makes you irritated, annoying, obstructive],” “*nureochiba* [wet, fallen leaves which cling irritatingly to the ground and are hard to sweep away]” “*sodaigomi* [a big piece of refuse which is difficult of dispose of]” by the other family members, which suggests fathers’ unpopularity at home in Japan.

G1 Increased Tolerance to Hardship: “I have experience much worse than this (= husband’s alcohol problems)”

In general, people, as they experience suffering, increase their tolerance towards hardship. For those who have gone through many difficulties, a less problematic situation appears as “not a problem” and/or “this is nothing compared to the harsh problem I experienced in the past.” The same applies to some women who went through great difficulties in their past (e.g. harsh experiences during WWII, parents’ alcohol-problems, mother-in-law problems, difficulties taking care of their parents-in-law, problems due to one’s low standard of living), and who then do not regard their husband’s alcohol related problems as significant problems. For example,

Kanae [Case 22] did not consider her alcoholic husband problematic despite the fact that he had repeated alcohol related hospitalization. This was because the distress caused by her senile father-in-law was much more problematic than her husband. In addition, this father-in-law was also an alcoholic and had much worse alcohol-related problems than her husband.

Dysfunctions of Functional Cultures: Cultural Factors that Contribute to Men's Excessive Drinking

This section enumerates and briefly explains dysfunction of functional cultures that contribute to the alcoholics' excessive drinking.

1) *Inshubunka* (Japanese Drinking Culture)

The same cultural factors that contribute to the Phenomenon of Wives Tolerating can also contribute to husbands' justifying their excessive alcohol consumption. In Table 2, whenever these cultural factors apply to the husband's excessive drinking behaviours, they are colored in black. These cultural factors, as they apply to the husbands, are listed as: C1 *Banshaku* culture, C2 *Yopparai Tengoku* (Heaven for Drunk) Culture, C3 Culture that Associates "Alcohol/Capable Drinker" with "Men/Masculinity", C4 Culture of "Drinking as an Extension of Work", C5 Culture of "Drinking is a Means of Releasing Stress", and C6 Japanese Criteria of Alcoholism.

C7 Husband's Lack of Knowledge about Alcohol Problems

While the permissive drinking culture prevents wives from recognizing their husband's alcohol problems, it also helps alcoholics to deny their alcohol problems. Many Japanese heavy

drinkers do not give up their drinking habit despite the fact that they suffer from alcohol related physiological symptoms (e.g. liver disorder, diabetes, hyperlipidemia). This is due to their misunderstandings concerning alcohol dependence syndrome which has certain stereotypes. The behavior of denying ones own alcohol problems can be due to a symptom of alcohol dependence syndrome

2) Kinship and Gender

D1 Responsibilities of the First Son as the Successor of the Household

The responsibilities placed on the first son as the successor as head of the household can be the cause of his excessive drinking. In Japan, where the continuity of the household used to have high importance, the first son is generally the successor of the house. In the traditional *ie* [household] system, the successor also used to be the only heir of the property.

These days, where many practices of the *ie* system still remain, a first sons is usually raised to become a responsible person. He is, for example, expected to take care of his parents and destined to take over his father's business regardless of his own desire. In addition, the successor's role conflicts with some people's future potential. Haruko [Case 3] explained that one of the reasons for her husband's excessive drinking was his predetermined destiny as the first son, who had to give up his dream for his life and carry on his father's business as chef in a Japanese restaurant. Often he drank and complained about his status as a first son and attacked his father. The expectations from parents and the predestined life can become oppressive, boring, and not worth living for some first sons. The customs associated with the first son's role should not be neglected in understanding the situation of first sons who suffer from alcohol dependence.

While this study did not intentionally pick wives whose husbands were firstborn sons, 26 out of 30 husbands were first sons or were carrying the responsibilities as the heir (e.g. living

with his parents). In the Table 2, the cases where the wife explicitly expressed that her husband's drinking is related to his role as the heir of the household is colored in black. In the interview data, husbands who are first sons are under the pseudonym of Ichiro (a common name of first sons in Japan). Husbands who are not first-born sons but are playing the role as the successor are under the pseudonym of Taro (a common name for males in Japan).

Before the abandonment of the *ie* system, being the successor meant inheriting most of the property, as well as the authority over other family members. The successor's advantages however diminished as the *ie* system was abandoned and the society transformed itself from an agricultural society to an industrial society. Now all children (including non-successors) have rights towards their parents' property. Disruptions of the family due to quarrels over the inheritance commonly occur in Japan and this creates bad relationships among siblings, so that an alcoholic's wife has difficulties in gaining support from her husband's siblings. This is the case for Ruriko's family [Case 5] where she cannot obtain the proper support from her husband's siblings.

It is also important to mention the influence of a dysfunctional family on the first child. When the firstborn son is brought up in a dysfunctional family, the life of this child becomes even more burdensome than it already is since there is a great chance that he will become the listener and care taker of his mother. The first child is vulnerable to becoming the listener to his/her mother's complaints in general since he/she is the oldest and has a better ability to understand the problem than the younger siblings. The unstable character of Shizuyo's first son [Case 5], who had a harsh relationship with his father, was probably affected by being a dysfunctional family's first son.

D2 Cultural Expectation for a Wife to Live with and Take Care of Her Parents-in-Law

The mother-in-law problem can become a serious long term problem between husband and wife. The mother-in-law problem can place the husband in a difficult position which increases his stress and his dependence on alcohol. For example, in case 1, Ruriko believed that the hostile relationship with her mother-in-law contributed to her husband's excessive drinking. She expressed that her discontents toward her mother-in-law led to her husband's abusive behavior against her, too (e.g. thrown off a motorbike, punched in the stomach). Despite the fact that she was responsibly playing the role as the first son's wife, her behavior was just not ideal enough for her husband.

Misaki's case [Case 2] is a special case where her role as caretaker of her own mother led her husband to drink excessively. Even though the cause stems from a modified version of the responsibility to take care of one's parent-in-law, D2 is colored in black for Misaki's case.

D3 Expectations towards Men (Stress from Work, Stress from the Responsibilities to Provide for the Family)

Men's social expectation to be breadwinners of the household makes them vulnerable to work-related-stress. This stress can also be caused by problems related to human relationships at the workplace, promotion, a heavy workload (Kawakami et al. 1993), etc. Since their problems are not easily solvable by simply quitting the job, this induces men to grumble about their work while drinking at home and/or at bars. For some alcoholics, work-related-stress is the cause of their habitual excessive drinking. Makiko's case [Case 27] is an example that illustrates this. Makiko's husband was a journalist who was a capable and dedicated worker and who was also

keen on climbing up the promotion ladder. He drank especially excessively around the time when the company decided promotions and relocation for the employees. Whenever work related things did not turn out right, he drank and grumbled. Makiko regarded her husband's careerism as "problematic" and questionable (e.g. "Is he all right?") instead of attractive. She also considered such grumbling behavior "unmanly" and "shameful." This was the case since she believed "Men need to do their work without any complaint." This career-oriented man, however, quit work several years before the expected retirement time due to problems he does not reveal, not even to his wife. During this period, his alcohol consumption also increased significantly. Until now, he denies anything from this company by refusing to open any letters from them. Occasionally Makiko asks what had happened at his workplace but her husband is always silent regarding this matter.

D4 Masculinity (Men's Level of Education)

Japanese society places great value on one's level of education, perhaps more than on one's real abilities. In such an environment, people in their minds maintain a precise ranking of others' level of education, such as the highest degree obtained and at which institution it was obtained. This is used as an indicator for estimating the value of the person in the society. The seriousness of this idea is reflected in some of the commonly heard Japanese phrases which show Japanese people's obsession with attaining academic qualifications:

- *Juken-jigoku*: Conjunction of *juken* (preparation for entrance exam) and *jigoku* (hell) which portrays the life of *juken* as being similar to living in hell.

- *Juken-sensou*: Conjunction of *juken* and *sensou* (war) which portrays the life of *juken* as being similar to struggling in a war.
- *Kyoiku-mama*: Mothers who are obsessed with their child's education, perhaps more than the child him/herself.
- *Juken-noiroze*: neurosis caused by *juken*.
- *Ronin*: It originally meant masterless *samurai*. In contemporary Japan, however, it means a high school graduate who failed to enter a college and is waiting for another year, studying to attempt the entrance examination again (school-less student).
- *Kakure-ronin* (hidden-*ronin*: a university student who failed to enter the desired school but was accepted at a school whose exam was taken as a safety measure. He is secretly preparing for the desired school's entrance exam of the next year while going to the admitted school in the meantime).

The strong hierarchy among schools also induces a trend in society where many people who are not graduates of a top university to some extent have an academic inferiority complex. This trend is especially prominent among men. Some men have this inferiority complex throughout their lives and use their inferior academic background to explain their failure to attain the ideal job or be promoted. (Kawakami et al. 1992.) For Nobuko's husband [Case 14], the cause of his depression was his sense of inferiority as a non-university-graduate which happened when he was appointed to a responsible position of a project as a civil engineer at a construction company. As opposed to him, all other people who were assigned to the same position as him were university graduates. Nobuko said, "I am sure he had his pride. At the same time, however, he might also have felt that he couldn't keep up with their intelligence. He couldn't sleep at night, suffered

from insomnia, and became depressed.” This man eventually attempted suicide by jumping from the roof of eight floor building.

D5 Masculinity (Cultural Value of Men with Few Words)

In contrast to the cultural perception that derogates women as being “the talkative gender” or “gossip loving gender,” “men with few words” are perceived as ideal in Japan. This cultural idea makes it difficult for men to express their feelings and needs freely compared to women. Men are vulnerable to stress in this sense. In this study, there were many taciturn men who “became talkative when drunk” or “could not talk without the help of alcohol.” For example, Tomoko [Case 6] stated that her husband is a taciturn person who doesn’t reveal his heart. Haruko [Case 3] also stated that her husband is when sober such a quiet person that it would be better if he talked even half as much when he is sober compared to when he is drunk. These men, according to my hypothesis, are repressing themselves on an unconscious level when they are sober. Alcohol then allows them to release their repressed feelings. The same argument can be made for men who change their behavior significantly when drunk. In this study, there were many men who appeared to their wives to be are very quiet when they are sober.

D6 Masculinity (Cultural Expectation of Men Repressing Their Amae)

Because of their structural superiority, men must be economically, physically, and intellectually dependable for their wives and children. These duties make men vulnerable to mental stress. In this society, the ill-mannered amae-behaviors are not permitted for men: they want to complain but they cannot; they want to sulk but they cannot; they want to cry out but they cannot. In these circumstances, some men release their bottled-up feelings by indulging in alcohol—a common way of releasing stress. My investigation of Japanese alcoholics at self-help

groups demonstrated this culturally based gender role where men must socially restrain their *amae* in public (Kato 2000, Saito 1995, 1996). The Japanese feminist movement is mostly concerned with improving the structural discrimination against women, not the mental discrimination against men. To improve gender equality in Japan, people must therefore also consider improving this psychological imbalance, which is restraining men's lives.

In Table 2, cases where wives explicitly stated *amae*-related reasons for their husband's drinking are colored in black: "He is *amaenbo* (\approx His is an *amae* pursuer—a baby— inside)," "He is *samishigariya* (He can't stand being alone. \approx He needs attention.)," etc.

D7 "An Empty Life" Due to Retirement and/or Completion of Responsibilities as a Father

Retirement and/or the last child's marriage can become the beginning of men's excessive drinking. Since these are considered the final major tasks of a father in the household, they are also the moments for many men that reduce the tension in their hard-working lives. For some men who have been deeply involved with work until these moments, the empty life without hobbies can lead them to habitual drinking which becomes their sole hobby. (Zen Nihon Danshu Renmei 2003). While there are many older alcoholics of this type in Japan, many doctors dismiss these people's alcohol dependence problems due to the patients' older age and the doctors' understanding that abstaining is extremely difficult for the patients. The outcome of the doctors' lenient attitude towards older alcoholics is devastating when seen from the perspective of the alcoholics' wives who must take care of their husbands, sometimes for decades. For the coming aged society, better understanding of old people's alcoholism is necessary in addition to a change in the lenient attitude towards older alcoholics among general practitioners. Tamayo's case [Case 16] illustrates all the problems described above. Her husband's excessive drinking habit only

started after his retirement. Since he does not violate the Japanese criteria of alcoholism, such as not going to work or having a fight with other people, there was no particularly strong reason to ban his drinking. But because of his excessive drinking habit, he has finally been hospitalized. Tamayo wants her husband to realize his drinking problem and lead a constructive life, but unfortunately, her husband is in denial. She asked his doctor to tell him about his alcohol problem, but according to Tamayo, the doctor does not seriously address his alcohol problem. At the time of the interview, he was hospitalized and Tamayo was worried about her husband who may start drinking right after he gets out of the hospital.

In the interviews, it is noteworthy that some wives permit their husband's excessive drinking during retirement based on an appreciative attitude towards the husband's hard work as the breadwinner in the past: "Since he has made great effort providing for the family, why not let him pursue his enjoyment now that he is retired." This permissive attitude towards their husband's excessive drinking is to some extent related to the expectations towards women to be kind, understanding, obedient, supportive, etc.

D8 Problems in the Husband's Childhood Environment and/or in his "Blood"

There are many scholarly reports on the patterns observed among alcoholic families: "dysfunctional family and/or alcoholism permeate through the family line," and reports that "women who grew up in an alcoholic family are likely to marry an alcoholic man." Some wives of alcoholics believe that the above tendencies are the reasons behind their situations. For example, when I asked Saki [Case 15] why her husband drinks excessively, she said in a determined tone: "It is in his blood. He is from a family that drinks. I can't think of anything else. He liked alcohol since he was born, so he started to drink when he was still young, and therefore became what he is now."

Note that “*Chisuji* [blood]” and “*Kakei* [descent, lineage]” as in “My husband’s excessive drinking is because of his *chisuji/kakei*,” are ambiguously used among Japanese. As the reasons for the husband’s drinking, these words seem to indicate the following situations: 1) the husband is *nomeru-taishitsu* [biologically capable drinker, can drink large amount without losing control]; 2) the husband is *sake-zuki* [alcohol lover, may or may not be *nomeru-taishitu*]; 3) there are several alcoholics in the husband’s family line; or 4) the husband was brought up in a dysfunctional family environment.

Factors Characteristic of Alcoholic Families Worsen the Situation

E1 Wife’s Dysfunctional Family Background and/or Existence of Alcoholics within Her Family Line

While D8 Problems in the Husband’s Childhood Environment and/or in his “Blood” focused on the wife’s perspective of her husband’s family background, this section focuses on the actual conditions of her own family background.⁴⁰ According to various studies of alcohol problems (Black 1981, Schaef 1986), a woman who comes from a dysfunctional family or has alcoholics in her family line is likely to have a co-dependence problem (See glossary “co-dependence”)⁴¹. When the wife is co-dependent, she is likely to take certain actions listed

⁴⁰ It is important to keep in mind that this information is based on the wife’s story and that if she omitted some important fact then it will be missing here and in Table 1.

⁴¹ I follow Saito’s definition of co-dependence where he describes co-dependence as certain traits derived from the person’s dysfunctional family background (e.g. live altruistically to the extent of harming oneself). (See glossary on co-dependence on page 555) Some scholars, such as Sharon Wegsheider-Cruse, define all persons who have one or more alcoholic parents or grandparents, or grew up in an emotionally repressive family as suffering from co-dependence (Schaef 1986). Wegsheider-Cruse’s definition of co-dependence does not allow space for those who grew up in alcoholic or dysfunctional family but do not have what one may call co-dependence traits.

below.⁴² These behaviors are commonly observed among co-dependent wives and are known to contribute to them not recognizing their husband's drinking problems as problems.

- Although she always wished not to become like her mother, she is repeating the life pattern of her mother who was a victim of her alcoholic husband.
- She often endures the situation since she has difficulties expressing her feelings in general.
- She has difficulties establishing an equal love relationship.
- She regards repressing herself and/or sacrificing as the way to show her love.
- She is used to taking care of the husband's problems and regards it as something worth doing (Depends on "addiction/dependency problem." [See glossary "co-dependence" on page 554]).

Nami [Case 30] was a wife who applied to general characters of co-dependence. She was brought up in a dysfunctional family where her father was an abusive alcoholic. She was once divorced and was married to a man who was also once divorced in the past. Nami has been suffering from her second husband who drank a lot but did not take any action to improve the problem. It was her brother-in-law and her parents-in-law who wrote an elaborate letter to a self-help group describing their concern about Nami divorcing her husband. According to her brother-in-law, Nami and her husband have disputes frequently. According to Nami, she does the typical *shirinugui* [cleaning up his mess], such as calling her husband's workplace telling the company

⁴² For more information on co-dependence, see Schaeff 1986, 1987 and Saito 1996.

that he is not coming to work. At the time of the interview, her major wish was for her husband to stop his excessive drinking.

Note that in Table 2, wives who had difficulties because they lacked sufficient caretakers while growing up (e.g. parent died) when they were young are also colored in black.

E2 Husband's Dysfunctional Family Background and/or Existence of Alcoholics within His Family Line

Like in the previous section, this section focuses on the actual conditions of the husband's family background.⁴³ According to various studies on alcohol problems (Schaefer 1986, Black 1981), a man raised in a dysfunctional family or having an alcoholic in the family is likely to have a co-dependence problem. When the husband has co-dependence, he is likely to take certain actions listed below, which become a cause of dysfunction in the next generation.

- Although he always wished not to become like his alcoholic (or irresponsible) father, he is repeating the life pattern of his father.
- Since he has difficulties expressing his feelings in general, he endures or, if he can't, resorts to violence.
- He has addiction problems (e.g. drinking, gambling, drugs, working excessively) which are means of escaping from the harsh reality.

Shizuyo's son [Case 5] was a man who showed to general characters of co-dependence. He was brought up in a dysfunctional family where his father was an abusive alcoholic. He

originally had a very quiet, obedient character, but he started being abusive since his high-school period. Sometimes what he did was is very considerate such as taking care of his mother, but he occasionally flew into a rage and abused other people. He loved, yet also hated, his parents and accused his mother for not taking care of him properly. His is currently unmarried.

Note that in Table 2, husbands who had difficulties because they lacked sufficient caregivers (e.g. parent died) when they were young are also colored in black.

E3 Husband's Being Diagnosed with Mental Illness (E.g. Depression)

Occasionally alcoholics are treated in the name of mental disorders (e.g. depression) instead of under the label "alcohol dependence syndrome." Some alcoholics are hospitalized several times under the label of mental disorders before they are diagnosed with alcohol dependence syndrome. It is also important to note that many heavy drinkers are diagnosed with 'alcohol related disorder' and not with 'alcohol dependence syndrome.' Considering the long suffering of the family, this medical procedure is sometime misguided and misleading. For example, Misaki's husband [Case 2] was diagnosed with "depression"; Tomoko's husband [Case 6] with "depression and mania"; Kimiko's husband [Case 10] with "character disorder/abnormal character." It is known that psychological problems such as the above are closely associated with excessive drinking. However, whether the psychological problems are the cause of alcoholism, or alcoholism is the cause of the psychological problems is not clearly understood.

⁴³ It is important to keep in mind that this information is based on the wife's story and that if she omitted some important fact then it will be missing here and in Table 1.

E4 Strong Denial

One of the commonly observed symptoms of alcohol dependence syndrome is “denial,” that is, denying one’s own drinking problem and insisting on drinking. Denial includes the following behaviors:

- He insists that he is not alcoholic and keeps on drinking. [Applied to many.]
- He tells lies regarding his drinking habit (e.g. He says he drinks 2 *gou* (≈ 0.36 liter ≈ 0.1 gallon) per day even though he drinks 3 *gou* per day.) Since there is a consensus that 2 *gou* is within the realm of *tekisei inshu* (moderate drinking), there are many men in Japan who say that they drink 2 *gou*.
- He keeps on drinking even though he has been advised by a doctor to reduce/stop his drinking. Most men in this study were advised by their doctors to reduce/stop drinking at least once.
- He intentionally abstains several days before the mandatory health examination in order to reduce the gamma-GTP level in his blood. Some men, like Makiko’s husband [Case 27], abstain for a few days before the mandatory health examination in order to reduce their γ GTP level (indicator of liver damage due to alcohol consumption). After the examination, they start drinking again.
- He interprets the doctor’s advice—“Don’t drink” or “Reduce your alcohol consumption”—in a favorable way such as “I can drink a little bit since some drink is actually good for one’s health,” “2 *gou* is acceptable amount”
- He refuses to see the doctor, or refuses to receive treatment for alcohol dependence syndrome. Haruko’s husband [Case 3] hates medical institutions so much that he

stubbornly refuses to see a doctor. Because of this, Haruko has been suffering from her husband's alcohol related behaviors for at least 16 years.

- He becomes mad, resorts to violence, or sometimes even tries to drink even more when somebody criticizes his drinking. For example, in Nobuko's anecdote [Case 14], there was an abstaining alcoholic who resumed drinking because he was degraded by his wife. Just because his wife compared him with her friend's ideal husband, he resorted to drinking again and even worse—he also ate two bowls of *gyudon* which is high in sugar and salt despite the fact he suffered from diabetes.
- Hiding alcoholic beverages in order to secure additional drinks. Ryoko's [Case 26] alcoholic husband hid many alcohol bottles in and around the house. This went to the extent that her husband could not keep track of where he hid the bottles. Her husband has been abstaining for over one year now; however, family members still find bottles that he hid when he was still drinking.

Inadequate Public Support which Worsens the Situation

F1 Inadequate Public Support

Unfortunately, even if a wife recognizes her husband's drinking problem and seeks help from outside, current Japanese public institutions do not provide services to properly support these women. As shown in the interviews, there are many wives who are enduring problematic situations which could be solved if proper support had been available to them.

In the current system, whether wives receive proper support depends on their luck of meeting the right person. Since the public health center is the place where many wives first go to

consult about their domestic problems, it would be helpful if the center were well informed about the available services and specialists (e.g. counselors, doctors, lawyers, social workers) in the community that could meet the wives' needs. These days, some people obtain the necessary information through the internet. The internet is especially helpful for people who seek help but want to maintain anonymity.

Table 3 lists the interviewed wives' wishes for solving their problems. These are not limited to the changes desired on a public service level; some desired changes are on a broader cultural level. By meeting women who cried or unexpectedly showed appreciation to me for listening to their personal stories, I also felt the urgent necessity of emotional support for these women who often did not have any opportunity to talk about their problem. The availability of affordable counseling services and/or non-stigmatized self-help groups are some of the possible solutions to this problem.

While not all wives explicitly stated how Japanese public services should change, all the narratives included a message about the problems in the current system. Based on this, I interpret that they were lacking proper support from public services and therefore apply to the section (801 Lack of Proper Support by the Public) in the Table 2.

Table 3: Wives' Wishes for Solving the Problem

Case	Summary
1	Unavailable
2	<ul style="list-style-type: none"> • The norm of the first son taking care of his parents is a cause of stress. [I wish such a rule did not exist.]
3	<ul style="list-style-type: none"> • I went to the public health center but it was of no use. → [I wish the public health center could support us more.] • I think the hereditary system has a problem. → [I wish the hereditary custom did not exist.] • I wish my husband did not grumble so much.

	<ul style="list-style-type: none"> • I think the “permissive drinking culture” is wrong. • I wish there was a place where I can consult about my husband’s drinking problem casually. (The police station is not a place where one can consult about this problem casually.) • I wish there was a visiting service from a place like the health center, a casual service where one or two men visit the house and cope with the problems when they occur. (Policemen are not the best person to call for such a service.)
4	<ul style="list-style-type: none"> • I went to the public health center but it was of no use. → I wish the public health center could support us more. • I wish my husband did not drink. • I think it is wrong for famous people, such as commentators, idols, comedians, to support the permissive drinking culture on TV shows.
5	<ul style="list-style-type: none"> • I wish the information on alcohol problems was more accessible to us. (Since TV dramas have significant influence on our society, it would be good if we had a TV drama that deals with alcohol related problems.) • Since alcohol specialists’ careless advice based on their deterministic assumption can make the problems worse, I wish them to understand their role as a specialist and give careful advice. • I was ignorant of the trial procedure. → I wish the layer had provided me with more information on what are the possible rights of wives upon divorce.
6	<ul style="list-style-type: none"> • It is troublesome that child-support by the father after divorce is not enforceable. → [I wish it would become enforceable.] (Even if child-support is mandated by the court, the law does not provide a penalty for not paying.)
7	<ul style="list-style-type: none"> • I wish the information on alcohol related problems were more accessible to us in our society. • Since the public health center is the place where many wives consult first, this place should be well equipped with all the information necessary for these women. • I wish the public shelter and counselling are more accessible or more women friendly.
8	Unavailable
9	<ul style="list-style-type: none"> • When I consulted a layer regarding my problems with my husband, the layer pointed out my depressive attitude and stood on the side of my husband. → I wish the layer was more understandable to the abused wife’s perspective. • Since there is stigma attached to alcoholics and their parents in this society, I wish such stigma would be removed. I wish the society would remove the stigma attached alcohol related problems, which prevents people from talking about this issue. • I wish people in general would deepen their understanding of alcohol dependence syndrome.
10	<ul style="list-style-type: none"> • I think there is a problem in our family’s custom of “over-hiding shameful events”, “over-enduring pain”, and the “wife’s role of over-supporting a problematic husband.” • I was discontent with the reaction of the police whom we called when my husband resorted to violence. → I wish the police (or public service) were more understanding and supportive to wives on the occasion of domestic abuse. • I wish there were means of making an abusive husband realize that he was committing a sin, such as making him go to counselling. • I went to the public health center but it was of no use. → I wish the public health

	center could support us more.
11	<ul style="list-style-type: none"> • I wished the doctor told me, not just my husband, about his physiological conditions. • I wished the doctor explained the problem in an understandable manner. • I wish there were better public understanding of the disease alcohol dependence syndrome.
12	Unavailable
13	Unavailable
14	Unavailable
15	• I feel lonely. → Even if he is such a bad husband, I still want to live with him again.
16	Unavailable
17	<ul style="list-style-type: none"> • I wish the doctor let my husband recognize the seriousness of his disease. • I wish the doctor gave precise medical advice to my husband and the rest of the family.
18	Unavailable
19	<ul style="list-style-type: none"> • I wish my husband did not drink too much. • I wish my husband did not grumble while drinking.
20	• I wish alcoholics would think about the feelings of the family, those who were involved in their drinking problems.
21	• I once went to a public marital counselling service, but since I did not have enough time to talk about all my problems, I gave up going there in the end. → I wish there was a place where people could consult about their problems thoroughly in a relaxed manner [without worrying about the consultation fee.]
22	Unavailable
23	Unavailable
24	Unavailable
25	<ul style="list-style-type: none"> • I wish the gender equality would actually occur in everyday life, especially in the way people think, not only on the legal or specialist's ideological level. • There are negative images (e.g. bottom of the human hierarchy, bad, human trash) attached to the words "alcoholic" and "<i>danshukai</i> [a self-help group network in Japan, similar to Alcoholics Anonymous]." I wish those images went away.
26	Unavailable
27	• When I consulted a specialist (male psychologist) about my husband's unfounded accusations regarding an extra-martial affair, he told me: "There is no smoke without fire." → [I wish he, as a specialist, was more understanding to my problem.]
28	Unavailable
29	Unavailable
30	Unavailable

Types of Problems

This section discusses the types of problems (verbal, physical, financial and psychological abuse, cleaning up the husband's mess and child-related problems) occurring in the cases:

H1 Verbal Abuse

The following situations and behaviors constitute verbal abuse:

- The husband says abusive things to his wife such as “You are a worthless woman,” “You can't do anything.” Saori's husband [Case 9] degraded his wife frequently. He, for example, discredited her college degree, saying that it is just an extension of the kindergarten degree. Such husband's degrading may have contributed to her depression problem, too.
- The husband makes his wife listen to his complaints regardless of the wife's willingness. Many women were the listener of husband's complains even though many were not happy listening. Tokiko's husband [Case 20] grumbled in bed and made her listen to his complaints. Sometimes, because of this, she was not allowed to go to sleep. Noriko [Case 9], who was annoyed by her husband's frequent complaints, said she uses ear plugs while she is cleaning or cooking since she does not want to be interrupted by her husband's complaints. She takes sleeping pills to go to sleep.

H2 Physical Abuse

The following situations and behaviors constitute physical abuse:

- Punching (open hand and closed hand), kicking, or pushing other family members.

Some women do not consider themselves a victim of physical violence even though they are severely abused by their husbands. Nobuko's husband [Case 14] was an abuser who hit her with his fist. Nobuko on the other hand said her husband's violence was not so severe and therefore her husband is not an abuser. Ruriko [Case 1] said that her husband was not so physically abusive, but she also said that she escapes and hides whenever her husband starts drinking.

- Hurting other family members with objects. (e.g. cup, soup bowls, stick) Some fights involve lethal weapons such as a butcher knife [Case 5 and 14], a golf club, a baseball bat [Case 5], or a bamboo sword [Case7]. The wife is not always the target of the violence. Sometimes the wife is free from violence while the alcoholic's parents are not. In case of Haruko, it was always her father-in-law who was the target of physical abuse by her alcoholic husband.

- Husband rapes his wife. There were four cases of domestic rape which I encountered during the interviews [Case 6, 7, 15, 19]. Since such a topic is considered very private and I did not intentionally explore this aspect, there is a possibility that many more women are victims of domestic rape than was shown here.

- Venting one's anger on objects (e.g. bang the table, kick the wall, break the window.) During the interview, I occasionally encountered interviewees whose husbands overturned the table. While I have rarely heard about Americans overturning the table or seen Americans doing this in movies, I occasionally hear about and witness such incidents in Japanese people's jokes and TV shows. Overturning a table may be a Japanese cultural practice.

Since physical abuse is shameful, there is a possibility that more extensive existence of this problem was not truthfully related in the interviews. In fact, there was one case where the women stated that domestic violence does not really occur but, according to the person who introduced the interviewee to me, she had experienced serious abuse. According to the introducer “the alcoholic husband strangled his wife with an electrical cord.”

H3 Psychological Abuse

The following situations and behaviors indicate psychological abuse:

- Because a wife worries about her husband’s safe return from the bar late at night, she starts wandering around the neighborhood, can’t go to sleep until he comes back home, feels her heart beating when she hears a car stopping near the house, checks the bars where her husband may be drinking, etc.
- A wife suffers from psychological problems such as sleeping disorder, stress and depression. Saori [Case 8] suffers from depression. She expressed that she sometimes feels suicidal and gets tempted to hang herself in her daughter’s apartment. Noriko [Case 9] also banged pots and pans with lids and utensils and make loud noises to release stress. She confessed that the bottled-up feeling led her to abuse her child, too.
- A wife consults somebody (e.g. counselor, doctor, clerk at health center) about her husband’s alcohol related problems. This dissertation regards such consultation as psychological abuse because this action indicates that the woman is psychologically distressed because of her husband’s drinking. Many interviewees who consulted people

such as a counselor, a doctor, or a clerk at a health care center showed that they were significantly discontent about their abusive husband. Makiko [Case 27] went to a psychologist to consult about her husband. She was desperate. Unfortunately the psychologist was a scholar who does not specialize in curing people's problems and thus did not give proper advice. When this happened she lost hope. Makiko was so depressed that she thought of killing herself by jumping off a tall building.

H4 Financial Abuse

The following situations and behaviors constitute financial abuse:

- A husband does not give money for the household expenses to his wife. For example, Masako's [Case 7] husband told to her to give him the bank check. This gave Masako mental stress about which she consulted a doctor later. When Kyoko [Case 25] was upset about her husband who was drinking excessively, she complained to him, "You shouldn't be drinking like that! What do you think we are?" He replied, "You are just my dependents. So shut up!" This man degrades her voluntary work as a case worker, saying things like, "If you have so much time for such nonsense that doesn't make any money, do weeding in our yard instead."
- Since the husband is financially unreliable, the wife goes out to earn money for the household herself. Tomoko's husband [Case 6] did not provide sufficient money for the household expenses. He used it for his own entertainment, such as going drinking, going to the red-light district, or having an extramarital affair. Tomoko, who can no longer financially depend on her husband, started to work at a flower shop.

H5 Cleaning Up the Husband's Mess [*Shirinugui*]

In the field of alcohol treatment, a wife cleaning up her husband's mess is considered a bad (must-not) behavior because it burdens the wife while shielding the husband from the problem and feeling its effects. The following situations and behaviors apply to Cleaning Up the Husband's Mess [*Shirinugui*]:

- A wife goes to the bar to pick up her drunk husband. Kyoko [Case 25], whose husband often slept in public places, was frequently called to pick him up. One day, she saw a police car around a rice field where neighbors were gathering to see what was going on. Kyoko found out that the incident was caused by her husband sleeping in the middle of the rice field. She was embarrassed.
- A wife compensates the victims of her husband's drinking problem (e.g. She apologizes to the husband's boss with whom he fought the previous night, to the bar for breaking equipment, to the opponent of the fight who was injured.) Because his boss was not properly doing his work, Misaki's [Case 2] husband complained about it, lost his temper and flung a glass at him, which led to a struggle. The next day, carrying her child on her back, Misaki went to the superior's place and apologized for her husband's action.
- A wife calls her husband's workplace and to tell that her hung-over husband cannot come to work. [Applies to many wives.]

H6 Child-Related Problems

The following situations and behaviors show Child-related problems:

- Parents (not necessarily only the husband) abuse their child excessively. Because Tomoko [Case 6] was distressed due to her abusive husband, she one day found herself pointing a kitchen knife at one of her children. Misaki [Case 2] also confessed that she struck and kicked her children. Her mother told her that she looked as if she was bullying her children instead of disciplining them.
- A child has juvenile delinquency problems. Sanae's second son [Case 5] had juvenile delinquency problems. He became a member of a motorbike gang and dropped out of high-school.
- A child has an eating disorder (often for females). Saori's daughter [Case 8] has an eating disorder and also suffers from depression.
- A child is unwilling to go to school. Akiko's [Case 12] son refuses to go to school.
- A child has *hikikomori* (shutting oneself in) problem. Tomoko's [Case 6] daughter started not to go to school when she was 14 years old. She is mostly confined to her house. Counseling is not improving the situation at all. She has attempted to commit suicide too. Considering the fact that she is now 21 years old, she has been doing *hikikomori* for seven years.
- A child has depression related to his/her dysfunctional family problem. All of Saori's children [Case 8] have depression problems. Saori believes they are all rooted in the harsh relationship between her and her husband.

- A child has a hostile relationship with his/her parents. Sanae's first son [Case 5] has a chronically harsh relationship with his parents, especially with his alcoholic father.

Analysis Conclusion

Early intervention by public institutions is not the only solution to the problem of there being so many necktie-alcoholics in Japan. The problem also requires a better understanding of "Why do wives not recognize the problem?", "Why do wives bear the problems?" and "Why do many men become alcoholics?" There are various cultural factors—e.g. a drinking culture and gender related cultural issues that are rooted in the Japanese family system—which contribute to the current phenomenon. And the characteristics of alcoholic families (e.g. alcoholics' symptom of denial or wives' symptom of co-dependence) and the lack of proper public support make the problem worse since they make it even more invisible. This induces a situation where the family members—especially the wives—tolerate the problem until they reach *donzoko* [the very bottom], which commonly takes many years. The solution to necktie-alcoholism therefore also depends on a change in culture to which social institutions as well as individuals, especially the wives, can contribute.

CHAPTER 5. CONCLUSION

This study investigated the lives of alcoholics' wives in the context of Japan where only one percent (23,800) among the 2.4 million heavy drinkers receive proper medical treatment for alcohol dependence syndrome. No significant measure has been taken to improve this situation since there is a general consensus that these heavy drinkers are *shizuka-na-aruchu* (quiet alcoholics) who are not harmful to the society. It is possible that some quiet alcoholics do exist. However, it was shown here that many of these heavy drinkers can also be abusive, which does not agree with the general social impression in Japan. In addition, this study reported that many heavy drinkers who do not cause serious alcohol related problems (e.g. resort to violence) and are therefore considered "non-problematic" are not necessarily problem-free. Sometimes the problems do not occur simply because their wives are cautious in their behavior in order to not trigger problems with their drunken husbands. There are also many cases where the situation appeared problematic from an outsider's perspective but was considered non-problematic by the wives because they were conditioned to tolerating this situation. Based on these findings, the current Japanese criteria of problem drinker (alcoholic) are irrelevant: they are too lenient for male drinkers and overlook the problems caused from this permissiveness which can harm others, especially the drinkers' wives.

This study also analyzed the reasons for necktie-alcoholism being unrecognized in Japan. There are various intertwined cultural ideas and norms—androcentric and profit-oriented Japanese drinking culture and other cultural norms that are not apparently related to drinking at first glance (e.g. kinship and gender patterns)—that contribute to the phenomenon where men drink excessively or wives tolerate alcoholic husbands. Since these cultural ideas and norms are usually perceived as socially functional but have negatively affected the individuals in the

particular cases, this dissertation called these cultural elements “functional cultural practices that have dysfunctional side effects.” This dissertation also discussed the problematic aspects of these elements, such as the problems in *banshaku* [drinking with supper] cultural practice, *yopparai tengoku* [heaven for drunks] cultural practice, cultural expectations towards women, and cultural expectations towards men. This discussion showed the diverse cultural problems involved in necktie-alcoholism, as well as suggested that merely cutting down alcohol consumption will not solve the problem. On the macro level, examining each cultural aspect and making improvements in the public policy level is the way to solve the problem.

This dissertation also argued that most of these cultural practices, norms or ideas are generated by the profit-oriented-capitalist-system, therefore the real cause of necktie-alcoholism lies there. I posited that Japanese people are caught in a system where the economic mode of production shifted from agriculture to industry. This induced a situation where people simultaneously follow certain responsibilities imposed by an agriculture-based society, as well as those imposed by an industry-based society.

In addition, the dissertation argued that drinking is advantageous to the capitalist system, for it works to tame workers and make them efficient in the public sphere by: (1) strengthening ties between work-mates and (2) releasing stress caused by the state with minimal cost to the system. This works since alcohol—as a drug—provides the “anti-structural” experience, which is crucial for all human beings (Turner 1992), immediately and without failure (Kato 2000).

I also argued that the ideology of the permissive drinking-culture works well to justify these advantages by deemphasizing the dysfunctional aspects of drinking. It works well by having intellectual males, whose value system corresponds well with the interests of capitalist elites, write about how male alcohol consumption is a positive practice in Japanese society. This

idea was so effective that it even influenced the criteria of problem drinker (alcoholic) in Japan which in turn determined the criteria for Japanese alcohol dependence syndrome.

Taking measures on a micro level is therefore as important as, or perhaps more important than, the measures on the macro level. For this, it is important for women to become educated about this issue (education before marriage is preferable) and learn that tolerating the situation is not the means of solving these kinds of problems. Women are tolerating the situation too much. Through the interviews, I felt the serious necessity for women to complain and express themselves more, which is crucial for changing the society. This gives many positive outcomes: regaining a healthy mind, early intervention to the problem, improving the marriage relationship, reducing family stress, and preventing children from having co-dependence problems. This not only brings positive consequences on the individual/family level but also promotes changes on the macro level. Women's voices bring awareness to this problem in society, which can become the driving force to change the society; this has the potential to change public policy, conventional culture, and even the hard-to-change social structure. The necktie-alcoholism problem can be lessened by women advocating for change.

Finally, for the future development of this problem, I speculate that the situation can become either better or worse and that depends on women's reaction to the problem. On a bright note, the Japanese drinking culture [*inshu-bunka*], which has long been known as an "overly permissive drinking culture" (Pittman 1967), has recently started to change. Japan's formerly persistent increase in alcohol consumption has been stagnant or negative for the last few years (Taxation Department, Liquor Tax and Industry Division 2002), suggesting a break in the more than 40 year history of increasing alcohol consumption. A counterforce to the permissive drinking culture is emerging: a movement to increase awareness of alcoholism, COAD [children of alcohol dependence], *ikki* [binge-drinking], drunk-driving, and misleading alcoholic products

and commercials. These are making gradual changes in society. Some cause change on a political level: legislation to regulate the operating time of alcohol vending machines⁴⁴ and increasing the punishment for drunk-driving.⁴⁵ As part of the Japanese Human Rights Movements, which question many customs, Japanese *inshu-bunka* is also facing change, change that brings not only difference in people's drinking habits but also in the way they behave and think.

When seeing the future of Japan, however, one factor that can worsen the situation and therefore should not be overlooked is the problem of the aging society. According to the government's Annual Report on the Aging Society: 2003 Cabinet Office (Cabinet 2003), Japan is about to become a serious aging society: 19% of the total population (24.3 million people) was more than 65 years old in the year 2003 which will increase to 26.0% in 2015 and 33.2% in 2040. This indicates not only the society's lack of work force in the future or raises the question of what these old people do after they retire (e.g. some end up drinking, see D7 Removal of Tension Due to the Accomplishment of Tasks as a Father on page 516), but moreover there is a problem of who is going to support these people on a daily basis. According to custom, old people have been supported by the younger generation by living with them, where young men work outside as breadwinners and their wives take care of their parents-in-law. Could Japan overcome the aging

⁴⁴ Although these are still prevalent, restrictions have finally been made to limit the operating time, which prohibits sales between 11 p.m. and 5 a.m. In order to prevent alcohol consumption by minors, vending machines for alcoholic beverages are now being replaced with ones capable of verifying the age of the customers by scanning their identification card (<http://www.jvma.or.jp/> Accessed 9/10/03).

⁴⁵ The societal attitude towards drunk-driving has also become stricter in the last few years. Due to the amendment of the Criminal Code in 2001, killing someone when driving drunk is no longer charged as "professional negligence resulting in death" (≈ "unintentional" mistake, maximum five year imprisonment) but as "dangerous driving resulting in death" (≈ "intentional" mistake, maximum fifteen years imprisonment) (http://www.ask.or.jp/ddd_topicks.html Accessed August 2003). A verdict by the Tokyo District Court in July 2003 awarded unprecedented high compensation of approximately 250 million yen to the parents of two girls killed by a drunk truck driver at Toumei Expressway in Tokyo's Setagaya Ward on Nov. 28, 1999 (<http://www.asahi.com/english/national/K2003072500377.html> Accessed August 2003).

problem by following this custom? It would be ideal *if* people could do so without causing conflicts and family stress which is commonly present in reality. The conventional family customs rooted in the *ie* [household] system (e.g. first son becomes the heir of the household, his wife lives with and takes care of her parents-in-law) may not be sustainable because it has the pitfalls (or weakness) of being inconsiderate towards certain people, especially women. The aging society problem therefore will bring big challenges to Japanese families—the challenge of whether to follow the conventional customs or not. Since the family customs are strongly related to Japanese gender roles, any change in family life means the potential for significant change in Japanese gender roles as well. And these future gender roles are the factors that determine the future of the necktie-alcoholism problem—it can become either better or worse. Once again, how things will change can be influenced by women; it all depends on what the women will learn and how they will react to it.

REFERENCES

- “A Letter from Japanese women” Circle ed.
1994 Kokuren CEDAW e no counter report [Counter-report to the CEDAW of UN]. Osaka:
Nihon kara no tegami gurupu shuppan. [In Japanese]
- Allison, Anne
1994 *Nightwork: Sexuality, pleasure, and corporate masculinity*. Chicago: The University of
Chicago Press
- Allison, Anne
2005 “Japanese Mothers and Obentos: The Lunch-Box as Ideological State Apparatus.” In
Gender in Cross-Cultural Perspective, edited by Caroline B. Brettell and Carolyn F. Sargent,
pp 310-320. NJ: Pearson Education.
- Bernard, Russel H.
2002 *Research Methods in Anthropology: Qualitative and Quantitative Methods*. 3rd edition.
NY: Altamira Press.
- Bonvillain, Nancy
2001 *Women and Men: cultural construct of gender*. Third edition. New Jersey: Prentice Hall
- Buckley, Sandra
1993 *The Body Politics of “Being-Woman*. In *Postwar Japan as history*. Andrew
Gordon ed. Pp. 347-372. Berkeley: University of California Press.
- Black, Claudia
1982 *It Will Never Happen to Me!* Denver: M.A.C.
- Cabinet Office
2003 *Annual Report on the Aging Society: 2003 Cabinet Office*.
<http://www.op.cao.go.jp/kourei/english/annualreport/2003/03wp-e.html> (Accessed on Aug. 18,
2004).
- Doi, Takeo
1973 [1971] *The anatomy of dependence*. John Bester trans. Tokyo: Kodansha International
Ltd.
- Doi, Takako and Shirota Gordon
1996 *Kenpou ni danjobyodou—kisou-hiwa* [Including gender equality to the constitution—
unknown episodes]. Iwanami Booklet No. 400. Tokyo: Iwanami shoten. [In Japanese]
- Endo, Takuro

1992 Arukōruizonshou ni taisuru ippanrinshou no sekinin [Responsibility of General Physicians Regarding Alcohol Dependence Syndrome: From research on alcohol drinking tendency among inpatients]. In JIM. 2 (3): 260-264 (In Japanese, Abstract available in English)

Evans-Prichard, E. E.

1951 Kinship and Marriage among the Nuer. Oxford: Clarendon Press.

Goody, Jack

1976 Production and Reproduction: A Comparative Study of the Domestic Domain. Cambridge: Cambridge University Press.

Goody Jack

1983 The Development of the Family and Marriage in Europe. Cambridge: Cambridge University Press.

Grant, Marcus

1992 International Perspectives on Alcoholism and the Family: An Overview of WHO Activities. In Alcoholism and the Family. Satoru Saitoh, Peter Steinglass, and Marc A. Schuckit, eds. Pp. 97-116. New York: Brunner/Mazel

Hagihara, Akihito, Kimio Tarumi, and Koichi Nobutomo

SPECIAL ISSUE ON STRESS AND SUBSTANCE USE – Work Stressors, Drinking with Colleagues after Work, and Job Satisfaction among White-Collar Workers in Japan. In Substance use & misuse. 35 (5): 737- 757

Han, Shintaro and Kazuya Kitamura

2001 Puraimarika ni okeru arukorumondai no hindo to sono sukuriiningu no tame no CAGE shitumon no honpou niokeru sousatokusei [Frequency of alcohol related problems in the context of primary care institutions and the relevancy of CAGE questionnaire for the purpose of screening it in Japan]. In The Journal of the Japanese Society of Alcohol-Related Problems. Vol. 3: 91-97 (In Japanese)

Harris, Marvin

1974 Cows, Wars, Pigs, and Witches: The Riddles of Culture. New York: Random House

Harris, Marvin

1985 Culture, People, Nature: An Introduction to General Anthropology. Fourth Edition. New York: Harper & Row

Hanareywa, Takuji and Yoshihiko Komoike

1983 Keshou γ -GTP to Inshuryou to no kankei; shousha ni okeru Shouwa 57 nendo shuuki no seijinbyou-kenkyuu-seiseki kara [Relations between γ -GTP in Serum and Drinking Volume from a Result of Health Examinations at a Trading Firm]. In Sumitomosangyoueisei. Vol 19 (April): 69-73. (In Japanese, abstract available in English)

Hayashida, Motoi

1998 Some Sociocultural Observation on Alcohol-Related Problems in Japan. In *Alcoholism: Clinical and Experimental Research*. 22, No. 3 May Supplement: 162-163

Higuchi Susumu

1995 Wagakuni no arukōru-kanren-mondai no genjyou; Arukōru hakusho [The country's situation of alcohol related problems: alcohol white paper]. Susumu Higuchi ed. Pp:229-253. Tokyo: Koukenshippan

Higuchi, Susumu and Hiroaki Kono

1994 Early Diagnosis and Treatment of Alcoholism: The Japanese Experience. In *Alcohol and Alcoholism*, Vol. 29, No. 4: 363-373

Hsu, Rober C

1999 "Working hours and stress" In *The MIT Encyclopaedia of Japanese Economy*. Pp. 489-491. Cambridge: The MIT Press

Ino, Aro and Takuro Endo

1994 Arukōruizonshou chiryou ni okeru ippan-i to semon-i no renkei – shoukai jirei o toushite [Teamwork between general practitioners and alcohol specialist for the treatment

alcohol dependence syndrome – through the introduction of case studies]. In *Nihonijishinpou* No 3639 (January 22): 43-48. (In Japanese)

Kato, Junji

1989 Sendaishi no ichinaikamutoushinryoujo no gairaikanja no arukōrushou ni kansuru toukeiteki kenkyuu [Statistical study on alcoholism found in outpatients of a clinic in Sendai City]. In *Arukōruiryokenkyuu* [Journal of Studies on Alcoholism Treatment]. 6 (4): 303-310.

Kato, Junji

1994 Arukōruizonshou no hakkenhou to shindan no houkouzuke: naikai no tachiba kara [Management of Alcohol Dependence Syndrome: Earlier detection and initial management of patients in the non-psychiatric clinic]: In *JIM* 4 (7): 610-613 (In Japanese)

Kato, Keiko

2003 Arukorusho no nichibei hikaku – KAST monshinhyo no mondaiten [Comparison between the U.S. and Japanese Alcoholism; Problems of KAST Questionnaire]. In *Hikakubunka-kenkyu* [Studies in Comparative Culture]. Vol 60: 47-57. (In Japanese).

Kawakami, N, T. Haratani, T. Hemmi and S. Araki

1992 Prevalence and demographic correlates of alcohol-related problems in Japanese employees. In *Social Psychiatry & Psychiatric Epidemiology*, Vol 27 (4): 198-202

Kawakami, Norito, Shunichi Araki, Takashi Haratani and Takemitsu Hemmi

1993 Relations of Work Stress to Alcohol Use and Drinking Problems in Male and Female Employees of a Computer Factory in Japan. In *Environmental Research*, 62: 314-324

- Kozu, Junko
1999 International Perspectives – Domestic Violence in Japan. In *The American psychologist*. 54 (1): 50-54
- Lindsey, Linda L.
1997 *Gender Roles: A Sociological Perspective*. NJ: Prentice Hall.
- Murakami, Masaru, Takeshi Fujibayashi, Kae Masumoto
1988 Sagaken no ippaniryokikan ni okeru arukorushou no jittaichousa ni tuite no houkoku [Report of fact finding inquiry on alcoholism at Saga prefecture's general medical institutions]. In *Ikai Saga*. (July): 33-35. [In Japanese]
- Marshall, Mac and Leslie B. Marshall
1990 *Silent Voices Speak: Women and Prohibition in Truk*. Belmont, CA: Wadsworth Publishing Company.
- Mascia-Lee, Frances, E.
2000 *Gender and Anthropology*. IL: Waveland Press.
- Maruyama Katsuya
2002 Arukōru kanren shikkan kanja e no kakuryouiki ni okeru torikumi (Various interventions for alcohol related disordered patients). In *Nihon Arukōru Kanrenmondai Gakkai Zasshi* (The Journal of the Japanese Society of Alcohol-Related Problems). Vol 4 (May): 111
- Mayfield, Demmie, Gail Mcleod and Patricia Hall
1974 The CAGE Questionnaire: Validation of a New Alcoholism Screening Instrument. In *Am J Psychiatry*. 131 (10): 1121-1123
- Mitamura, Akira, Ogata Motoi, Yoshiaki Okamoto, Hiroshi Sanada, Akira Yamamoto, Masatoshi Teraoka, Kunie Sato, Touhei Murayama and Hidenori Nakagawa
1978 Honpou ni okeru Michigan Alcoholism Screening Test (MAST) no Ouyou – Shiryo no toukeigakutekikentou wo chushin to shite [Application of Michigan Alcoholism Screening Test (MAST) to Alcoholics and Non-alcoholics in Japan – Chiefly statistical analyses of data]. In *Seishin-igaku*. 20 (10): 1079-1096. (In Japanese)
- Mitamura, Akira, Kenji Yambe, Yoshioki Okamoto and Motoi Ogata
1981 Honpou ni okeru Michigan Alcoholism Screening Test (MAST) no Kentou [Study on Michigan Alcoholism Screening Test (MAST) in Japan] . In *Seishin-igaku*. 23 (9): 903-911. (In Japanese)
- Nada, Inada
1981 *Arukōru-Chudoku* [Alcohol Addiction/ Alcoholism]. Tokyo: Kinokuniyashobo. [In Japanese]
- Nakamura, Keiko, Atsuko Tanaka, and Takehito Takano
1993 The Social Cost of Alcohol Abuse in Japan. In *Journal of Studies on Alcohol*. 54, 5 September: 618-625

- Nakane, Chie
1970 Japanese Society. CA: University of California Press
- Nagayama, Hisao and Hiroshi Kawashima
1988 Nihon no sui o tsutaeru kotowaza—Sake [Proverbs that convey Japaneseness—Sake].
Tokyo: Soutakusha.
- Nukata, Akira
1979 Tairyō-inshusha to mondai-inshusha no suitei [Epidemiological study of heavy drinkers
and problem drinkers]. In Arukoru-izon-sho [Alcohol Dependence Syndrome]. Saito, Satoru,
Tomoji Yanagida, Kazuo Shimada eds. Pp. 193-203. Tokyo: Yugaikikaku-sensho.
- Ochiai, Emiko
1997 The Japanese Family System in Transition: a sociological analysis of family change in
Japan. Tokyo: LTCB International Library Foundation.
- Omoto, Miyako
1994 Drinking Problems in the Workplace in Japan. In Asian Medical Journal. 37 (1): 35-46
- Ortner, Sherry
1974 “Is Female to Male as Nature to Culture?” In Women, Culture, & Society, edited by
Michelle Zimbalist Rosaldo and Louise Lamphere, pp. 67-88. Stanford, CA: Stanford
University Press.
- Pittman, D. J.
1967 International Overview: Social and Cultural Factors in Drinking Patterns, Pathological
and Nonpathological. In Pittman (ed.), Alcoholism. Pp. 3-20, NY: Harper & Row.
- Rosaldo, Michelle Zimbalist
1974 “Women, Culture, & Society: A Theoretical Overview.” In Woman, Culture, and
Society, edited by Michelle Zimbalist Rosaldo and Louise Lamphere, pp 17-42. Stanford,
CA: Stanford University Press.
- Rosaldo, Michelle Zimbalist, and Louise Lamphere, eds.
1974 Women, Culture, & Society. Stanford, CA: Stanford University Press.
- Saito, Satoru
1989 Kazokuizonsho [Family Crisis]. Tokyo: Seushinshobo
- Saito, Satoru
1995 Shiheki to shite no Shigoto [Work as Addiction]. Tokyo: Health Work Kyokai
- Saito, Satoru
1995 Shakai no naka no Otoko [Men in Society]. Tokyo: Health Work Kyokai
- Saito, Satoru

1996 Adult Children to Kazoku [Adult children and Family]. Tokyo: Gakuyoshobo [in Japanese].

Saito, Satoru

2003 Kouen—Shiheki to Gender [Invited Talk—Addiction and Gender]. In Japanese Journal of Addiction and Family. 20 (1):39-52.

Saito, Satoru, and Naoki Ikegami

1978 KAST (Kurihama Alcoholism Screening Test) and its Applications. In Journal of Study on Alcoholism. 13 (4): 229-237

Saitoh, Satoru, and Makoto Shimada

1990 Arukoru-izon-shō no shippei gainen [The concept of alcohol-dependence-syndrome]. Igaku no ayumi. 154 (13): 971-975.

Shakaibyourikenkyuuhan (Hiroaki Kouno, Hideaki Konno, Seiichirou Saitou, Satoru Saitou)

1977 Gendaishakai ni okeru inshukoudou ni kansuru kenkyuu [Research related to drinking behavior in contemporary society]. Tokyo: Yokokaihatsusentaa (In Japanese)

Schaef, Anne Wilson

1986 Co-Dependence: Misunderstood-Mistreated. Minnesota: Winston Press.

Schaef, Anne Wilson

1987 When Society Becomes an Addict. San Francisco: Harper & Row.

Shimada, Kazuo

1978 Nihonjin no Inshu Kōdō [Drinking Behaviors of Japanese People]. In Arukōru Izonshō (Alcohol Dependence Syndrome). Satoru Saito, Tomoji Yanagida, and Kazuo Shimada, eds. Pp.143-155. Tokyo: Yugaikikakusensho. (In Japanese)

Shima, Satoru, Kei Miyamoto, Ookawa Hideo, Naonori Hiro, Tsutomu Kudo, Masatomo Horie, Tsunoda Tooru and Satoshi Takagi

1991 Kigyōjyūgyōin ni okeru kankinuijō to inshu [Liver Dysfunction and Alcohol Intake in Employees]. In Arukōruirōkenkyū. 8 (2): 153-159

Shimizu, Shinji

1990 An alcoholic social system: Drinking culture and drinking behavior in Japan. In Journal of Mental Health. 36: 85-100

Liquor Tax and Industry Division, Taxation Department, National Tax Agency

2002 Suzeikazei Jokyo no Gaiyo [Alcoholic Beverages Tax Related Statistics]. Tokyo: Liquor Tax and Industry Division, Taxation Department, National Tax Agency.

Smith, Robert J.

19?? Gender Inequality in Contemporary Japan. In The Journal of Japanese studies. 13 (1): 1-25

Sorifu

2000 Josei ni taisuru bōryoku ni kansuru kihontekihōsaku ni tsuite no chūkantorimatome ni tsuite [An interim report – countermeasure to violence against women]. Electronic document. <http://www.sorufu.go.jp/danjyo/cyukan/h12/index.html>

Sourifu koho shitsu [The Prime Minister Office], ed.

1989 Nihonjin no sake to tobacco [Statistics for Japanese people's Sake and Tobacco habits]. Tokyo: Okurasho insatsu kyoku

Stone, Linda

2000 Kinship and Gender: An Introduction. Second Edition. Boulder, CO: Westview Press.

Stone, Linda and Caroline James

2005 "Dowry, Bride-Burning, and Female Power in India." In *Gender in Cross-Cultural Perspective*, edited by Caroline B. Brettell and Carolyn F. Sargent, pp 310-320. NJ: Pearson Education.

Stone, Linda and Nancy McKee

1998 *Gender and Culture in America*. NJ: Prentice Hall.

Sugimoto, Yoshio

1999 Making Sense of Nihonjinron. Thesis Eleven, Number 57: 81-96.

Takagi, Satoshi

1987 Naika de no mondaiinshu no atsukaikata [Treatment of problem drinkers in internal medicine]. In *Arukoru irou kenkyu*. 4 (4): 274-279. (In Japanese).

Takagi Satoshi, Toshikazu Takagi, Jun Satou, Akira Yokoyama, Akira Eboshida and Katsuya Maruyama

1989 Ippan naika gairai ni okeru mondaiinshusha no atsukaikata [Treatment for problem drinkers of out patients in internal medicine]. In *Current Therapy*. 7 (5): 690-694. (In Japanese)

Turner, James W.

1992 Ritual, Havitus, and Hierarchy in Fiji. In *Ethology*. 31 (4): 291-302

Woititz, Janet Geringer

1983 *Adult Children of Alcoholics*. Ponpano Beach, FL: Health Communications

Yoshihama, Meiko

1999 Sociology – Domestic Violence: Japan's 'Hidden Crime'. In *Japan quarterly*. 46 (3): 76-82

Zen Nihon Danshu Renmei [Japan Abstinence League]

2003 Koureisha no tame no shugai yobou kenkyu houkokusho [Research report on preventing elderly people's alcohol problems]. Tokyo: Zen Nihon Danshu Renmei. [In Japanese]

APPENDIX 1: KURIHAMA ALCOHOLISM SCREENING TEST

(SOURCE: Saito and Ikegami 1978)

	Answer	Score
1. Drinking impaired an important human relationship.	Yes	3.7
	No	-1.1
2. Impossible to keep the resolve of not drinking just for "this day."	Yes	3.2
	No	-1.1
3. Called as a drunkard.	Yes	2.3
	No	-0.8
4. Drunk oneself to insensibility.	Yes	2.2
	No	-0.7
5. Amnesia in the morning about the evening before.	Yes	2.1
	No	-0.7
6. Drinking from the morning on almost every day off.	Yes	1.7
	No	-0.4
7. To be absent or unable to keep important appointment due to a hangover.	Yes	1.5
	No	-0.5
8. To be diagnosed and treated for diabetes, liver or heart trouble.	Yes	1.2
	No	-0.2
9. When out of alcohol, experienced sweating, hand tremor, frustration of insomnia.	Yes	0.8
	No	-0.2
10. Drinking is necessary for the occupation.	Often	0.7
	Sometimes	0.0
	Seldom	-0.2
11. Unable to go to sleep without drinking.	Yes	0.7
	No	-0.1
12. Drinking over 3 <i>go</i> of <i>Sake</i> during evening dinner.	Yes	0.6
	No	-0.1
13. Arrested or protected [<i>sic</i>] for drinking by the police.	Yes	0.5
	No	-0.0
14. Getting angry when drunk.	Yes	0.1
	No	0.0

APPENDIX 2: QUESTIONNAIRE

1. Personal Character through Life History	
Topics	Example Questions
Family Structure (Before and After Marriage)	Where is your hometown?
	How many members are in your family? Who are they? (Are there any alcoholics, oppressive, workaholic, violent person in your family?)
	Tell me about your family members, their age, gender, occupation, hobby etc.?
	Healthy wife and mother-in-law relationship?
	How did your family make a living?
Childhood and Adolescence Memories	How do you describe yourself at that time? (E.g. Leadership type, popular, smart etc.)
	Is there any experience (e.g. encounter with a person, social event, accident) that significantly influenced your life?
	What was your dream?
Educational History	What is your final degree?
Occupation	What was/is your occupation? What did/do you do?
Marriage experience	How did you meet your husband (e.g. arranged, not arranged)?
	What did you expect in married life before the wedding? How is it in reality?
Others	Are there any important incidents or events that significantly influenced your life?

2. Feelings about Husband's Drinking (Question 1-14 are the modified version of Kurihama Alcoholism Screening Test questions.)	
1	Has your husband experienced any difficulties in personal relationships (i.e., with family or friends) because of his drinking?
	Original Drinking impaired an important human relationship.
2	Has your husband resolved to stop drinking for just one day but failed and had a drink?
	Original Impossible to keep the resolve of not drinking just for "this day."
3	Has your husband been accused of having a drinking problem by family (including you), friends, or coworkers?
	Original Called a drunkard.

4	Has your husband resolved to limit his drinking to a moderate amount, however he gave in and drank too much?	Original	Drunk oneself to insensibility.
5	Does your husband often wake up the next morning after drinking too much and is unable to recall everything that he did the night before?	Original	Amnesia in the morning about the evening before.
6	Does your husband generally begin drinking in the morning on his day off?	Original	Drinking from the morning on almost every day off.
7	Has your husband failed to keep an important promise or missed work because of a hangover?	Original	To be absent or unable to keep important appointment due to a hangover.
8	Has your husband been diagnosed as having or being treated for any of the following diseases: diabetes, liver disease or heart disease?	Original	To be diagnosed and treated for diabetes, liver or heart trouble.
9	When not under the influence of alcohol, has your husband suffered from any ailments such as sweating, shaky hands, irritability or insomnia?	Original	When out of alcohol, experienced sweating, hand tremor frustration of insomnia.
10	How often does your husband's work or business require him to drink?	Original	Drinking is necessary for the occupation.
11	Does your husband find it difficult to go to sleep without a drink?	Original	Unable to go to sleep without drinking.
12	Does your husband drink more than 3 <i>gou</i> of <i>Sake</i> nearly everyday?	Original	Drinking over 3 <i>gou</i> of <i>Sake</i> during evening dinner.
13	Has your husband been arrested as a consequence of something he did under the influence of alcohol?	Original	Arrested or protected [<i>sic</i>] for drinking by the police.
14	Does your spouse normally become short tempered when drunk?	Original	Getting angry when drunk.
15	Do you think your husband is a normal drinker?		
16	How do you view your husband's drinking at the beginning of your married life? Has your perspective changed over time?		

17	What do you think is the factor that leads your husband to drink a lot?
18	Are there any problems? (e.g. husband shouts, says violent things, summons, physically abuses, threatens, cries, destroys objects, causes trouble to others, puts himself in danger, has affair, abuses financially, or you are scared of him, put down by him, apologize for your husband to others, etc.)

3. Means of Improvement	
What was your desire at the time of the problem (e.g. anything: abandon the family, divorce, suicide, have more money, husband leave the house)?	
What did you actually do to solve the problem	
Did you seek help from others, such as your parents, relatives, friends or public services such as hospital, hospitals, religious organization, self-help groups? If yes, who were they? What was their response? Were they helpful?	
Did you or your husband go to the doctor? Was it helpful?	
Did you think about divorcing your husband? If yes, did you feel any resistance against it? If yes, why?	
What kind of service would you wish to have on a national policy or medical level in order to make your life easier at the time of the problem?	

APPENDIX 3: DYSFUNCTIONAL OF FUNCTIONAL DRINKING (MATRIX)

	Cultural Factors that Contribute to Wives Tolerating												Cultural Factors that Contribute to Men's Excessive Drinking								Alcoholic Family				Support	Other							
	Drinking Culture							Kinship & Gender Related Culture					Drinking Culture				Kinship & Gender Related Culture																
	A1	A2	A3	A4	A5	A6	A7	B1	B2	B3	B4	B5	B6	C1	C2	C3	C4	C5	C6	C7	D1	D2	D3	D4	D5	D6	D7	D8	E1	E2	E3	E4	F1
1	X	X			X	X	X	X	X	X	X	X	X	X	X			X	X	X		X		X			X	X	X	X	X		
2	X	X		X	X	X	X			X	X	X		X	X	X	X			X								X	X	X	X	X	X
3	X	X			X	X	X	X	X			X		X	X	X		X		X		X	X	X			X	X		X	X		
4	X	X	X	X	X					X			X	X	X	X			X	X		X		X		X		X		X	X		
5	X	X			X	X	X			X			X	X			X	X	X			X						X			X	X	
6	X	X			X	X	X	X		X	X	X	X	X	X			X	X	X		X	X	X		X		X	X	X	X		
7	X				X	X	X	X		X	X	X	X	X			X	X	X			X								X	X	X	X
8	X	X		X	X	X	X	X		X	X			X	X	X	X		X									X			X		
9	X				X	X	X	X		X	X	X	X	X			X	X	X							X	X	X		X	X		
10	X	X			X	X	X		X	X	X	X	X	X			X	X	X												X		
11	X	X			X	X	X		X	X		X	X	X	X			X	X	X		X	X				X		X	X	X		
12	X	X		X	X	X	X	X	X	X		X		X	X	X	X					X		X				X		X	X	X	
13	X	X	X	X	X	X	X			X		X	X	X	X	X			X	X		X				X	X	X	X	X	X		
14	X	X			X	X	X	X	X	X		X	X			X	X	X			X	X		X			X	X		X	X		
15	X	X			X	X	X		X	X		X	X	X	X	X					X		X			X	X	X	X	X	X		

	Cultural Factors that Contribute to Wives Tolerating											Cultural Factors that Contribute to Men's Excessive Drinking											Alcoholic Family				Support	Other						
	Drinking Culture							Kinship & Gender Related Culture				Drinking Culture							Kinship & Gender Related Culture															
	A1	A2	A3	A4	A5	A6	A7	B1	B2	B3	B4	B5	B6	C1	C2	C3	C4	C5	C6	C7	D1	D2	D3	D4	D5	D6	D7	D8	E1	E2	E3	E4	F1	E1
16	X	X		X	X	X	X			X	X	X		X	X		X	X	X	X			X	X	X	X		X		X	X			
17	X				X	X	X			X		X	X	X				X	X	X						X			X		X	X	X	
18	X	X		X	X	X	X		X	X				X	X		X	X	X	X								X	X		X	X		
19	X	X		X	X	X	X	X		X				X	X	X	X	X	X	X				X	X	X	X		X			X		
20	X	X		X	X	X	X	X	X	X	X		X	X	X		X	X	X	X			X		X			X	X		X	X		
21	X	X				X	X	X	X	X	X	X		X	X				X	X								X			X	X		
22	X	X			X	X	X		X	X			X	X	X			X	X	X		X		X			X		X		X	X	X	
23	X	X	X	X	X	X	X		X				X	X	X	X	X	X	X	X			X					X				X		
24																																		
25	X	X			X	X	X		X	X	X	X	X	X	X				X	X	X			X			X	X	X		X	X		
26	X	X			X	X	X			X				X	X			X	X	X			X		X				X		X	X		
27	X	X		X	X	X	X			X		X	X	X	X			X	X	X	X			X		X				X	X	X	X	
28	X	X		X	X	X	X			X		X		X	X		X	X	X	X	X	X		X			X			X	X			
29	X	X		X	X	X	X			X		X		X	X		X	X	X	X					X		X			X	X	X	X	
30	X	X			X	X	X			X				X	X			X	X	X			X		X			X			X	X		

APPENDIX 4

	A1	A2	A3	A4	A5	A6	A7	B1	B2	B3	B4	B5	B6
A1	1.00	0.47	0.05	0.16	0.69	0.69	0.69	0.14	0.15	0.69	0.15	0.24	0.17
A2	0.47	1.00	0.10	0.34	0.29	0.29	0.29	-0.11	0.32	0.29	-0.08	-0.09	-0.22
A3	0.05	0.10	1.00	0.31	0.07	-0.46	-0.46	-0.20	-0.22	0.07	-0.22	-0.07	0.02
A4	0.16	0.34	0.31	1.00	0.23	-0.04	-0.04	-0.11	-0.16	-0.04	-0.16	-0.17	-0.28
A5	0.69	0.29	0.07	0.23	1.00	0.46	0.46	-0.07	-0.05	0.46	-0.05	0.07	0.25
A6	0.69	0.29	-0.46	-0.04	0.46	1.00	1.00	0.20	0.22	0.46	0.22	0.35	-0.02
A7	0.69	0.29	-0.46	-0.04	0.46	1.00	1.00	0.20	0.22	0.46	0.22	0.35	-0.02
B1	0.14	-0.11	-0.20	-0.11	-0.07	0.20	0.20	1.00	0.08	0.20	0.51	0.15	-0.02
B2	0.15	0.32	-0.22	-0.16	-0.05	0.22	0.22	0.08	1.00	-0.05	0.03	0.06	0.33
B3	0.69	0.29	0.07	-0.04	0.46	0.46	0.46	0.20	-0.05	1.00	0.22	0.35	-0.02
B4	0.15	-0.08	-0.22	-0.16	-0.05	0.22	0.22	0.51	0.03	0.22	1.00	0.34	0.19
B5	0.24	-0.09	-0.07	-0.17	0.07	0.35	0.35	0.15	0.06	0.35	0.34	1.00	0.16
B6	0.17	-0.22	0.02	-0.28	0.25	-0.02	-0.02	-0.02	0.33	-0.02	0.19	0.16	1.00
C1	1.00	0.47	0.05	0.16	0.69	0.69	0.69	0.14	0.15	0.69	0.15	0.24	0.17
C2	0.42	0.88	0.12	0.39	0.24	0.24	0.24	-0.03	0.18	0.24	-0.18	-0.15	-0.30
C3	0.05	0.10	0.46	0.31	0.07	0.07	0.07	0.07	-0.22	0.07	-0.22	-0.07	-0.25
C4	0.17	0.37	0.29	0.93	0.25	-0.02	-0.02	-0.02	-0.22	-0.02	-0.08	-0.12	-0.34
C5	0.69	0.29	0.07	0.23	1.00	0.46	0.46	-0.07	-0.05	0.46	-0.05	0.07	0.25
C6	1.00	0.47	0.05	0.16	0.69	0.69	0.69	0.14	0.15	0.69	0.15	0.24	0.17
C7	1.00	0.47	0.05	0.16	0.69	0.69	0.69	0.14	0.15	0.69	0.15	0.24	0.17
D1	0.06	0.13	-0.09	-0.07	0.09	0.09	0.09	-0.02	-0.05	0.09	0.18	0.25	-0.09
D2	0.07	0.15	-0.10	-0.15	0.10	0.10	0.10	0.11	0.28	0.10	0.08	-0.11	0.22
D3	0.21	0.25	0.23	0.09	0.31	0.04	0.04	-0.17	-0.11	0.04	0.03	0.03	0.01
D4	0.08	0.18	0.60	0.15	0.12	-0.24	-0.24	0.03	-0.18	0.12	0.00	0.15	-0.06
D5	0.15	0.32	-0.22	0.11	0.22	0.22	0.22	-0.06	0.03	0.22	-0.25	0.20	0.05
D6	0.15	0.32	0.33	0.25	0.22	-0.05	-0.05	-0.06	-0.25	0.22	-0.25	-0.08	-0.08
D7	0.09	-0.05	-0.13	0.07	0.13	0.13	0.13	0.14	0.10	0.13	-0.24	0.21	0.03
D8	0.09	-0.05	0.20	-0.10	0.13	-0.20	-0.20	0.14	-0.07	0.13	0.10	-0.14	0.37
E1	0.20	0.22	0.25	0.14	0.02	0.02	0.02	-0.12	0.08	0.02	-0.05	-0.02	-0.20
E2	0.26	0.14	0.19	0.05	0.38	0.09	0.09	0.24	0.14	0.38	0.14	0.05	0.09
E3	0.08	-0.09	-0.12	-0.03	0.12	0.12	0.12	0.22	-0.37	0.12	0.37	0.34	0.12
E4	0.42	0.09	0.12	-0.15	0.24	0.24	0.24	-0.03	0.00	0.60	0.00	0.40	0.06
F1	u/d*	u/d*	u/d*	u/d*	u/d*	u/d*	u/d*	u/d*	u/d*	u/d*	u/d*	u/d*	u/d*
G1	0.11	-0.21	-0.16	0.08	0.16	0.16	0.16	0.01	-0.18	0.16	-0.03	0.30	0.04

	C1	C2	C3	C4	C5	C6	C7	D1	D2	D3	D4	D5	D6	D7	D8
C1	1.00	0.42	0.05	0.17	0.69	1.00	1.00	0.06	0.07	0.21	0.08	0.15	0.15	0.09	0.09
C2	0.42	1.00	0.12	0.42	0.24	0.42	0.42	-0.15	0.18	0.33	0.20	0.37	0.37	0.00	0.00
C3	0.05	0.12	1.00	0.29	0.07	0.05	0.05	-0.09	-0.10	-0.04	0.24	0.05	0.33	0.20	0.20
C4	0.17	0.42	0.29	1.00	0.25	0.17	0.17	0.13	-0.17	0.14	0.12	0.05	0.19	0.03	-0.13
C5	0.69	0.24	0.07	0.25	1.00	0.69	0.69	0.09	0.10	0.31	0.12	0.22	0.22	0.13	0.13
C6	1.00	0.42	0.05	0.17	0.69	1.00	1.00	0.06	0.07	0.21	0.08	0.15	0.15	0.09	0.09
C7	1.00	0.42	0.05	0.17	0.69	1.00	1.00	0.06	0.07	0.21	0.08	0.15	0.15	0.09	0.09
D1	0.06	-0.15	-0.09	0.13	0.09	0.06	0.06	1.00	-0.13	0.07	-0.15	-0.05	-0.05	-0.17	-0.17
D2	0.07	0.18	-0.10	-0.17	0.10	0.07	0.07	-0.13	1.00	-0.05	-0.18	0.28	-0.12	0.05	0.05
D3	0.21	0.33	-0.04	0.14	0.31	0.21	0.21	0.07	-0.05	1.00	0.21	-0.11	0.44	-0.40	-0.24
D4	0.08	0.20	0.24	0.12	0.12	0.08	0.08	-0.15	-0.18	0.21	1.00	0.00	0.55	-0.22	0.22
D5	0.15	0.37	0.05	0.05	0.22	0.15	0.15	-0.05	0.28	-0.11	0.00	1.00	0.31	0.44	0.10
D6	0.15	0.37	0.33	0.19	0.22	0.15	0.15	-0.05	-0.12	0.44	0.55	0.31	1.00	-0.24	0.10
D7	0.09	0.00	0.20	0.03	0.13	0.09	0.09	-0.17	0.05	-0.40	-0.22	0.44	-0.24	1.00	-0.04
D8	0.09	0.00	0.20	-0.13	0.13	0.09	0.09	-0.17	0.05	-0.24	0.22	0.10	0.10	-0.04	1.00
E1	0.20	0.30	-0.02	0.21	0.02	0.20	0.20	0.09	-0.42	0.26	0.06	-0.33	-0.05	-0.20	-0.03
E2	0.26	0.25	0.19	0.09	0.38	0.26	0.26	-0.24	0.28	-0.05	0.32	0.00	0.14	0.18	0.35
E3	0.08	-0.04	-0.12	0.12	0.12	0.08	0.08	0.15	-0.18	0.21	0.04	0.00	0.00	-0.22	0.00
E4	0.42	0.28	-0.24	-0.12	0.24	0.42	0.42	-0.15	-0.09	0.33	0.20	0.18	0.18	0.00	0.00
F1	u/d*	u/d*	u/d*	u/d*	u/d*	u/d*	u/d*	u/d*	u/d*	u/d*	u/d*	u/d*	u/d*	u/d*	u/d*
G1	0.11	-0.13	-0.16	0.19	0.16	0.11	0.11	0.05	-0.01	-0.08	-0.27	0.12	-0.34	0.26	-0.11

	E1	E2	E3	E4	F1	G1
E1	1.00	-0.09	-0.12	0.30	u/d*	-0.19
E2	-0.09	1.00	-0.06	0.25	u/d*	-0.05
E3	-0.12	-0.06	1.00	0.20	u/d*	0.54
E4	0.30	0.25	0.20	1.00	u/d*	0.27
F1	u/d*	u/d*	u/d*	u/d*	u/d*	u/d*
G1	-0.19	-0.05	0.54	0.27	u/d*	1.00

(*) The correlation involving F1 is mathematically undefined since there is no variation in the data of F1.

GLOSSARY

Adult Children [AC]: Short for “Adult Children of Alcoholics” [ACoA]. AC is a grass-root concept that emerged among American case-workers and therapists who observed the common traits of the children of alcoholics who tend to behave sacrificially to the level of self destruction. While there are children of alcoholics who themselves become alcoholics, spouses of alcoholics, or deviants who constantly break the social norms, the majority of the children of alcoholics are quiet and unnoticeable in the society, as Cork (1969) called them *Forgotten Children* in the book of the same title. The expression “Adult Children” became popular in the U.S. upon the publication of two books: *It Will Never Happen To Me!* by Claudia Black in 1981 and *Adult Children of Alcoholics* by Janet Woititz in 1983. In Japan, the concept was introduced by Satoru Saito and became popular in the 1990s. Saito does not regard adult children to be only the children of alcoholics but rather people who possess the same traits as the children of alcoholics due to their dysfunctional family background. Saito describes adult children as follows: (1) adult children are people who grew up in a family that does not provide peace to the person; (2) adult children “behave as others expect them to behave,” “cannot say ‘no,’” “cannot distinguish ‘clinging to a person’ from love,” “cannot enjoy genuinely,” “pretend,” “are addicted to self-punishment.” Saito also states that the concept of adult children (3) is neither a medical term for diagnosis nor a label to stigmatize others but is an awareness people who seek to understand the reasons for their painful life attain (Saito 1996: 83). [See also “co-dependence” below]]

Amae (noun): Passive objective love. The feeling of seeking other people’s care, often without taking any direct action. The psychological mechanism of *amae* was theorized by Takeo Doi in his classic book *Amae no kozo* [The anatomy of dependency] in 1973.

Banshaku: Drinking with the evening meal, usually at home after work. This drinking pattern is considered to be the most common way men drink in Japan. There is a ‘belief’ that drinking in *banshaku* is part of the Japanese drinking culture, a culture which functions to keep men sane by drinking and releasing the stress of their harsh work life. [See also 101 banshaku on page 489.]

Business bachelor: A man who takes up a post without his family. He is in the situation of *tanshinfunin*.

Co-dependence: Co-dependence is a grass-root concept emerged among the case-workers and therapist who were engaged in alcohol treatment. Co-dependent people are those who have been affected by a chronological neurotic person or by a person who was afflicted by chemical dependency. The term “co-dependent” is often used to address the spouse of an alcoholic or children who grew up in an alcoholic family. Some scholars, such as Sharon Wegsheider-Cruse define all persons who have one or more alcoholic parents or

grandparents, or grew up in an emotionally repressive family as suffering from co-dependence (Schaef 1986). According to Wegsneider-Cruse's definition, co-dependence does not allow space for those who grew up in an alcoholic or dysfunctional family but do not have co-dependence traits. I therefore follow Saito's definition of co-dependence where he describes co-dependence as certain traits derived from the person's dysfunctional family background (e.g. live altruistically to the extent of harming oneself). Saito explains that the essence of co-dependence is "the person's lack of self-respect" which is rooted in the person's dysfunctional family background. And this is the cause of the characteristic behaviors of co-dependence—the feeling that one "must be needed by others." And this feeling is what drives the co-dependent person's characteristic traits: take care of chemical dependant person's problems intensively; tolerate in a battered situation with the feeling "I am the only one who could understand him"; unconsciously denying ones feelings (numb to one's feelings); cannot tolerate the situation where the addicted husband recovers from his dependency problem and therefore do not require the co-dependant person's help anymore, etc. In other words, co-dependent persons are those who depend on "the dependency problem." It is because of this root that co-dependent persons end up having relationships with problematic persons such as alcoholics or chemically dependant persons, because they are the one with whom the co-dependent person feels most comfortable. By recognizing one's problem and learning to confront one's feelings and behave accordingly, it is possible to recover from co-dependence. In other words, although children of alcoholics have a tendency of marrying alcoholics, it is not a predetermined destiny.

Danshukai: Japanese self-help group for alcoholics. (Different from the American "Alcoholics Anonymous [AA]") Family members of alcoholics are also encouraged to participate. Anonymity is not as strict as in AA.

Domestic Violence Screening Test: A screening test to detect the presence of domestic violence.

Donzoko: [The very bottom of life] It is believed that after alcoholics or their family reach this stage of life, it often goes better afterwards. This is because when they reach this stage they tend to humbly accept the seriousness of their problem without further denial (the obstacle for the alcoholic's recovery) and therefore are willing to accept the specialist's advice and change their lives accordingly. Some professionals for alcohol treatment therefore say that the treatment should enter at this moment and therefore wives should not help or support the alcoholics which otherwise prolongs the time until reaching this stage.

Enabler: A person, often the wife of the alcoholic, who subtly help and support the alcoholic's drinking.

Hikikomori (noun): Situation of shutting oneself in for a long period of time. The problem of *hikikomori* is serious in Japan, but reliable information on the population of *hikikomori* (adjective of *hikikomori*) people is not available. Saito states that Hikikomori (2003) is a male dominated phenomenon where it happens 4-5 times more to male than to female).

Honne: ↔ *tatemae* “Real intention” near to “true behavior”. Behavior which stems from ones real intention. Ego-centered behavior.

Talk in honne: talk openly

KAST: Abbreviation for Kurihama Alcoholism Screening Test. Used in the Japanese clinical setting to detect people who have a strong potential for having alcoholism. A study showed that KAST can discriminate the alcoholic group from the normal with an accuracy of 98.5%. (Saito and Ikegami 1978)

Kateinai-rikon: [Divorce within the household.] A couple that is legally married but has no intimate relationship. The problem of *kateinai-rikoni* is serious in Japan, but reliable information on the number of *kateinai-rikon* couples in Japan is not available.

Kyukanbi: [A resting day for the liver.] There is a word play involved here: *kyukanbi* originally means “the resting day for the newspaper delivery [The day without newspaper delivery].” Alternating the middle Chinese character of the resting day for the newspaper delivery [*Kyu-kan-bi*] from “*kan* (publish)” to “*kan* (liver),” the meaning changes while maintaining the pronunciation.

Mama: Female manager of *mizu-shobai* [water-business]: bar, hostess bar, sex industry, etc. More information on Mama in the context of hostess bars, see Anne Allison 1994.

Samishigariya: A person who cannot stand being alone.

Settai: Business related reception. Reception with customers.

Shizuka na aruchu: [Quiet alcoholic] A term used by Inada Nada (1981) in the classic book *Arukoruchudoku* [alcohol addiction]. In this book, Nada describes the characteristics of modern Japanese alcoholics who tend to be free from alcohol related sociological problems (e.g. quarrels, traffic accidents, lack of money, unemployment) but are alcohol dependent. This study contests the validity of his assumption that the modern Japanese alcoholics are problem free quiet alcoholic.

Tatemae: ↔ *honne* Superficial behavior (≈ fake behavior). Behavior that adjusts to other peoples’ expectations by concealing the actor’s real intention (*honne*).

Tanshinfunin (noun/verb): Business bachelor. Take up a post without his family.

Types of Alcoholic Drinks Referred to in the Study

	Ingredient <i>Name of the product</i>	Alcohol % Price
Beer:	Fermented malted grain, flavored with hops, etc.	4.0-6.0%
Sake	Fermented rice <i>One-cup</i>	15.5-16.5%
Wine	Fermented juice of grapes	13.0%
Whiskey	Distilled from fermented malted grain <i>Daruma</i>	39.0-43%
Shochu	Distilled from fermented sweet potato, rice, buckwheat etc. <i>Daigoro</i>	25.0%

Unites used in the study

1 gou = 0.18 liter = 0.48 U.S. gallon

1 sho = 1.80 ml = 0.48 U.S. gallon

US\$ 1 = JPY 110